

Job Name: 26-1319 822587 Caldwell Energy Building  
 Job Location: Shelbyville, KY  
 Contractor: Contech Engineering Solutions

Plant: Beaver Dam  
 2/12/2026 1:04:36 PM

Tech: S. Felletter  
 PC: T. Sekula



**Structure ID: 10-CS-3**

**P2 MH036RS42**

**MH RISER T/G**

- P4) 24" - CASTING HEIGHT - 0"
- P3) 36" - MH FLAT TOP SPECIAL (FRAME CAST IN) F/G - 10"
- P2) 36" - MH RISER T/G - 42"
- P1) 36" - MH BASE T/n - 12"
- 1) CVSTENCILING
- 1) ASSEMBLY REQUIRED
- 1) This Structure Includes a Cast-in Item
- 2) 36" - Conseal CS-102 1.00"
- 2) Hole - 16

0 lb  
 896 lb  
 1628 lb  
 1272 lb  
 0 lb  
 0 lb  
 0 lb  
 0 lb  
 0 lb  
 0 lb  
 -----  
 Structure Total: 3796 lb

**Structure Notes:**  
 CASTING FRAME TO BE CAST INTO TOP SLAB  
 LIFTING ANCHORS TO BE INSTALLED ON THE OUTSIDE OF THE STRUCTURE  
 ICAST TO INSTALL THE INTERNALS  
 CONTECH'S LOGO AS WELL AS THE INLET AND OUTLET MUST BE STENCILED ONTO THE STRUCTURE

Rim: 706.6' Rim to Invert: 2.12' Slack: -0.52' Sump: 38.04" Step Position:

Position	Elev	Angle	Ext. (cw)	Pipe	Pipe OD	Connector	Hole	Horz Size	Up ( )	Offset
Invert 1	704.48'	270°	103.673"	12" HDPE	14.5"	Hole 16	16"	16.58"	20.54"	0"
Invert 2	704.48'	344°	138.164"	12" HDPE	14.5"	Hole 16	16"	18.044"	20.54"	6"
Invert 3										
Invert 4										
Invert 5										
Invert 6										
Invert 7										
Invert 8										

**RIGHT-SIDE UP VIEW (int. dimensions)**

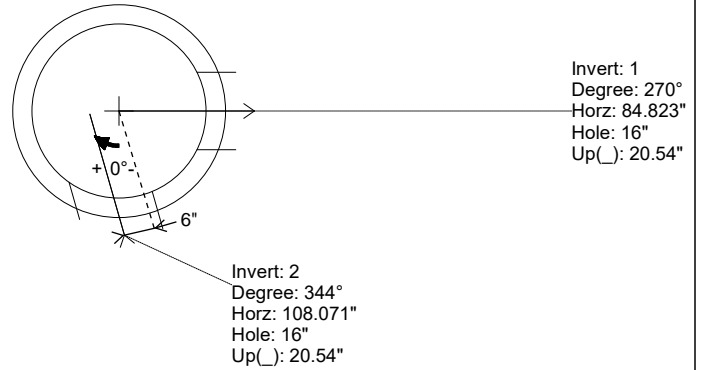
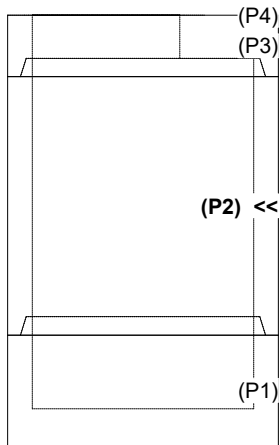

**INSIDE WALL DIMENSIONS**

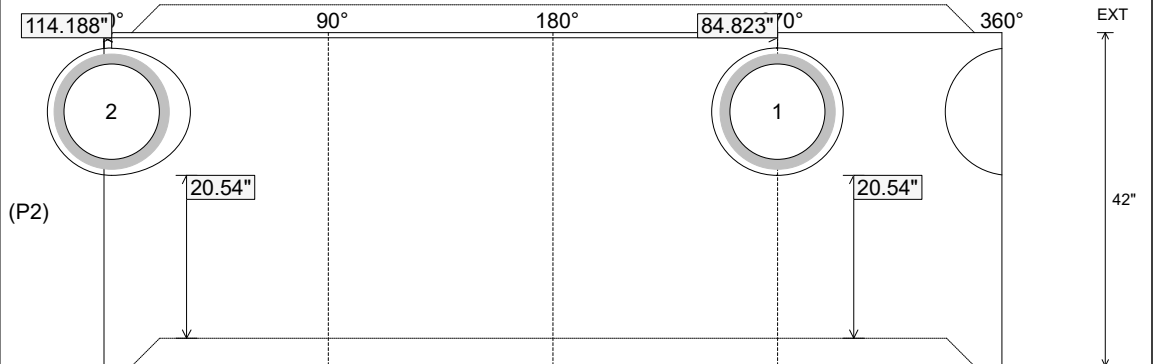

Coating (Int): Coating (Ext):	Seam Up: Tongue Seam Dn: Groove	Wall Thickness: 4" Floor Height: 0"	Height (Int): 42" Height (Ext): 42"	Weight (Net): 1628 lb Volume (Net): 0.42cu.yd
----------------------------------	------------------------------------	--	--	--