

Job Name: 26-1318 - Red River Ridge
 Job Location: Clarksville, TN 37040
 Contractor: Byard Construction, LLC

Plant: 100
 4/13/2026 1:40:31 PM

Tech: Jared - F
 PC: A. Chambers

Structure ID: F4-5 ST-CI

P2 MH048LD12-24X36RECT

MH FLAT TOP w/24"x36" Hole F/G

- P3) 24" x 36" - CASTING HEIGHT - 6.5"
- P2) 48" - MH FLAT TOP w/24"x36" Hole F/G - 12"
- P1) 48" - MH BASE Custom Ht T/n - 35"
- 1) CASTING - JBS 3080 SET (F/G/H)
- 1) 48" - Conseal CS-102 1.00"
- 1) 24" x 36" - Conseal CS-102 1.00"
- 1) Hole - 18

0 lb
 1300 lb
 3666 lb
 500 lb
 0 lb
 0 lb
 0 lb

 Structure Total: 5466 lb

Structure Notes:
 1. PER ASTM C478 SPECIFICATIONS.
 2. CONCRETE = 4,000 PSI AT 28 DAYS.
 3. NO STEPS AND NO INVERT CHANNEL.
 4. CASTING BY ICAST (JBS 3080 SINGLE SET (F/G/H)).

REINFORCING PER ASTM A615 (GRADE 60).
 - TOP SLAB (As .62) #5 BARS AT 6" C.C.E.W..
 - RISER/WALLS (As .12)
 - FLOOR (As .31) #5 BARS AT 12" C.C.E.W.

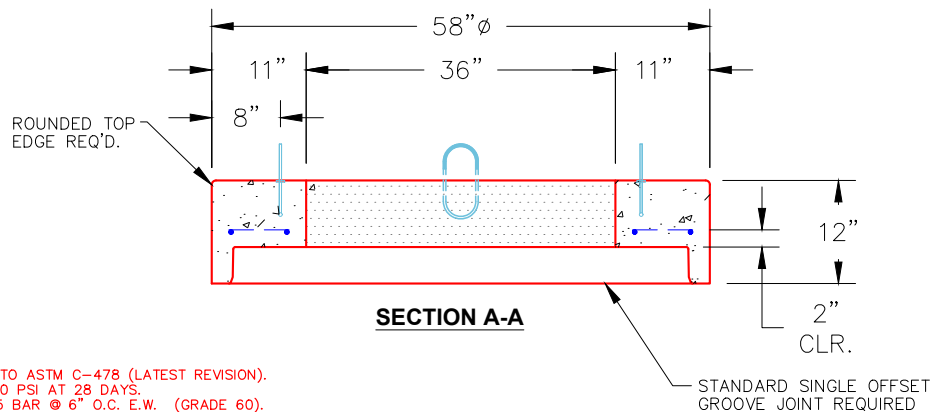
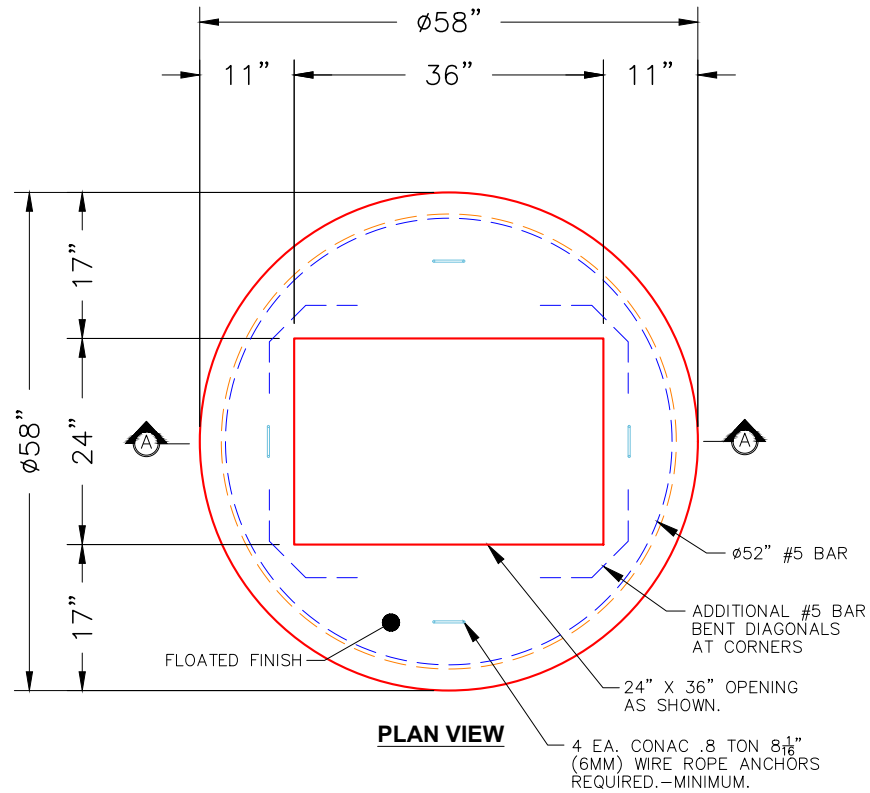

NOTES:

- 1. MANUFACTURED TO ASTM C-478 (LATEST REVISION).
- 2. CONCRETE: 4,000 PSI AT 28 DAYS.
- 3. REINFORCING: #5 BAR @ 6" O.C. E.W. (GRADE 60).

Coating (Int):
 Coating (Ext):

Seam Up: Flat
 Seam Dn: Groove

Wall Thickness: 5"

Height (Ext): 12"

Weight (Net): 1300 lb
 Volume (Net): 0.46cu.yd