

Job Name: 26-1315 - Ruby Drive Extension  
 Job Location: Madisonville, KY  
 Contractor: Steve Pleasant Excavating

Plant: 100  
 3/31/2026 10:53:17 AM

Tech: J. Horsley  
 PC: E. Bradley



**Structure ID: E-13 SS-MH**

**P2 MH048CN36**

**ECC CONE w/ 24" HOLE F/G**

- P3) 24" - CASTING HEIGHT - 7"
- P2) 48" - ECC CONE w/ 24" HOLE F/G - 36"
- P1) 48" - MH BASE T/n - 24"
- 1) 48" - MH INVERT CHANNEL - FULL HEIGHT
- 1) JOINT WRAP - 0.065"x6"x50" CONSEAL CS212
- 1) JOINT WRAP PRIMER - CONSEAL CS-75 (1 gal.)
- 1) Inflow Dish FOR MC-315
- 1) CASTING - HOE MC-315 Self Seal F/C Sanitary
- 1) 48" - Conseal CS-102 1.00" (Double)
- 1) PSX - 12-08 NYLO
- 4) MH Step ML-10-TDS-NCR - 10"

0 lb  
 3000 lb  
 2959 lb  
 1440 lb  
 0 lb  
 0 lb  
 2 lb  
 258 lb  
 0 lb  
 8 lb  
 0 lb

- Structure Notes:
1. PER ASTM C-478 SPECS
  2. CONCRETE: 4,000 PSI AT 28 DAYS
  3. REINFORCEMENT: PER ASTM A615
  5. STEPS REQUIRED
  6. HOE MC-315 FRAME & COVER "SANITARY" SUPPLIED BY ICAST
  7. HOE MC-315 INFLOW DISH SUPPLIED BY ICAST

Structure Total: 7667 lb

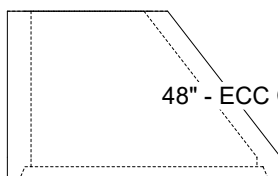
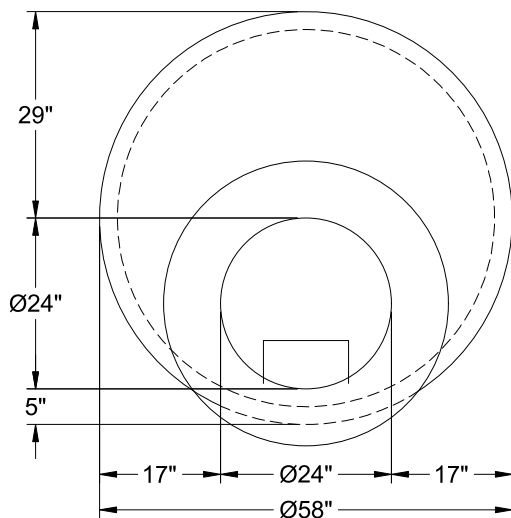

48" - ECC CONE w/ 24" HOLE F/G - 36" - (P2)

Coating (Int):  
 Coating (Ext):

Seam Up: Flat  
 Seam Dn: Groove

Wall Thickness: 5"

Height (Ext): 36"

Weight (Net): 3000 lb  
 Volume (Net): 0.5cu.yd