

| | | | |
|--|----------------------|------------------|--|
| Job Name: 26-1315 - Ruby Drive Extension | Plant: 100 | Tech: J. Horsley |  |
| Job Location: Madisonville, KY | 3/31/2026 9:20:25 AM | PC: E. Bradley | |
| Contractor: Steve Pleasant Excavating | | | |

Structure ID: D-4 CBIA

P1 BX2436-08BVF

BOX BASE 8inW, 8inF, Variable Ht T/n

| | |
|---|-----------------|
| P3) 24" x 120" - CB INLET KY A 10' TOP LEFT F/G - 10" | 3400 lb |
| P2) 24" x 120" - CB INLET KY A 10' BOTTOM LEFT T/G - 18" | 5270 lb |
| P1) 24" x 36" - BOX BASE 8inW, 8inF, Variable Ht T/n - 21" | 3194 lb |
| 1) CASTING - HOE KY-206 F/C (KY CBI A) | 206 lb |
| 1) This Structure Includes a Cast-in Item - KY-206 Frame Flange Side Up | 0 lb |
| 1) 24" x 36" - Conseal CS-102 1.00" | 0 lb |
| 1) DOGHOUSE INVRTD - 24"x24" | 0 lb |
| Structure Total: | 12069 lb |

- Structure Notes:**
1. PER KYTC CBI TYPE A / ASTM C-913 SPECS
 2. CONCRETE: 4,000 PSI AT 28 DAYS
 3. REINFORCEMENT: #5 BAR @ 12" C.C. E.W. (GRADE 60) - 2" MIN. REBAR CLEARANCE (TYP)
 4. NO STORM INVERT
 5. NO STEPS
 6. HOE KY-206 FRAME & COVER "STORM" SUPPLIED BY ICAST - FRAME TO BE CAST INTO TOP PHASE TOP FLANGE SIDE UP

Rim: 454.07' Rim to Invert: 4.09' Slack: 0.08" Sump: 0" Step Position:

| Position | Elev | Angle | Ext. (cw) | Pipe | Pipe OD | Connector | Hole | Horz Size | Up () | Offset |
|----------|---------|-------|-----------|----------|---------|-------------------------|-----------|-----------|--------|--------|
| Invert 1 | 449.98' | 90° | 26" | 18" HDPE | 21.2" | DOGHOUSE INVRTD 24"x24" | 24" x 24" | 24" | -3" | 0" |
| Invert 2 | | | | | | | | | | |
| Invert 3 | | | | | | | | | | |
| Invert 4 | | | | | | | | | | |
| Invert 5 | | | | | | | | | | |
| Invert 6 | | | | | | | | | | |
| Invert 7 | | | | | | | | | | |
| Invert 8 | | | | | | | | | | |

RIGHT-SIDE UP VIEW (int. dimensions)

UPSIDE-DOWN VIEW (int. dimenions)

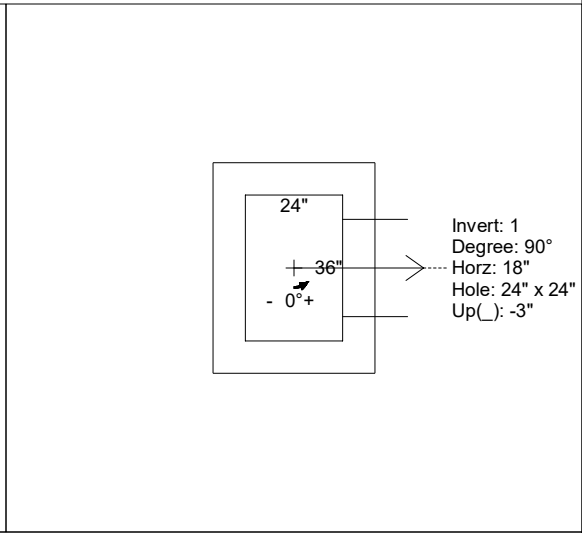
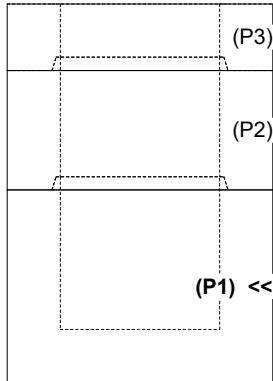

INSIDE WALL DIMENSIONS

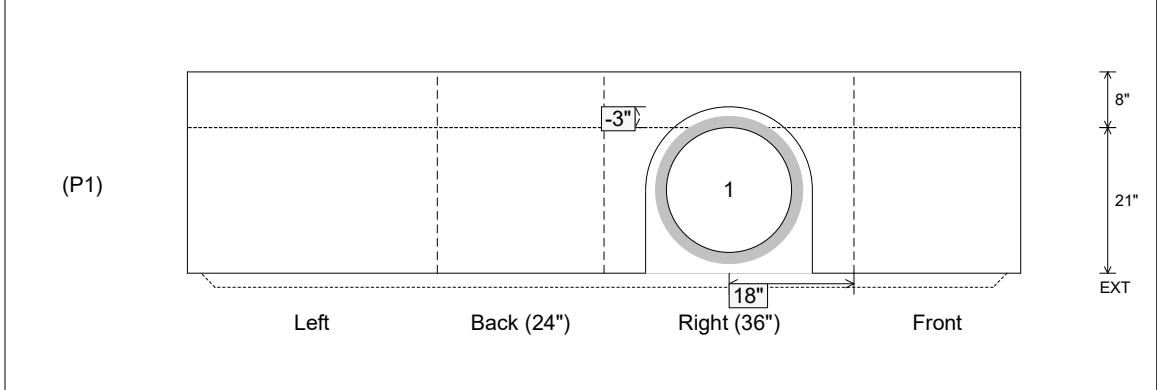

| | | | | |
|----------------------------------|---------------------------------|--|--|--|
| Coating (Int): Coating (Ext): | Seam Up: Tongue Seam Dn: n/a | Wall Thickness: 8" Floor Height: 8" | Height (Int): 21" Height (Ext): 29" | Weight (Net): 3194 lb Volume (Net): 0.82cu.yd |
|----------------------------------|---------------------------------|--|--|--|