

Job Name: 26-1315 - Ruby Drive Extension  
 Job Location: Madisonville, KY  
 Contractor: Steve Pleasant Excavating

Plant: 100  
 3/31/2026 10:53:16 AM

Tech: J. Horsley  
 PC: E. Bradley



**Structure ID: D-12 SS-MH**

**P3 MH048CN42**

**ECC CONE w/ 24" HOLE F/G**

- P4) 24" - CASTING HEIGHT - 7"
- P3) 48" - ECC CONE w/ 24" HOLE F/G - 42"
- P2) 48" - MH RISER T/G - 48"
- P1) 48" - MH BASE T/n - 18"
- 1) 48" - MH INVERT CHANNEL - FULL HEIGHT
- 1) JOINT WRAP - 0.065"x6"x50' CONSEAL CS212
- 1) JOINT WRAP PRIMER - CONSEAL CS-75 (1 gal.)
- 1) Inflow Dish FOR MC-315
- 1) CASTING - HOE MC-315 Self Seal F/C Sanitary
- 2) 48" - Conseal CS-102 1.00" (Double)
- 2) PSX - 12-08 NYLO
- 9) MH Step ML-10-TDS-NCR - 10"

0 lb  
 3200 lb  
 3353 lb  
 2492 lb  
 1440 lb  
 0 lb  
 0 lb  
 2 lb  
 258 lb  
 0 lb  
 16 lb  
 0 lb

- Structure Notes:
1. PER ASTM C-478 SPECS
  2. CONCRETE: 4,000 PSI AT 28 DAYS
  3. REINFORCEMENT: PER ASTM A615
  4. STEPS REQUIRED
  5. HOE MC-315 FRAME & COVER "SANITARY" SUPPLIED BY ICAST
  6. HOE MC-315 INFLOW DISH SUPPLIED BY ICAST

Structure Total: 10761 lb

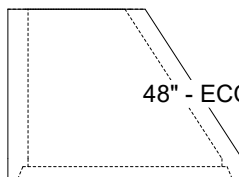
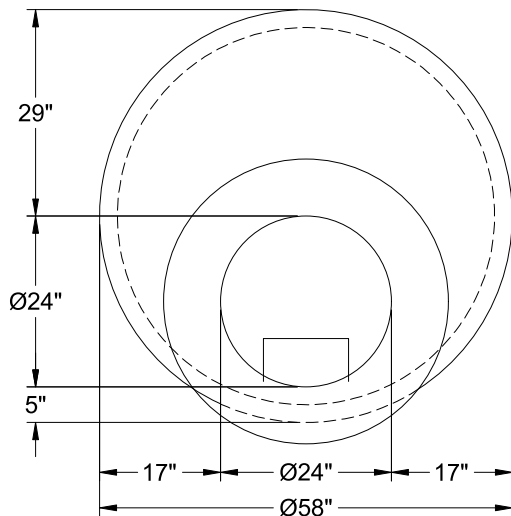

48" - ECC CONE w/ 24" HOLE F/G - 42" - (P3)

Coating (Int):  
 Coating (Ext):

Seam Up: Flat  
 Seam Dn: Groove

Wall Thickness: 5"

Height (Ext): 42"

Weight (Net): 3200 lb  
 Volume (Net): 0.5cu.yd