

Job Name: 26-1315 - Ruby Drive Extension
 Job Location: Madisonville, KY
 Contractor: Steve Pleasant Excavating

Plant: 100
 3/31/2026 9:20:28 AM

Tech: J. Horsley
 PC: E. Bradley



Structure ID: B-10 SS-MH

P1 MH048BA30

MH BASE T/n

P5) 24" - CASTING HEIGHT - 7"	0 lb
P4) 24" - GRADE RING F/F - 3"	202 lb
P3) 48" - ECC CONE w/ 24" HOLE F/G - 42"	3200 lb
P2) 48" - MH RISER T/G - 60"	4192 lb
P1) 48" - MH BASE T/n - 30"	3282 lb
1) 48" - MH INVERT CHANNEL - FULL HEIGHT	1440 lb
1) JOINT WRAP - 0.065"x6"x50' CONSEAL CS212	0 lb
1) JOINT WRAP PRIMER - CONSEAL CS-75 (1 gal.)	0 lb
1) Inflow Dish FOR MC-315	2 lb
1) CASTING - HOE MC-315 Self Seal F/C Sanitary	258 lb
2) 48" - Conseal CS-102 1.00" (Double)	0 lb
3) PSX - 12-08 NYLO	24 lb
11) MH Step ML-10-TDS-NCR - 10"	0 lb
Structure Total:	12600 lb

Structure Notes:
 1. PER ASTM C-478 SPECS
 2. CONCRETE: 4,000 PSI AT 28 DAYS
 3. REINFORCEMENT: PER ASTM A615
 4. INVERT CHANNEL REQUIRED
 5. STEPS AT 0 DEGREES
 6. HOE MC-315 FRAME & COVER "SANITARY" SUPPLIED BY ICAST
 7. HOE MC-315 INFLOW DISH SUPPLIED BY ICAST

Rim: 454.21' Rim to Invert: 11.69' Slack: 0.28" Sump: 2" Step Position: 0°

Position	Elev	Angle	Ext. (cw)	Pipe	Pipe OD	Connector	Hole	Horz Size	Up ()	Offset
Invert 1	442.52'	0°	0"	8" PVC SDR35	8.5"	PSX 12-08 NYLO	12"	12.129"	0"	0"
Invert 2	442.62'	85°	43"	8" PVC SDR35	8.5"	PSX 12-08 NYLO	12"	12.129"	1.25"	0"
Invert 3	442.62'	170°	86"	8" PVC SDR35	8.5"	PSX 12-08 NYLO	12"	12.129"	1.25"	0"
Invert 4										
Invert 5										
Invert 6										
Invert 7										
Invert 8										

RIGHT-SIDE UP VIEW (int. dimensions)

UPSIDE-DOWN VIEW (int. dimensions)

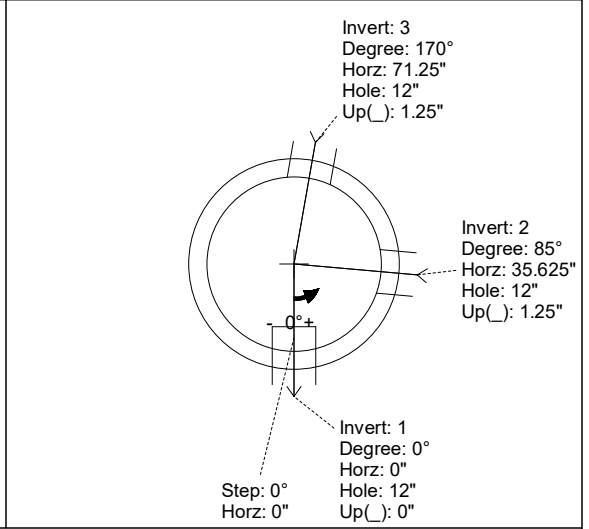
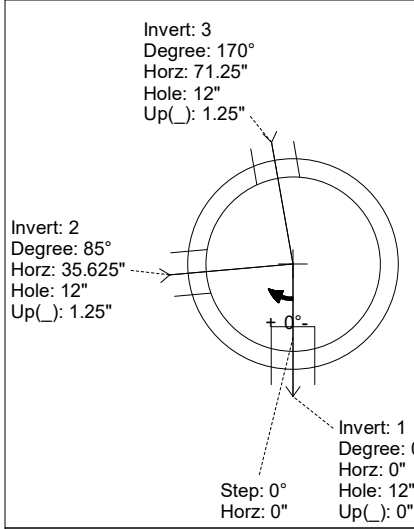
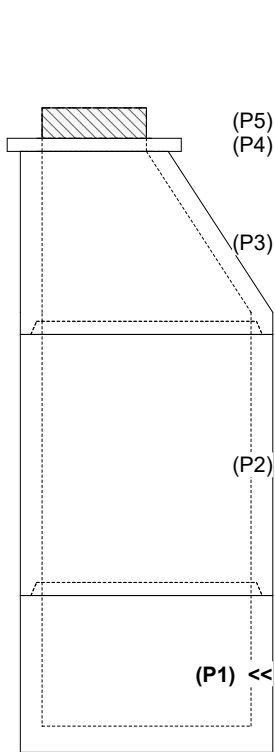

INSIDE WALL DIMENSIONS

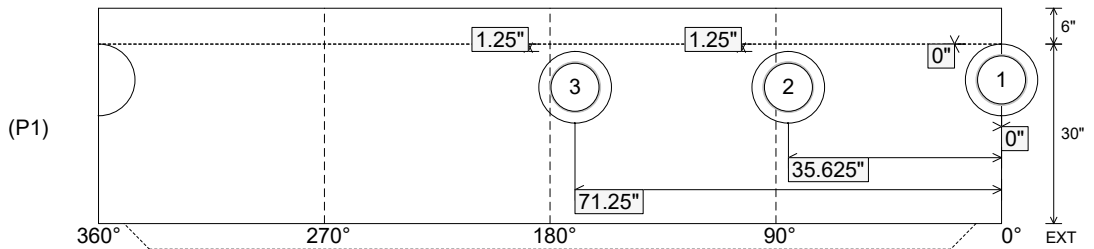

Coating (Int):
 Coating (Ext):

Seam Up: Tongue
 Seam Dn: n/a

Wall Thickness: 5"
 Floor Height: 6"

Height (Int): 30"
 Height (Ext): 36"

Weight (Net): 3282 lb
 Volume (Net): 0.84cu.yd

Job Name: 26-1315 - Ruby Drive Extension
 Job Location: Madisonville, KY
 Contractor: Steve Pleasant Excavating

Plant: 100
 3/31/2026 9:20:28 AM

Tech: J. Horsley
 PC: E. Bradley



Structure ID: B-10 SS-MH

P1 MH048BA30

MH BASE T/n

- P5) 24" - CASTING HEIGHT - 7"
- P4) 24" - GRADE RING F/F - 3"
- P3) 48" - ECC CONE w/ 24" HOLE F/G - 42"
- P2) 48" - MH RISER T/G - 60"
- P1) 48" - MH BASE T/n - 30"
- 1) 48" - MH INVERT CHANNEL - FULL HEIGHT
- 1) JOINT WRAP - 0.065"x6"x50' CONSEAL CS212
- 1) JOINT WRAP PRIMER - CONSEAL CS-75 (1 gal.)
- 1) Inflow Dish FOR MC-315
- 1) CASTING - HOE MC-315 Self Seal F/C Sanitary
- 2) 48" - Conseal CS-102 1.00" (Double)
- 3) PSX - 12-08 NYLO
- 11) MH Step ML-10-TDS-NCR - 10"

0 lb
 202 lb
 3200 lb
 4192 lb
 3282 lb
 1440 lb
 0 lb
 0 lb
 2 lb
 258 lb
 0 lb
 24 lb
 0 lb

 Structure Total: 12600 lb

- Structure Notes:
1. PER ASTM C-478 SPECS
 2. CONCRETE: 4,000 PSI AT 28 DAYS
 3. REINFORCEMENT: PER ASTM A615
 4. INVERT CHANNEL REQUIRED
 5. STEPS AT 0 DEGREES
 6. HOE MC-315 FRAME & COVER "SANITARY" SUPPLIED BY ICAST
 7. HOE MC-315 INFLOW DISH SUPPLIED BY ICAST

Rim: 454.21' Rim to Invert: 11.69' Slack: 0.28" Sump: 2" Step Position: 0°

Position	Elev	Angle	Ext. (cw)	Pipe	Pipe OD	Connector	Hole	Horz Size	Up ()	Offset
Invert 1	442.52'	0°	0"	8" PVC SDR35	8.5"	PSX 12-08 NYLO	12"	12.129"	0"	0"
Invert 2	442.62'	85°	43"	8" PVC SDR35	8.5"	PSX 12-08 NYLO	12"	12.129"	1.25"	0"
Invert 3	442.62'	170°	86"	8" PVC SDR35	8.5"	PSX 12-08 NYLO	12"	12.129"	1.25"	0"
Invert 4										
Invert 5										
Invert 6										
Invert 7										
Invert 8										

RIGHT-SIDE UP VIEW (int. dimensions)

UPSIDE-DOWN VIEW (int. dimensions)

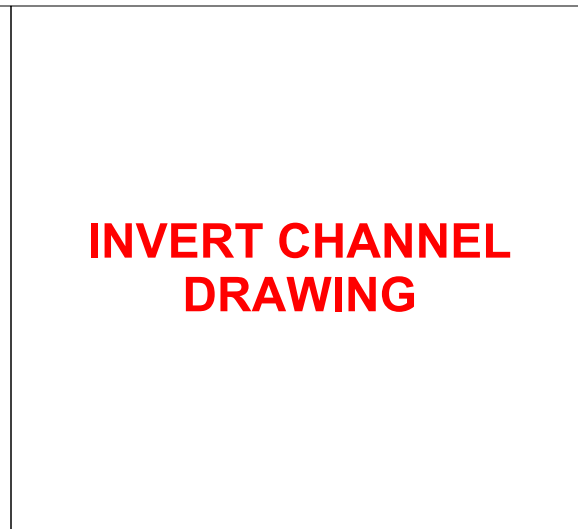
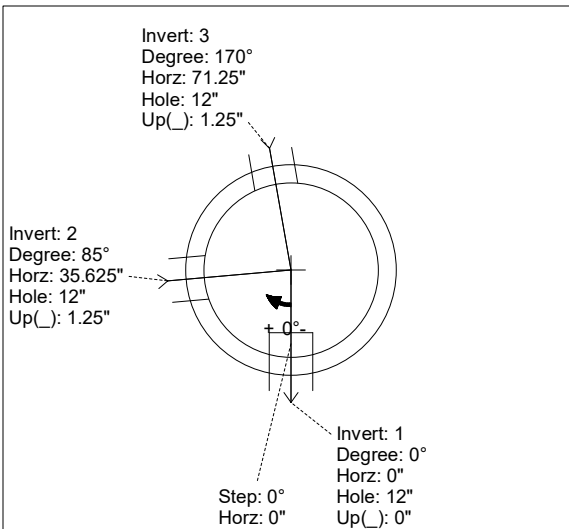
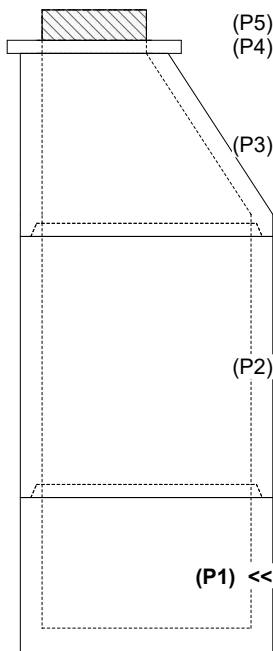

INSIDE WALL DIMENSIONS

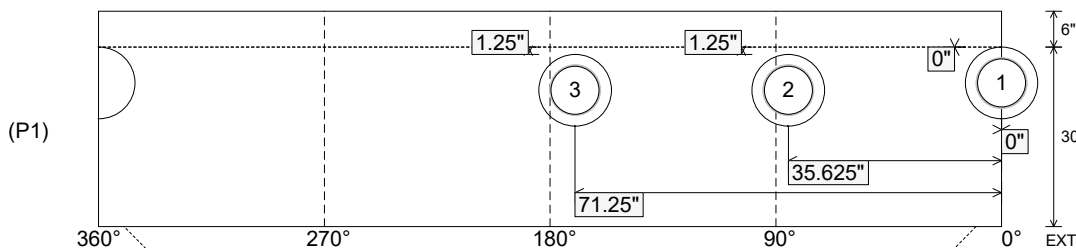

Coating (Int):
 Coating (Ext):

Seam Up: Tongue
 Seam Dn: n/a

Wall Thickness: 5"
 Floor Height: 6"

Height (Int): 30"
 Height (Ext): 36"

Weight (Net): 3282 lb
 Volume (Net): 0.84cu.yd