

Job Name: 26-1315 - Ruby Drive Extension
Job Location: Madisonville, KY
Contractor: Steve Pleasant Excavating

PC: E. Bradley
 TECH: J. Horsley
 Plant: 100



Structure ID: **A-9 SS-MH**

Spec: Sanitary
 Type: SAN.MH
 Size: 48"

Rim: 448.05'
 Invert: 439.78'
 Rim to Invert: 8.27'

Sump: 2"
 Floor (Top): 439.613'
 Floor Height: 6"

Floor (Bot): 439.113'
 Overall Height: 8.917'
 Slack: 0.24"

Structure Notes:

1. PER ASTM C-478 SPECS
2. CONCRETE: 4,000 PSI AT 28 DAYS
3. REINFORCEMENT: PER ASTM A615
4. INVERT CHANNEL REQUIRED
5. STEPS AT 0 DEGREES
6. HOE MC-315 FRAME & COVER "SANITARY" SUPPLIED BY ICAST
7. HOE MC-315 INFLOW DISH SUPPLIED BY ICAST

STRUCTURE SUMMARY:

- P5) 24" - CASTING HEIGHT - 7" 0 lb
 - P4) 24" - GRADE RING F/F - 4" 270 lb
 - P3) 48" - ECC CONE w/ 24" HOLE F/G - 30" 2050 lb
 - P2) 48" - MH RISER T/G - 36" 2515 lb
 - P1) 48" - MH BASE T/n - 24" 2911 lb
 - 1) 48" - MH INVERT CHANNEL - FULL HEIGHT 1440 lb
 - 1) JOINT WRAP - 0.065"x6"x50' CONSEAL CS212 0 lb
 - 1) JOINT WRAP PRIMER - CONSEAL CS-75 (1 gal.) 0 lb
 - 1) Inflow Dish FOR MC-315 2 lb
 - 1) CASTING - HOE MC-315 Self Seal F/C Sanitary 258 lb
 - 2) 48" - Conseal CS-102 1.00" (Double) 0 lb
 - 2) PSX - 12-08 NYLO 16 lb
 - 7) MH Step ML-10-TDS-NCR - 10" 0 lb
- Structure Total: 9462 lb**

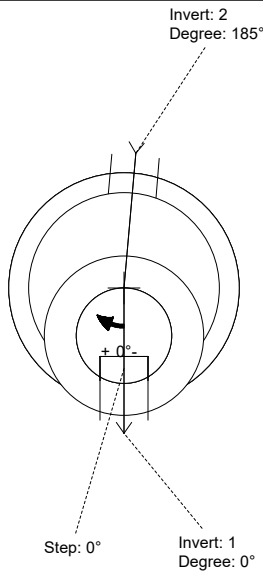

Position	Elev	Angle	Pipe	Pipe OD	Hole	Connector	Up (L)	Ref
Rim	448.05'							
Reducer								
Invert 1	439.78'	0°	8" PVC SDR35	8.5"	12"	PSX 12-08 NYLO	0"	P1
Invert 2	439.88'	185°	8" PVC SDR35	8.5"	12"	PSX 12-08 NYLO	1.25"	P1
Invert 3								
Invert 4								
Invert 5								
Invert 6								
Invert 7								
Invert 8								

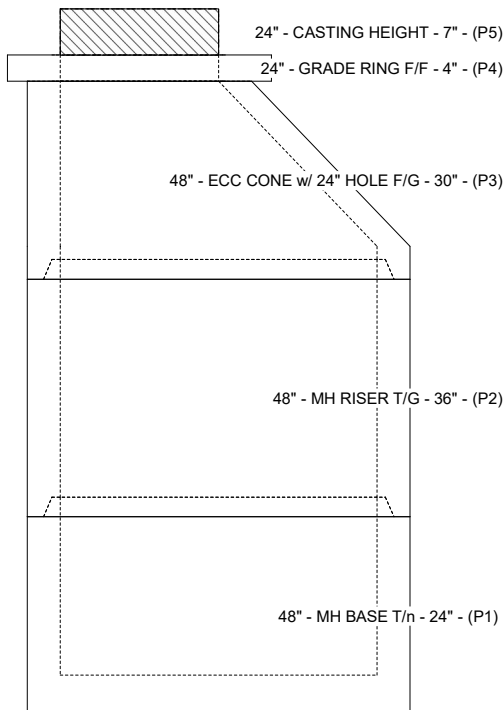

Cast (Int. Dim.) - Interior Dimensions

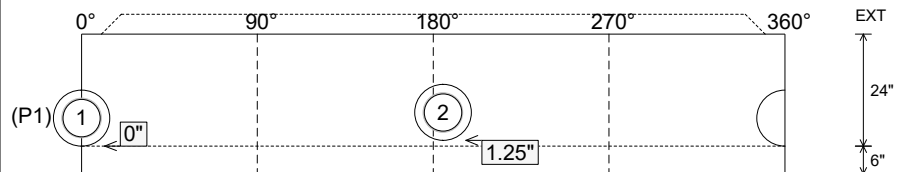

Submittal Drawing
 3/31/2026 8:28:59 AM

SUBMITTAL
 APPROVED BY: