

Job Name: 26-1315 - Ruby Drive Extension
 Job Location: Madisonville, KY
 Contractor: Steve Pleasant Excavating

Plant: 100

3/31/2026 10:53:14 AM

Tech: J. Horsley

PC: E. Bradley



Structure ID: A-9 SS-MH

P4 GR4

GRADE RING F/F

- P5) 24" - CASTING HEIGHT - 7"
- P4) 24" - GRADE RING F/F - 4"
- P3) 48" - ECC CONE w/ 24" HOLE F/G - 30"
- P2) 48" - MH RISER T/G - 36"
- P1) 48" - MH BASE T/n - 24"
- 1) 48" - MH INVERT CHANNEL - FULL HEIGHT
- 1) JOINT WRAP - 0.065"x6"x50' CONSEAL CS212
- 1) JOINT WRAP PRIMER - CONSEAL CS-75 (1 gal.)
- 1) Inflow Dish FOR MC-315
- 1) CASTING - HOE MC-315 Self Seal F/C Sanitary
- 2) 48" - Conseal CS-102 1.00" (Double)
- 2) PSX - 12-08 NYLO
- 7) MH Step ML-10-TDS-NCR - 10"

- 0 lb
- 270 lb
- 2050 lb
- 2515 lb
- 2911 lb
- 1440 lb
- 0 lb
- 0 lb
- 2 lb
- 258 lb
- 0 lb
- 16 lb
- 0 lb

Structure Total: 9462 lb

Structure Notes:

1. PER ASTM C-478 SPECS
2. CONCRETE: 4,000 PSI AT 28 DAYS
3. REINFORCEMENT: (1) #3 HOOP CENTERED (GRADE 60)

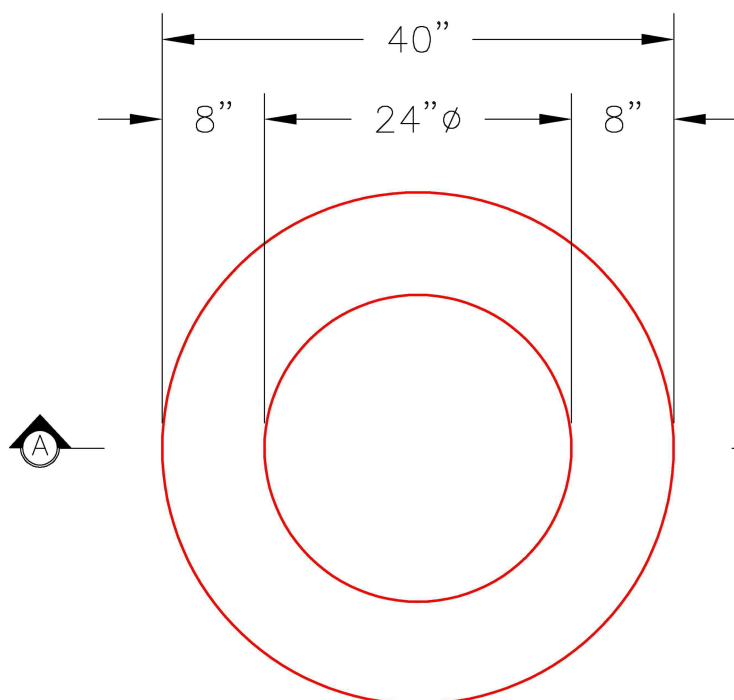

PLAN VIEW

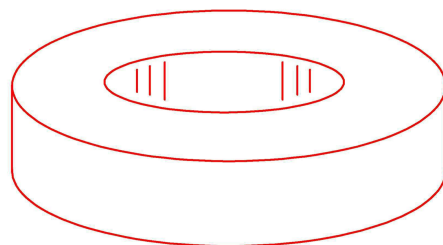

ISOMETRIC VIEW

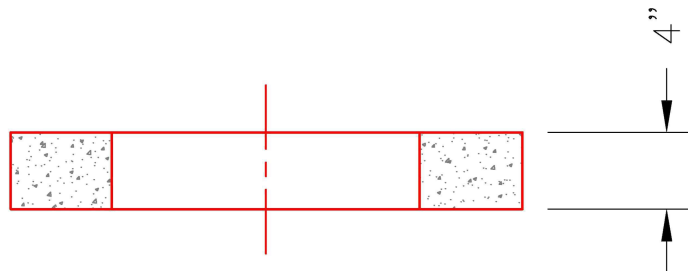

SECTION A-A

Coating (Int):
 Coating (Ext):

Seam Up: Flat
 Seam Dn: Flat

Wall Thickness: 8"

Height (Ext): 4"

Weight (Net): 270 lb
 Volume (Net): 0.07cu.yd