

Job Name: 26-1303 - Hale Ave & Woods Ferry Rd. Stormwater  
 Job Location: Gallatin, TN 37066  
 Contractor: Stewart Richey

Plant: 100  
 4/29/2026 6:15:47 PM

Tech: Jared - F  
 PC: T. Lewis



**Structure ID: 126-18 ST-OCS**

**P1 BX4848-08BAVF-EB**

**BX BASE w/FLANGE 08W/08F/06EF F/n**

- P2) 48" x 48" - CASTING HEIGHT - 0"
- P1) 48" x 48" - BX BASE w/FLANGE 08W/08F/06EF F/n - 60"
- 1) CASTING - TRASHRACKS LFG-4848-P Flat Inlet Grate
- 1) 48" x 48" - Conseal CS-102 1.00"
- 1) Hole - 22
- 1) Hole - 2

0 lb  
 12642 lb  
 83 lb  
 0 lb  
 0 lb  
 0 lb  
 -----  
 Structure Total: 12725 lb

**Structure Notes:**  
 1. PER ASTM C913 SPECIFICATIONS.  
 2. CONCRETE = 4,000 PSI AT 28 DAYS.  
 3. NO STEPS AND NO INVERT CHANNEL.  
 4. CASTING BY ICAST (TRASHRACKS LFG-4848-P FLAT INLET GRATE).

REINFORCING PER ASTM A615 (GRADE 60).  
 - WALLS (As .12) #5 BARS AT 12" C.C.E.W.  
 - FLOOR (As .12) #5 BARS AT 12" C.C.E.W.

Rim: 562.5' Rim to Invert: 3.5' Slack: 0" Sump: 18" Step Position:

Position	Elev	Angle	Ext. (cw)	Pipe	Pipe OD	Connector	Hole	Horz Size	Up ( )	Offset
Invert 1	559'	0°	32"	15" RCP B WALL	19.5"	Hole 22	22"	22"	15.75"	0"
Invert 2	559.1'	180°	32"	2" Orifice	2"	Hole 2	2"	2"	19.25"	0"
Invert 3										
Invert 4										
Invert 5										
Invert 6										
Invert 7										
Invert 8										

RIGHT-SIDE UP VIEW (int. dimensions)

UPSIDE-DOWN VIEW (int. dimenions)

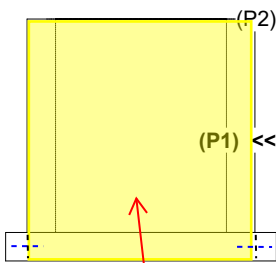

**1ST POUR (48"x48" x 60" TALL MONO BASE)**

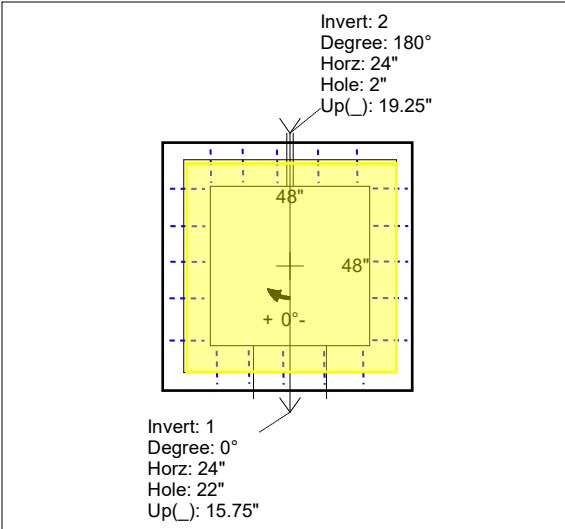

**1ST POUR = 11,796 LBS  
 2ND POUR = 846 LBS**

INSIDE WALL DIMENSIONS

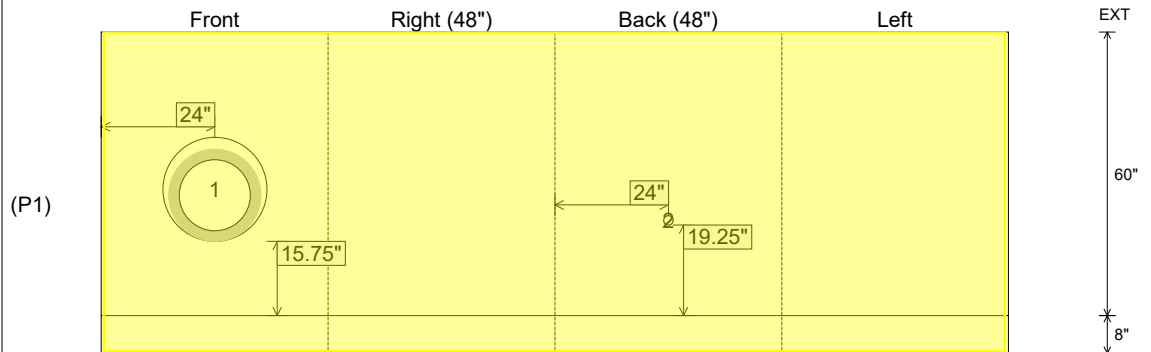

Coating (Int):  
 Coating (Ext):

Seam Up: Flat  
 Seam Dn: n/a

Wall Thickness: 8"  
 Floor Height: 8"

Height (Int): 60"  
 Height (Ext): 68"

Weight (Net): 12642 lb  
 Volume (Net): 3.23cu.yd

Job Name: 26-1303 - Hale Ave & Woods Ferry Rd. Stormwater  
 Job Location: Gallatin, TN 37066  
 Contractor: Stewart Richey

Plant: 100  
 4/29/2026 6:15:47 PM

Tech: Jared - F  
 PC: T. Lewis



**Structure ID: 126-18 ST-OCS**

**P1 BX4848-08BAVF-EB**

**BX BASE w/FLANGE 08W/08F/06EF F/n**

- P2) 48" x 48" - CASTING HEIGHT - 0"
- P1) 48" x 48" - BX BASE w/FLANGE 08W/08F/06EF F/n - 60"
- 1) CASTING - TRASHRACKS LFG-4848-P Flat Inlet Grate
- 1) 48" x 48" - Conseal CS-102 1.00"
- 1) Hole - 22
- 1) Hole - 2

0 lb  
 12642 lb  
 83 lb  
 0 lb  
 0 lb  
 0 lb  
 0 lb  
 Structure Total: 12725 lb

**Structure Notes:**  
 1. PER ASTM C913 SPECIFICATIONS.  
 2. CONCRETE = 4,000 PSI AT 28 DAYS.  
 3. NO STEPS AND NO INVERT CHANNEL.  
 4. CASTING BY ICAST (TRASHRACKS LFG-4848-P FLAT INLET GRATE).

REINFORCING PER ASTM A615 (GRADE 60).  
 - WALLS (As .12) #5 BARS AT 12" C.C.E.W.  
 - FLOOR (As .12) #5 BARS AT 12" C.C.E.W.

Rim: 562.5' Rim to Invert: 3.5' Slack: 0" Sump: 18" Step Position:

Position	Elev	Angle	Ext. (cw)	Pipe	Pipe OD	Connector	Hole	Horz Size	Up ( )	Offset
Invert 1	559'	0°	32"	15" RCP B WALL	19.5"	Hole 22	22"	22"	15.75"	0"
Invert 2	559.1'	180°	32"	2" Orifice	2"	Hole 2	2"	2"	19.25"	0"
Invert 3										
Invert 4										
Invert 5										
Invert 6										
Invert 7										
Invert 8										

RIGHT-SIDE UP VIEW (int. dimensions)

UPSIDE-DOWN VIEW (int. dimenions)

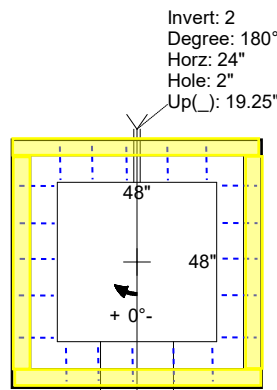

**1ST POUR = 11,796 LBS  
 2ND POUR = 846 LBS**

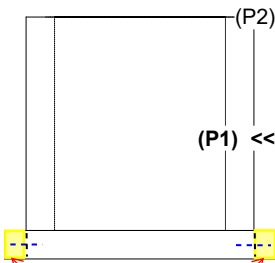

**2ND POUR (FLANGE w/ #5 BAR @ 12" O.C. DOWELS)**

INSIDE WALL DIMENSIONS

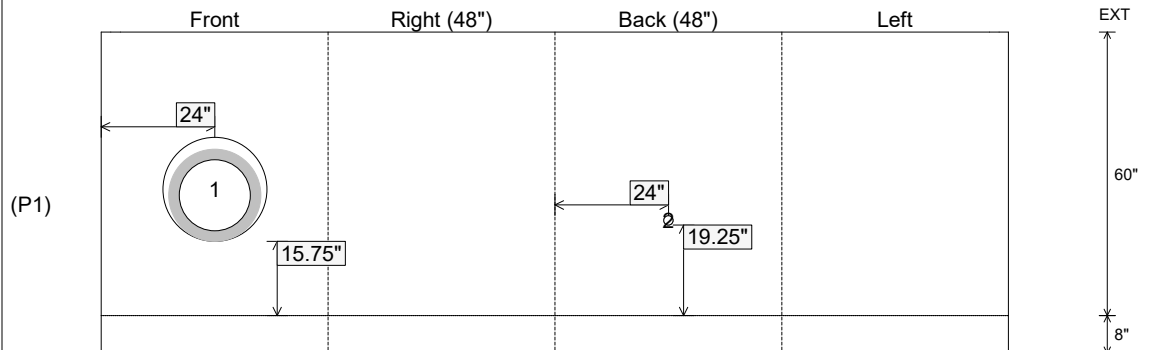

Coating (Int):  
 Coating (Ext):

Seam Up: Flat  
 Seam Dn: n/a

Wall Thickness: 8"  
 Floor Height: 8"

Height (Int): 60"  
 Height (Ext): 68"

Weight (Net): 12642 lb  
 Volume (Net): 3.23cu.yd