

Job Name: 26-1303 - Hale Ave & Woods Ferry Rd. Stormwater  
 Job Location: Gallatin, TN 37066  
 Contractor: Stewart Richey

Plant: 100  
 4/13/2026 7:05:12 PM

Tech: Jared - F  
 PC: T. Lewis



**Structure ID: 114-6 ST-CI**

**P1 MH048BA48**

**MH BASE T/n**

- P4) 30" x 30" - CASTING HEIGHT - 7.50"
- P3) 48" - MH FLAT TOP w/30"x30" Hole F/G - 12"
- P2) 48" - MH RISER T/G - 36"
- P1) 48" - MH BASE T/n - 48"
- 1) CASTING - JBS 3300 F/G/H - Single Curb Inlet
- 2) 48" - Conseal CS-102 1.00"
- 1) 30" x 30" - Conseal CS-102 1.00"
- 2) Hole - 32
- 7) MH Step ML-10-TDS-NCR - 10"

0 lb  
 1350 lb  
 2515 lb  
 3957 lb  
 250 lb  
 0 lb  
 0 lb  
 0 lb  
 0 lb  
 0 lb  
 Structure Total: 8072 lb

**Structure Notes:**  
 1. PER ASTM C478 SPECIFICATIONS.  
 2. CONCRETE = 4,000 PSI AT 28 DAYS.  
 3. NO INVERT CHANNEL.  
 4. CASTING BY ICAST (JBS 3300 F/G/H - SINGLE CURB INLET).

REINFORCING PER ASTM A615 (GRADE 60).  
 - TOP SLAB (As .62) #5 BARS AT 6" C.C.E.W..  
 - RISER/WALLS (As .12)  
 - FLOOR (As .31) #5 BARS AT 12" C.C.E.W.

Rim: 559.18' Rim to Invert: 8.56' Slack: 2.22' Sump: 3" Step Position: 90

Position	Elev	Angle	Ext. (cw)	Pipe	Pipe OD	Connector	Hole	Horz Size	Up ( )	Offset
Invert 1	550.62'	0°	0"	24" RCP B WALL	30"	Hole 32	32"	35.027"	0"	0"
Invert 2	550.62'	194°	98.25"	24" RCP B WALL	30"	Hole 32	32"	35.027"	0"	0"
Invert 3										
Invert 4										
Invert 5										
Invert 6										
Invert 7										
Invert 8										

RIGHT-SIDE UP VIEW (int. dimensions)

UPSIDE-DOWN VIEW (int. dimensions)

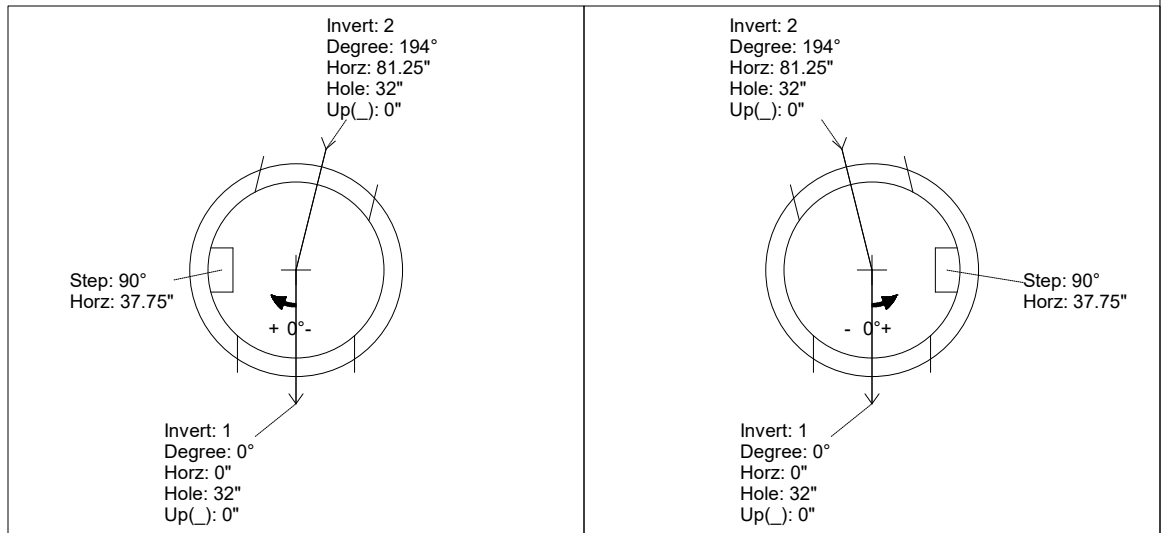

INSIDE WALL DIMENSIONS

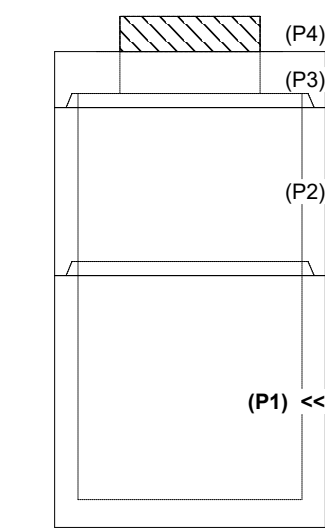
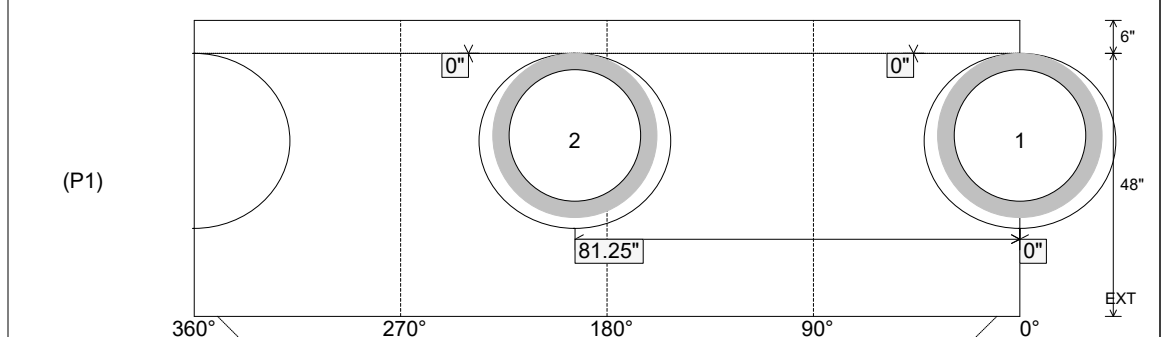

Coating (Int): Coating (Ext):	Seam Up: Tongue Seam Dn: n/a	Wall Thickness: 5" Floor Height: 6"	Height (Int): 48" Height (Ext): 54"	Weight (Net): 3957 lb Volume (Net): 1.01cu.yd
----------------------------------	---------------------------------	--	--	--