

Job Name: 26-1301 WCSC New Pre-K Classroom Addition
 Job Location: Newburgh, IN
 Contractor: Hahn Excavating, Inc.

Plant: Beaver Dam
 3/23/2026 10:51:54 AM

Tech: S. Felletter
 PC: E. Bradley



Structure ID: Str. 2-3 ST-MH

P2 MH048LD06SP

MH FLAT TOP SPEC. HT. (6") w/24" Hole CC F/F

P3) 24" - CASTING HEIGHT - 7"
 P2) 48" - MH FLAT TOP SPEC. HT. (6") w/24" Hole CC F/F - 6"
 P1) 48" - MH BASE Custom Ht F/n - 28"
 1) CASTING - HOE MC-315 F/C Vented
 1) 48" - Conseal CS-102 1.00"
 2) Hole - 20

0 lb
 1102 lb
 3016 lb
 258 lb
 0 lb
 0 lb

 4376 lb

Structure Notes:
 1. PER ASTM C478 SPECIFICATIONS.
 2. CONCRETE = 4,000 PSI AT 28 DAYS.
 3. CASTING BY ICAST (HOE MC-315 F/ VENTED COVER)

Structure Total:

REINFORCING PER ASTM A615 (GRADE 60).
 - TOP SLAB (As .62) #5 BARS AT 6" C.C.E.W..
 - RISER/WALLS (As .12)
 - FLOOR (As .31) #5 BARS AT 12" C.C.E.W.

NOTES:

1. MANUFACTURED TO ASTM C-478 (LATEST REVISION).
2. CONCRETE: 4,000 PSI AT 28 DAYS.
3. REINFORCING: #5 BAR @ 6" C.C. E.W. (GRADE 60).

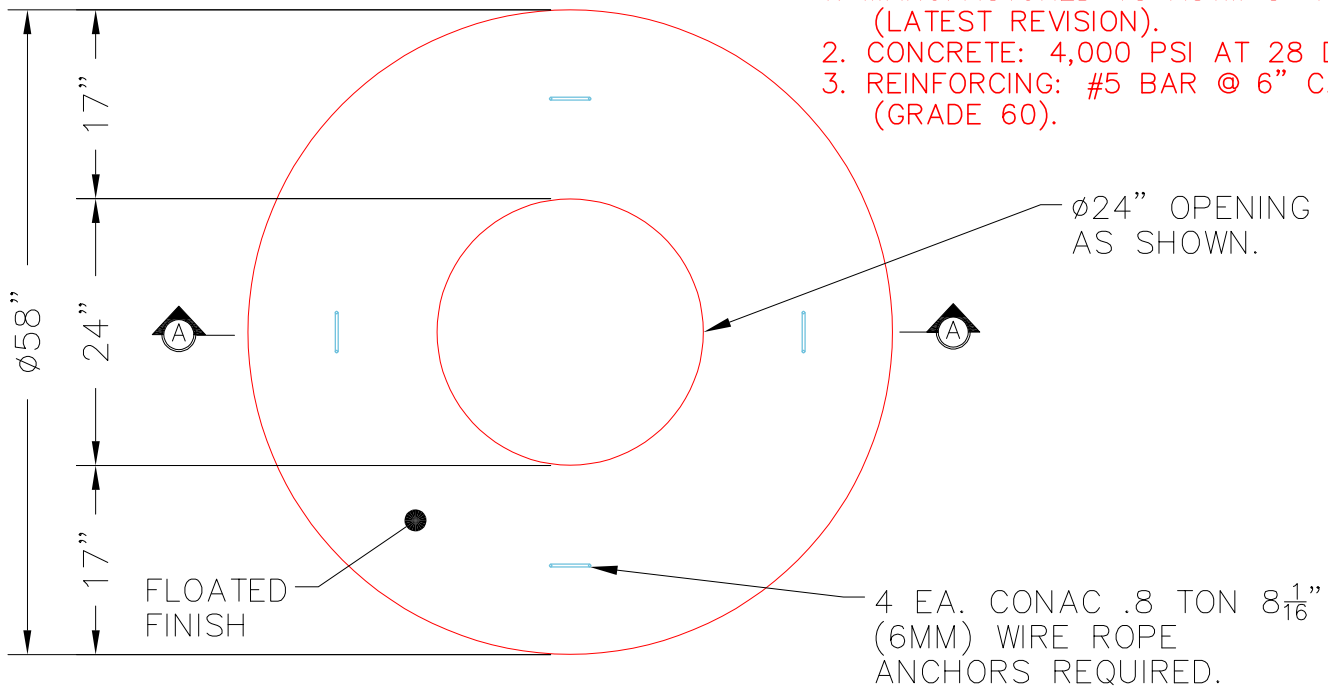

PLAN VIEW

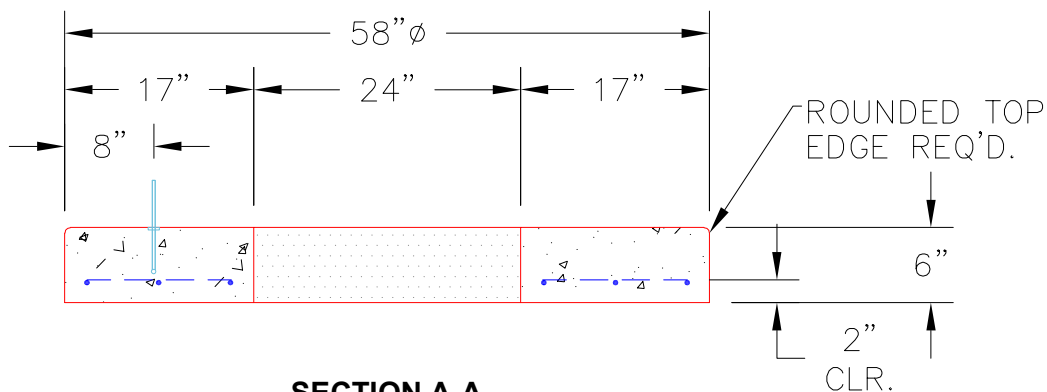

SECTION A-A

Coating (Int):
 Coating (Ext):

Seam Up: Flat
 Seam Dn: Flat

Wall Thickness: 5"

Height (Ext): 6"

Weight (Net): 1102 lb
 Volume (Net): 0.28cu.yd