

Job Name: 26-1232 - Mustang Village Apartments Ph.1
Job Location: Paducah, KY
Contractor: Wood Brothers

PC: T. Lewis
 TECH: Jared - F
 Plant: 100



Structure ID: **SSMH B-3-52 SS-MH**
 Spec: Sanitary Rim: 383.5' Sump: 2" Floor (Bot): 374.883'
 Type: SAN.MH Invert: 375.55' Floor (Top): 375.383' Overall Height: 8.583'
 Size: 48" Rim to Invert: 7.95' Floor Height: 6" Slack: 0.4"

Structure Notes:

1. PER ASTM C478 SPECIFICATIONS.
2. CONCRETE = 4,000 PSI AT 28 DAYS.
3. CASTING BY ICAST (HOE MC-375 F/C SANITARY)
4. INVERT CHANNEL TO EXTEND TO OPPOSITE WALL AT 180 DEGREES.

REINFORCING PER ASTM A615 (GRADE 60).
 - CONE (As .12)
 - RISER/WALLS (As .12)
 - FLOOR (As .31) #5 BARS AT 12" C.C.E.W.

STRUCTURE SUMMARY:

P4) 24" - CASTING HEIGHT - 7"	0 lb
P3) 48" - ECC CONE w/ 24" HOLE - 24"	1550 lb
P2) 48" - MH RISER - 36"	2515 lb
P1) 48" - MH BASE - 30"	3378 lb
1) JOINT WRAP - 0.065"x6"x50' CONSEAL CS212	0 lb
1) JOINT WRAP PRIMER - CONSEAL CS-75 (1 gal.)	0 lb
1) 48" - MH INVERT CHANNEL - FULL HEIGHT	1440 lb
1) CASTING - HOE MC-375 F/C Sanitary	271 lb
2) 48" - Conseal CS-102 1.00" (Double)	0 lb
1) PSX - 12-08 NYLO	8 lb
7) MH Step ML-10-TDS-NCR - 10"	0 lb
Structure Total:	9162 lb

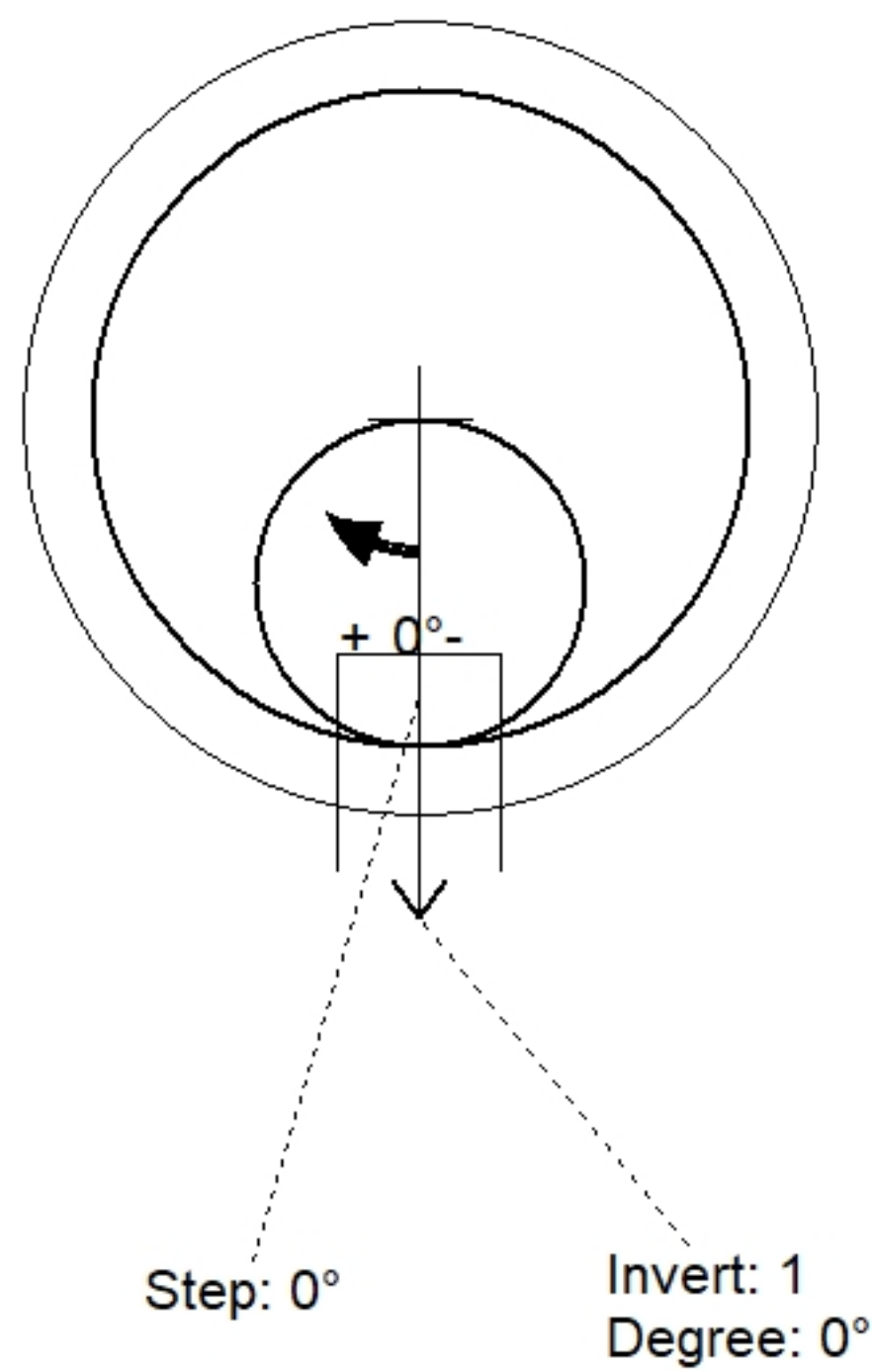

Position	Elev	Angle	Pipe	Pipe OD	Hole	Connector	Up ()	Ref
Rim	383.5'							
Reducer								
Invert 1	375.55'	0°	8" PVC SDR35	8.5"	12"	PSX 12-08 NYLO	0"	P1
Invert 2								
Invert 3								
Invert 4								
Invert 5								
Invert 6								
Invert 7								
Invert 8								

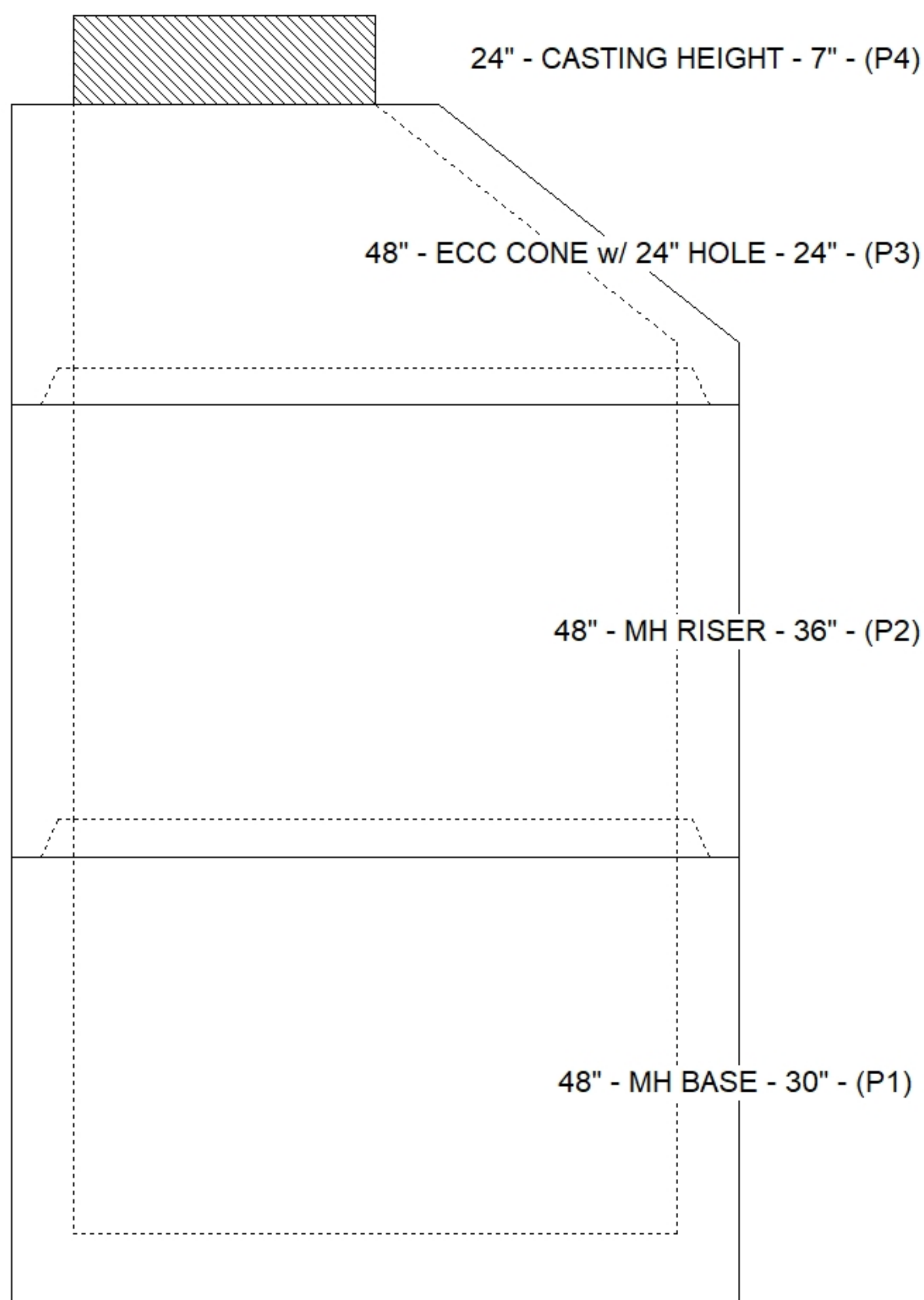

Default - Interior Dimensions

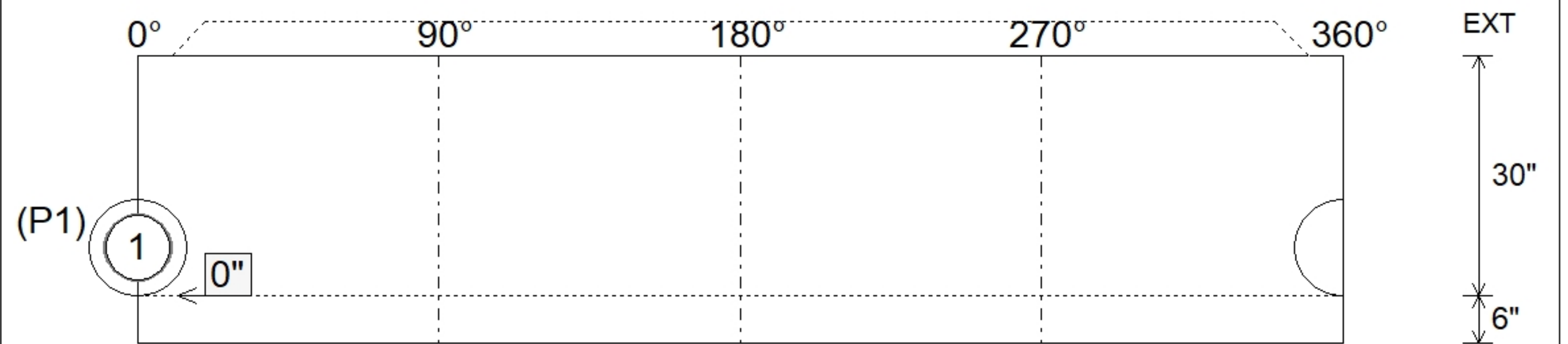

Submittal Drawing
 4/24/2026 2:05:43 PM

SUBMITTAL
 APPROVED BY: