

Job Name: 26-1232 - Mustang Village Apartments Ph.1
 Job Location: Paducah, KY
 Contractor: Wood Brothers

Plant: 100
 4/21/2026 8:03:30 PM

Tech: Jared - F
 PC: T. Lewis



Structure ID: S44-44 ST-DBI

P1 BX2424-08BA30

BOX BASE 8inW, 8inF/n

- P2) 24" x 24" - CASTING HEIGHT - 0"
- P1) 24" x 24" - BOX BASE 8inW, 8inF F/n - 30"
- 1) CASTING - HOE HOE-315 ANGLE F/G
- 1) 24" x 24" - Conseal CS-102 1.00"
- 1) Hole - 18

0 lb
 3470 lb
 258 lb
 0 lb
 0 lb

 0 lb
 Structure Total: 3728 lb

- Structure Notes:
1. PER ASTM C913 SPECIFICATIONS.
 2. CONCRETE = 4,000 PSI AT 28 DAYS.
 3. NO STEPS AND NO INVERT CHANNEL.
 4. CASTING BY ICAST (HOE-315 ANGLE F/G)

REINFORCING PER ASTM A615 (GRADE 60).
 - WALLS (As .12) #5 BARS AT 12" C.C.E.W.
 - FLOOR (As .12) #5 BARS AT 12" C.C.E.W.

Rim: 379.9' Rim to Invert: 2.5' Slack: 0" Sump: 0" Step Position:

Position	Elev	Angle	Ext. (cw)	Pipe	Pipe OD	Connector	Hole	Horz Size	Up (↓)	Offset
Invert 1	377.4'	20°	23"	12" HDPE	14.5"	Hole 18	18"	19.155"	-1.25"	-4"
Invert 2										
Invert 3										
Invert 4										
Invert 5										
Invert 6										
Invert 7										
Invert 8										

RIGHT-SIDE UP VIEW (int. dimensions)

UPSIDE-DOWN VIEW (int. dimensions)

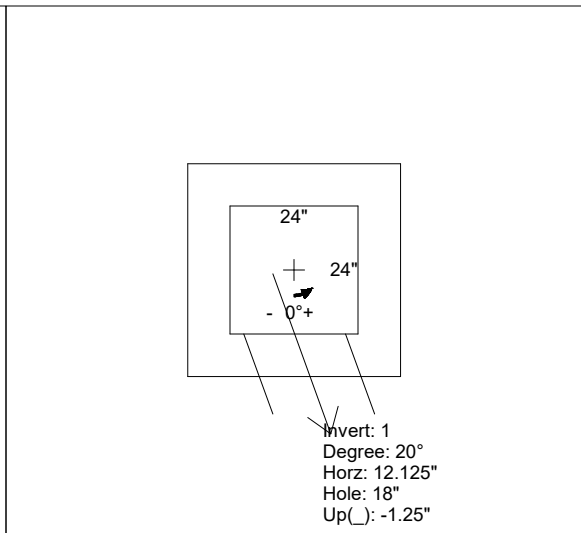
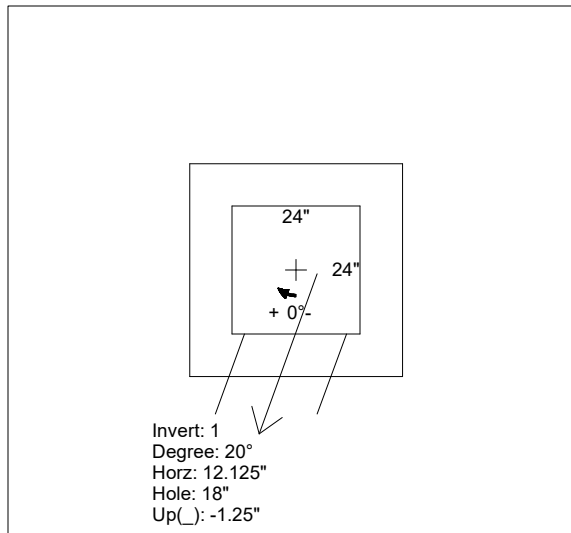
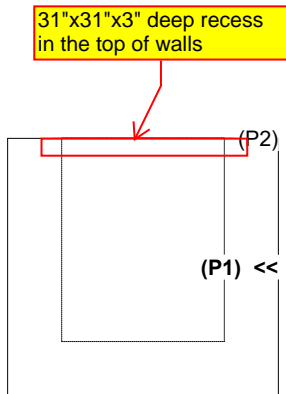

INSIDE WALL DIMENSIONS

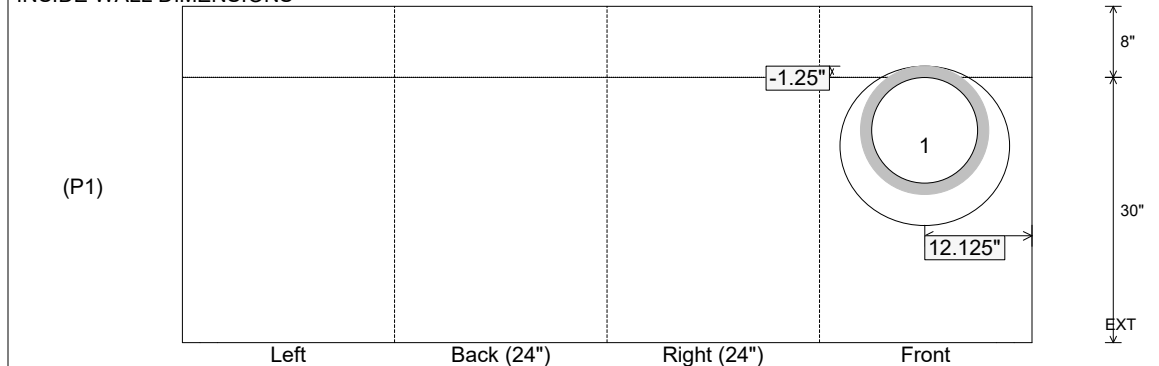

Coating (Int):
 Coating (Ext):

Seam Up: Flat
 Seam Dn: n/a

Wall Thickness: 8"
 Floor Height: 8"

Height (Int): 30"
 Height (Ext): 38"

Weight (Net): 3470 lb
 Volume (Net): 0.89cu.yd