

Job Name: 26-1232 - Mustang Village Apartments Ph.1  
 Job Location: Paducah, KY  
 Contractor: Wood Brothers

Plant: 100  
 4/21/2026 8:03:11 PM

Tech: Jared - F  
 PC: T. Lewis



**Structure ID: S20-20 DBI13G**

**P1 BX1527-08BAVF**

**BOX BASE 8inW, 8inF, Variable Ht F/n**

- P2) 15" x 27" - P.I.P. - BY OTHERS - 8"
- P1) 15" x 27" - BOX BASE 8inW, 8inF, Variable Ht F/n - 22"
- 1) CASTING - HOE KY-230-G F/G (GRADE)
- 1) 15" x 27" - Conseal CS-102 1.00"
- 1) Hole - 18
- 2) Hole - 4

0 lb  
 2420 lb  
 237 lb  
 0 lb  
 0 lb  
 0 lb  
 -----  
 Structure Total: 2657 lb

**Structure Notes:**  
 1. KYTC DBI TYPE 13G / ASTM C-913 SPEC'S.  
 2. CONCRETE = 4,000 PSI AT 28 DAYS.  
 3. CASTING BY ICAST (HOE KY-230-G F/G (GRADE)).

REINFORCING PER ASTM A615 (GRADE 60).  
 - WALLS (As .31) #5 BARS AT 12" C.C.E.W..  
 - FLOOR (As .31) #5 BARS AT 12" C.C.E.W.

Rim: 381.71' Rim to Invert: 2.5' Slack: 0" Sump: 0" Step Position:

Position	Elev	Angle	Ext. (cw)	Pipe	Pipe OD	Connector	Hole	Horz Size	Up ( )	Offset
Invert 1	379.21'	90°	21.5"	12" HDPE	14.5"	Hole 18	18"	18"	-1.25"	0"
Invert 2	380.38'	90°	10.5"	4" WEEP HOLE	4"	Hole 4	4"	4"	14"	-11"
Invert 3	380.38'	270°	21.5"	4" WEEP HOLE	4"	Hole 4	4"	4"	14"	0"
Invert 4										
Invert 5										
Invert 6										
Invert 7										
Invert 8										

RIGHT-SIDE UP VIEW (int. dimensions)

UPSIDE-DOWN VIEW (int. dimenions)

#5 BAR EXTENDED  
 12" @ 12" C.C.

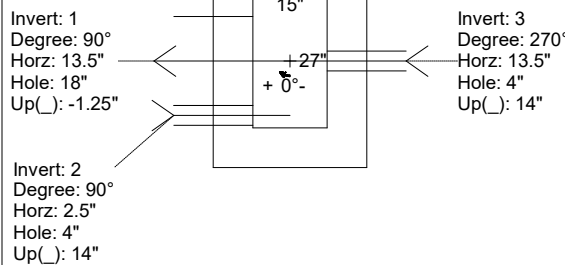
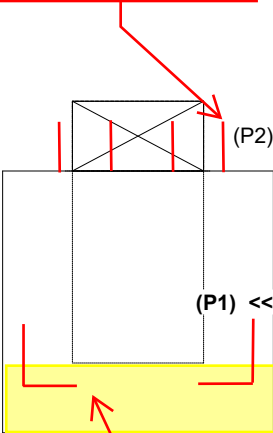

1ST POUR (FLOOR) = 1,525 LBS  
 2ND POUR (WALLS) = 895 LBS

1ST POUR (FLOOR)  
 STUB #5 L BARS OUT  
 TOP FLOOR, SPA AT  
 12" C/C FOR  
 CONNECTING WALLS

INSIDE WALL DIMENSIONS

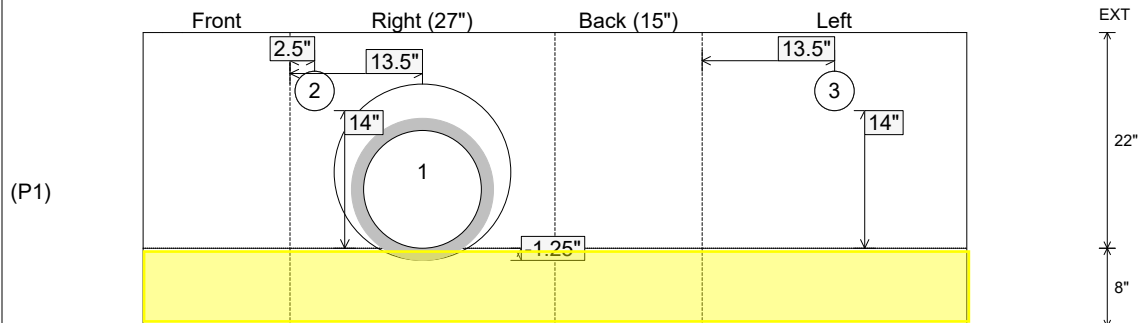

Coating (Int):  
 Coating (Ext):

Seam Up: Flat  
 Seam Dn: n/a

Wall Thickness: 8"  
 Floor Height: 8"

Height (Int): 22"  
 Height (Ext): 30"

Weight (Net): 2420 lb  
 Volume (Net): 0.62cu.yd

Job Name: 26-1232 - Mustang Village Apartments Ph.1  
 Job Location: Paducah, KY  
 Contractor: Wood Brothers

Plant: 100  
 4/21/2026 8:03:11 PM

Tech: Jared - F  
 PC: T. Lewis



**Structure ID: S20-20 DBI13G**

**P1 BX1527-08BAVF**

**BOX BASE 8inW, 8inF, Variable Ht F/n**

- P2) 15" x 27" - P.I.P. - BY OTHERS - 8"
- P1) 15" x 27" - BOX BASE 8inW, 8inF, Variable Ht F/n - 22"
- 1) CASTING - HOE KY-230-G F/G (GRADE)
- 1) 15" x 27" - Conseal CS-102 1.00"
- 1) Hole - 18
- 2) Hole - 4

0 lb  
 2420 lb  
 237 lb  
 0 lb  
 0 lb  
 0 lb  
 -----  
 Structure Total: 2657 lb

**Structure Notes:**  
 1. KYTC DBI TYPE 13G / ASTM C-913 SPEC'S.  
 2. CONCRETE = 4,000 PSI AT 28 DAYS.  
 3. CASTING BY ICAST (HOE KY-230-G F/G (GRADE)).

REINFORCING PER ASTM A615 (GRADE 60).  
 - WALLS (As .31) #5 BARS AT 12" C.C.E.W..  
 - FLOOR (As .31) #5 BARS AT 12" C.C.E.W.

Rim: 381.71' Rim to Invert: 2.5' Slack: 0" Sump: 0" Step Position:

Position	Elev	Angle	Ext. (cw)	Pipe	Pipe OD	Connector	Hole	Horz Size	Up ( )	Offset
Invert 1	379.21'	90°	21.5"	12" HDPE	14.5"	Hole 18	18"	18"	-1.25"	0"
Invert 2	380.38'	90°	10.5"	4" WEEP HOLE	4"	Hole 4	4"	4"	14"	-11"
Invert 3	380.38'	270°	21.5"	4" WEEP HOLE	4"	Hole 4	4"	4"	14"	0"
Invert 4										
Invert 5										
Invert 6										
Invert 7										
Invert 8										

RIGHT-SIDE UP VIEW (int. dimensions)

UPSIDE-DOWN VIEW (int. dimenions)

#5 BAR EXTENDED  
 12" @ 12" C.C.

1ST POUR (FLOOR) = 1,525 LBS  
 2ND POUR (WALLS) = 895 LBS

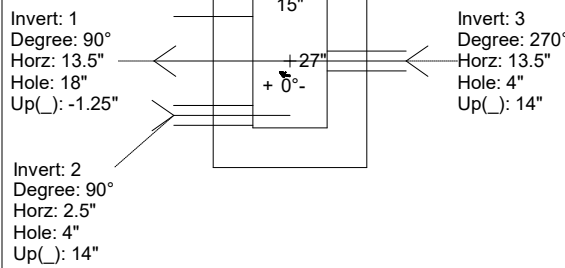
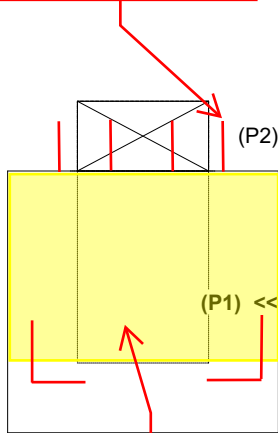

INSIDE WALL DIMENSIONS

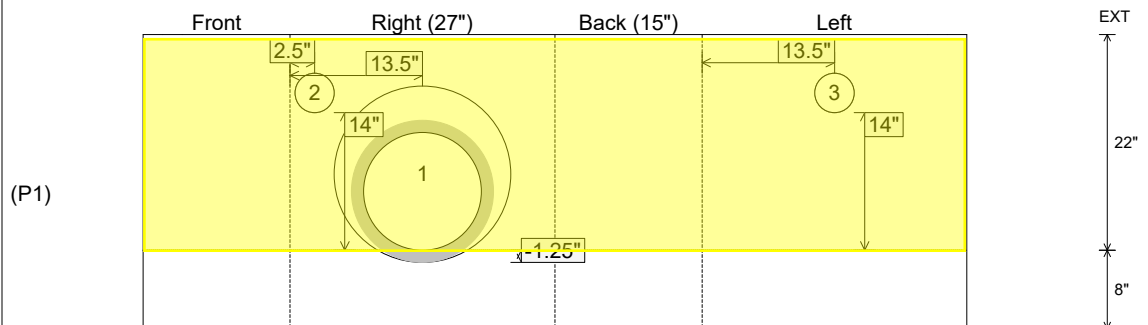

Coating (Int):  
 Coating (Ext):

Seam Up: Flat  
 Seam Dn: n/a

Wall Thickness: 8"  
 Floor Height: 8"

Height (Int): 22"  
 Height (Ext): 30"

Weight (Net): 2420 lb  
 Volume (Net): 0.62cu.yd