

**Job Name: 26-1232 - Mustang Village Apartments Ph.1**  
**Job Location: Paducah, KY**  
**Contractor: Wood Brothers**

PC: T. Lewis  
 TECH: Jared - F  
 Plant: 100



Structure ID: S15-15 ST-JB

Spec: Storm  
 Type: STM.MH  
 Size: 60"

Rim: 376.95'  
 Invert: 372.24'  
 Rim to Invert: 4.71'

Sump: 2.55"  
 Floor (Top): 372.028'  
 Floor Height: 8"

Floor (Bot): 371.361'  
 Overall Height: 5.583'  
 Slack: 0.07"

**Structure Notes:**

1. PER ASTM C478 SPECIFICATIONS.
2. CONCRETE = 4,000 PSI AT 28 DAYS.
3. NO INVERT CHANNEL.
4. CASTING BY ICAST (HOE MC-375 F/C STORM).

REINFORCING PER ASTM A615 (GRADE 60).  
 - TOP SLAB (As .62) #5 BARS AT 6" C.C.E.W..  
 - RISER/WALLS (As .18)  
 - FLOOR (As .37) #5 BARS AT 10" C.C.E.W.

**STRUCTURE SUMMARY:**

|  |                |
|--|----------------|
| P3) 24" - CASTING HEIGHT - 7"              | 0 lb           |
| P2) 60" - MH FLAT TOP w/ 24" ECC Hole - 8" | 2429 lb        |
| P1) 60" - MH BASE Custom Ht - 44"          | 5977 lb        |
| 1) CASTING - HOE MC-375 F/C Storm          | 271 lb         |
| 1) 60" - Conseal CS-102 1.00"              | 0 lb           |
| 1) Hole - 38                               | 0 lb           |
| 2) Hole - 30                               | 0 lb           |
| 3) MH Step ML-10-TDS-NCR - 10"             | 0 lb           |
| <b>Structure Total:</b>                    | <b>8677 lb</b> |

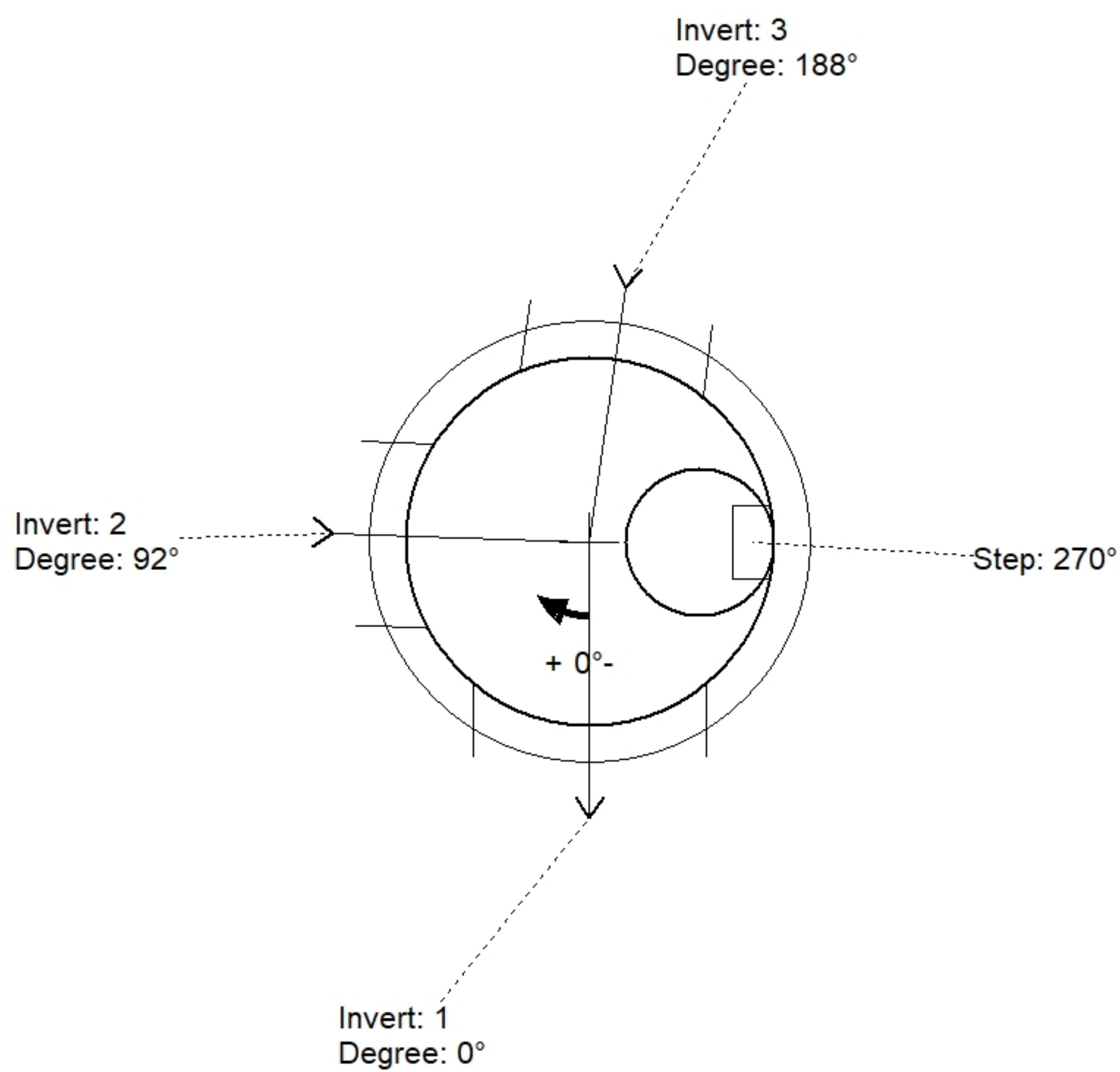

| Position | Elev    | Angle | Pipe     | Pipe OD | Hole | Connector | Up (") | Ref |
|----------|---------|-------|----------|---------|------|-----------|--------|-----|
| Rim      | 376.95' |       |          |         |      |           |        |     |
| Reducer  |         |       |          |         |      |           |        |     |
| Invert 1 | 372.24' | 0°    | 30" HDPE | 35.1"   | 38"  | Hole 38   | 0"     | P1  |
| Invert 2 | 372.24' | 92°   | 24" HDPE | 27.8"   | 30"  | Hole 30   | 0.65"  | P1  |
| Invert 3 | 372.24' | 188°  | 24" HDPE | 27.8"   | 30"  | Hole 30   | 0.65"  | P1  |
| Invert 4 |         |       |          |         |      |           |        |     |
| Invert 5 |         |       |          |         |      |           |        |     |
| Invert 6 |         |       |          |         |      |           |        |     |
| Invert 7 |         |       |          |         |      |           |        |     |
| Invert 8 |         |       |          |         |      |           |        |     |

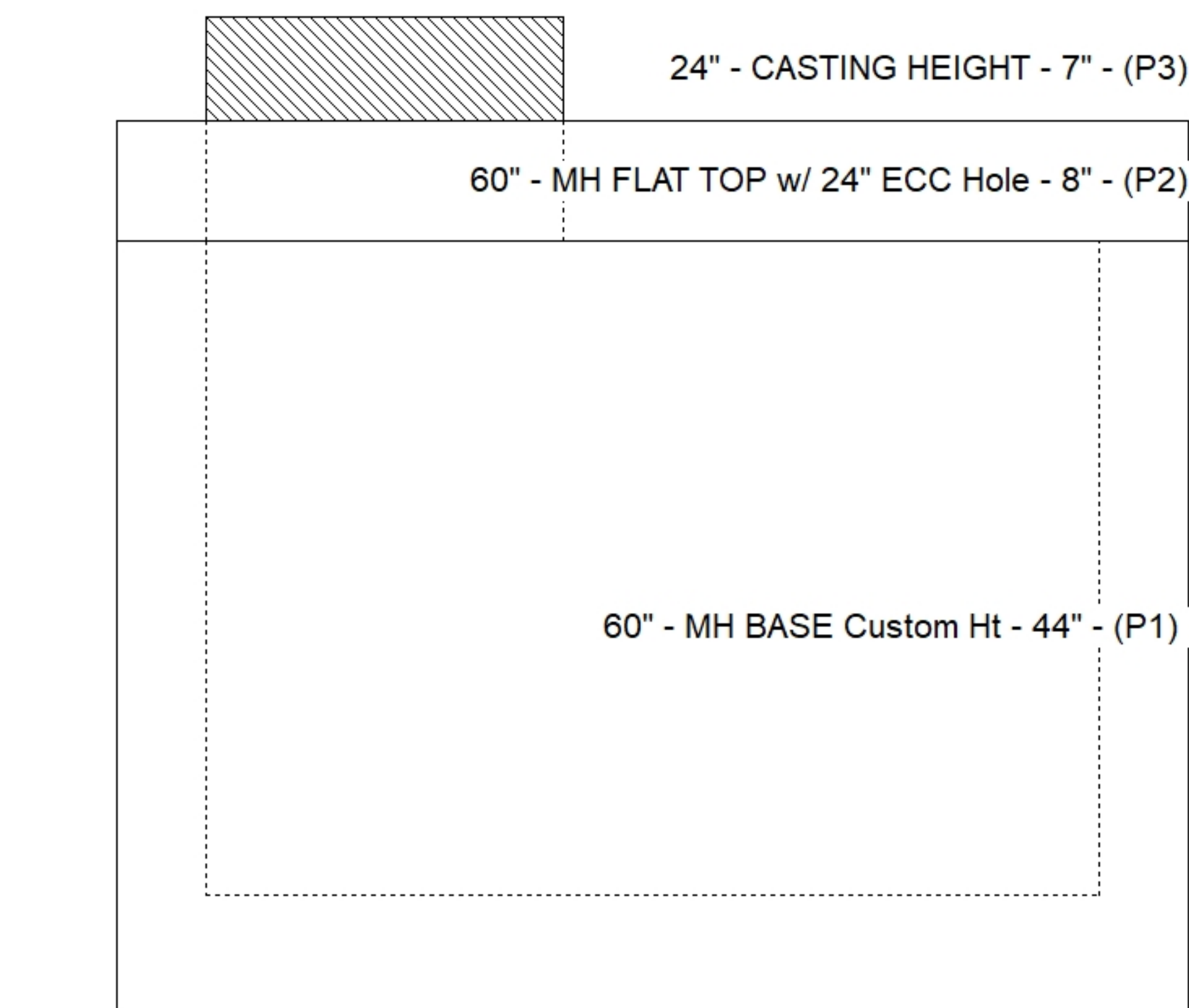

**Default - Interior Dimensions**

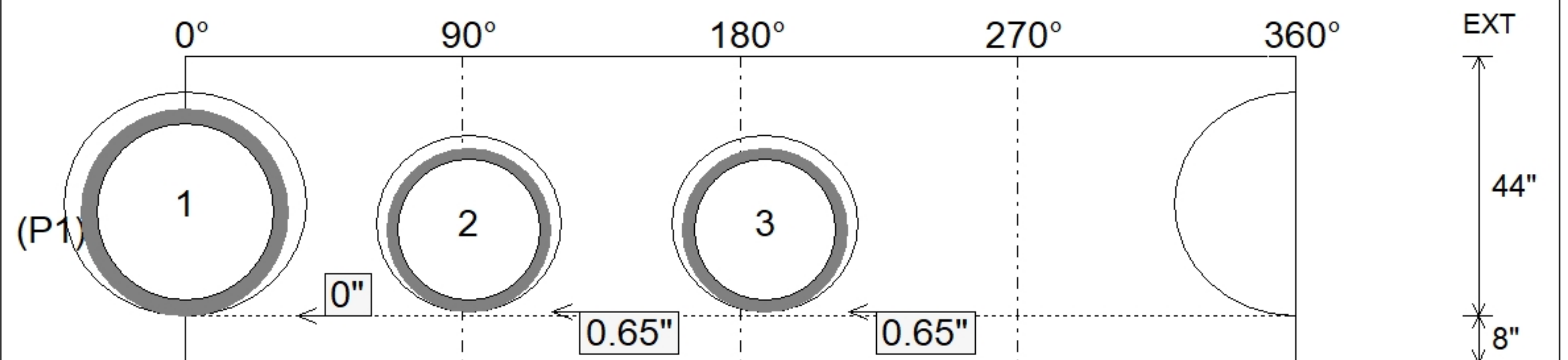

Submittal Drawing  
 4/24/2026 2:05:28 PM

SUBMITTAL  
 APPROVED BY: