

Structure ID: MH-83-6 MH3

P2 MH048RS36

MH RISER T/G

P5) 24" - CASTING HEIGHT - 7" P4) 24" - GRADE RING F/F - 4" P3) 48" - ECC CONE w/ 24" HOLE F/G - 30" P2) 48" - MH RISER T/G - 36" P1) 48" - MH BASE T/n - 48" 1) CASTING - HOE MC-375 F/C Storm 2) 48" - Conseal CS-102 1.00" 2) Hole - 30 1) Hole - 24 10) MH Step ML-10-TDS-NCR - 10"	0 lb 270 lb 2050 lb 2515 lb 3854 lb 271 lb 0 lb 0 lb 0 lb 0 lb ----- Structure Total: 8960 lb	Structure Notes: PLAN LABEL: 83 1. HOE MC-375 F/C STORM PROVIDED BY ICAST. 2. PER ASTM C478 SPECIFICATIONS. 3. CONCRETE = 4,000 PSI AT 28 DAYS. 4. REINFORCING PER ASTM A615 (GRADE 60). - CONE (As .12) - RISER/WALLS (As .12) - FLOOR (As .31) #5 BARS AT 12" C.C.E.W.
--------------------------------------------------------------------------------------------------------------------------------------------------------------------------------------------------------------------------------------------------------------------------------------------------------------------	--------------------------------------------------------------------------------------------------------------------------------	---------------------------------------------------------------------------------------------------------------------------------------------------------------------------------------------------------------------------------------------------------------------------------------------------------

Rim: 898.13' Rim to Invert: 10.34' Slack: 0.98" Sump: 1.9" Step Position: 172°

Position	Elev	Angle	Ext. (cw)	Pipe	Pipe OD	Connector	Hole	Horz Size	Up (L)	Offset
Invert 1										
Invert 2										
Invert 3										
Invert 4										
Invert 5										
Invert 6										
Invert 7										
Invert 8										

RIGHT-SIDE UP VIEW (int. dimensions)

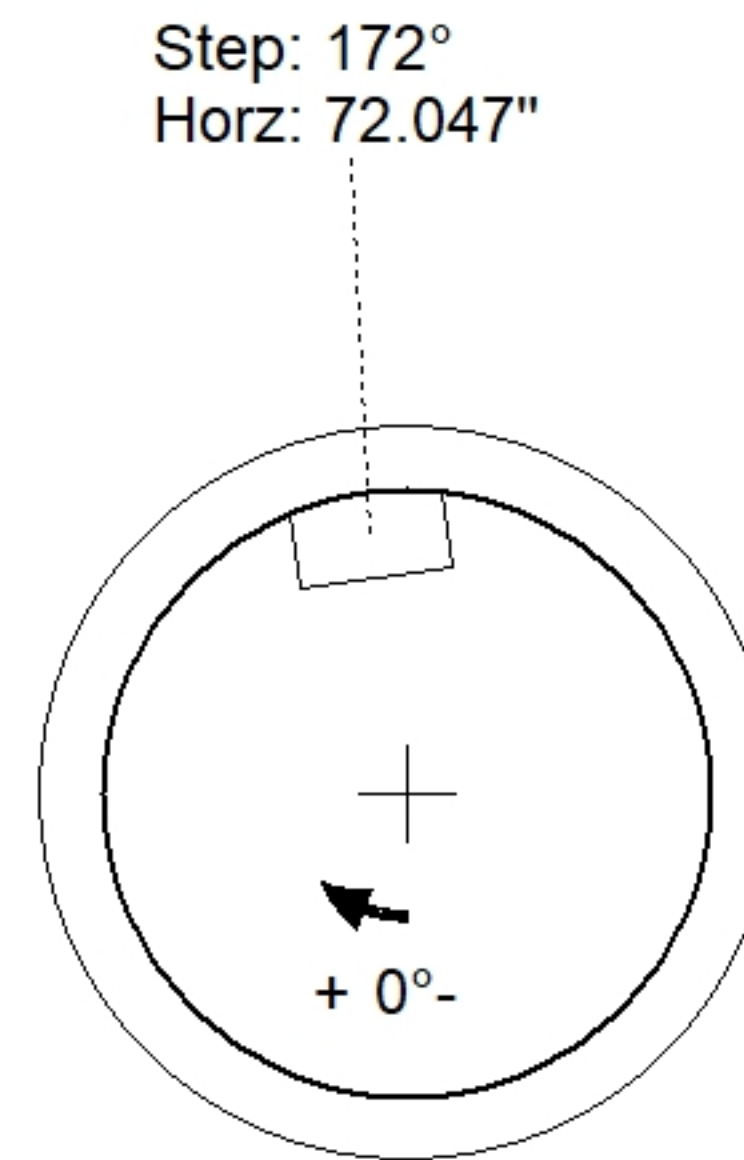
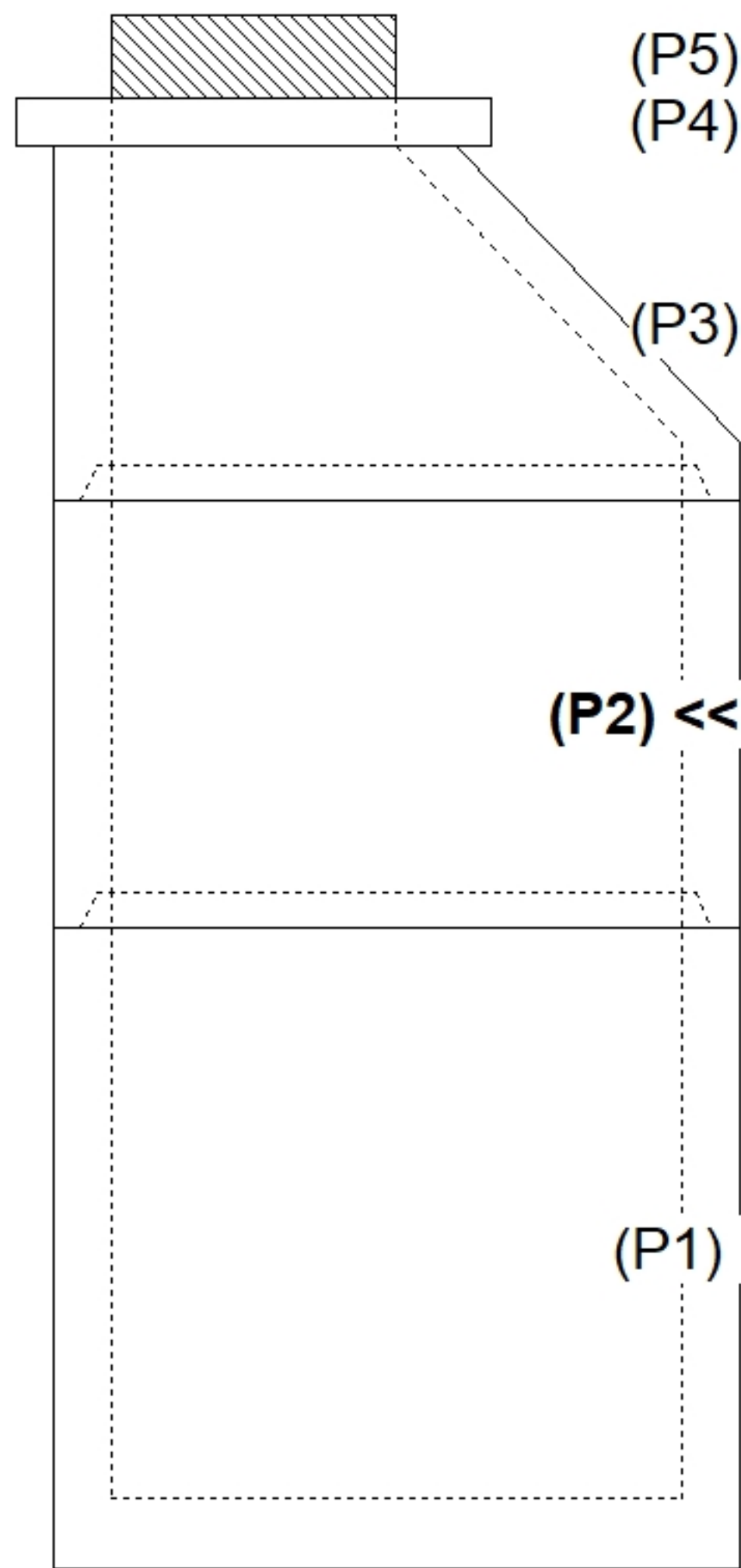

INSIDE WALL DIMENSIONS

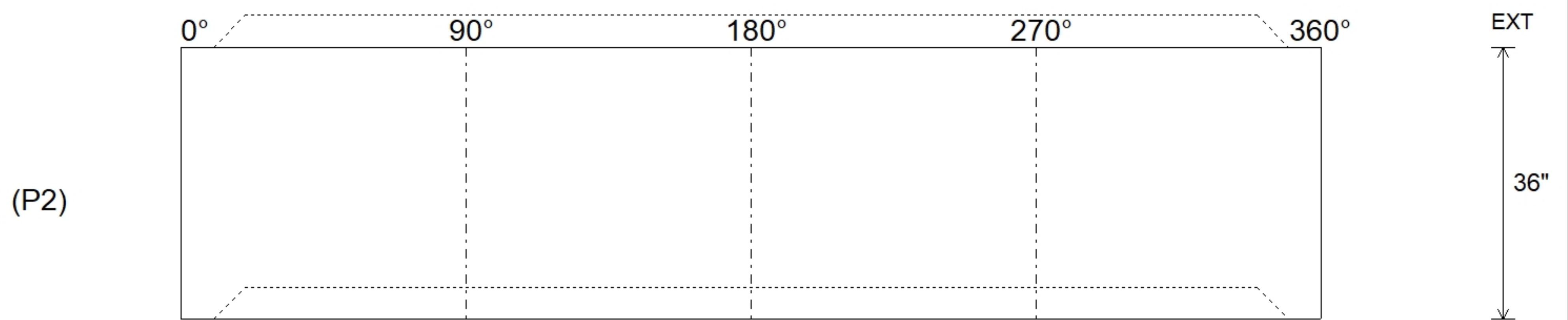

Coating (Int):	Seam Up: Tongue Seam Dn: Groove	Wall Thickness: 5" Floor Height: 0"	Height (Int): 36" Height (Ext): 36"
Coating (Ext):			Weight (Net): 2515 lb Volume (Net): 0.64cu.yd