

Job Name: 26-1222 Woodvale Subdivision Ph.120-211-300
 Job Location: Erlanger, KY
 Contractor: Mago Construction Co. LLC

Plant: 100

2/26/2026 8:59:07 AM

Tech: Jared - A

PC: Celina Goff



Structure ID: MH-311-23 SS-MH

P1 MH048BAVF

MH BASE (08"F) T/n

- P4) 24" - CASTING HEIGHT - 7"
- P3) 48" - CON CONE w/24" HOLE F/G - 36"
- P2) 48" - MH RISER T/G - 48"
- P1) 48" - MH BASE (08"F) T/n - 27"
- 1) 48" - MH INVERT CHANNEL - FULL HEIGHT
- 1) CASTING - HOE MC-375 F/C Sanitary
- 2) 48" - Conseal CS-102 1.00" (Double)
- 1) PSX - 12-08 DD
- 8) MH Step ML-10-TDS-NCR - 10"

0 lb
 2252 lb
 3353 lb
 3612 lb
 1440 lb
 271 lb
 0 lb
 8 lb
 0 lb

 Structure Total: 10936 lb

Structure Notes:
 PLAN LABEL: 311
 1. HOE MC-375 F/C SANITARY PROVIDED BY ICAST.
 2. PER ASTM C76 SPECIFICATIONS.
 3. CONCRETE = 4,000 PSI AT 28 DAYS.
 4. REINFORCING PER ASTM A615 (GRADE 60).
 - CONE (As .12)
 - BASE WALL W/ DBL. AS 0.12
 - FLOOR (AS .40)

Rim: 896.5' Rim to Invert: 9.74' Slack: 0.88" Sump: 2" Step Position: 90

Position	Elev	Angle	Ext. (cw)	Pipe	Pipe OD	Connector	Hole	Horz Size	Up ()	Offset
Invert 1	886.76'	0°	0"	8" PVC SDR35	8.5"	PSX 12-08 DD	12"	12.129"	0"	0"
Invert 2										
Invert 3										
Invert 4										
Invert 5										
Invert 6										
Invert 7										
Invert 8										

RIGHT-SIDE UP VIEW (int. dimensions)

UPSIDE-DOWN VIEW (int. dimensions)

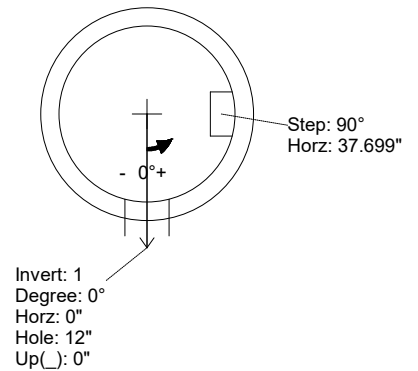
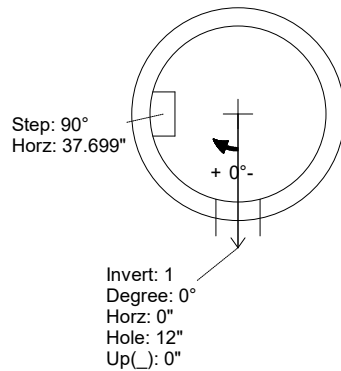
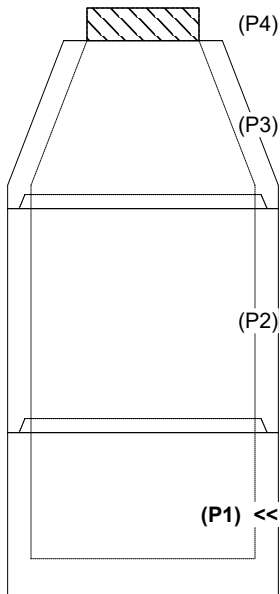

INSIDE WALL DIMENSIONS

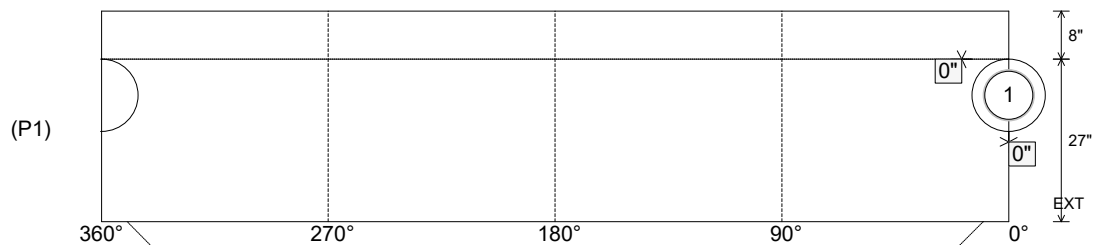

Coating (Int):
 Coating (Ext):

Seam Up: Tongue
 Seam Dn: n/a

Wall Thickness: 5"
 Floor Height: 8"

Height (Int): 27"
 Height (Ext): 35"

Weight (Net): 3612 lb
 Volume (Net): 0.92cu.yd

Job Name: 26-1222 Woodvale Subdivision Ph.120-211-300
 Job Location: Erlanger, KY
 Contractor: Mago Construction Co. LLC

Plant: 100

2/26/2026 8:59:07 AM

Tech: Jared - A

PC: Celina Goff



Structure ID: MH-311-23 SS-MH

P1 MH048BAVF

MH BASE (08"F) T/n

- P4) 24" - CASTING HEIGHT - 7"
- P3) 48" - CON CONE w/24" HOLE F/G - 36"
- P2) 48" - MH RISER T/G - 48"
- P1) 48" - MH BASE (08"F) T/n - 27"
- 1) 48" - MH INVERT CHANNEL - FULL HEIGHT
- 1) CASTING - HOE MC-375 F/C Sanitary
- 2) 48" - Conseal CS-102 1.00" (Double)
- 1) PSX - 12-08 DD
- 8) MH Step ML-10-TDS-NCR - 10"

0 lb
 2252 lb
 3353 lb
 3612 lb
 1440 lb
 271 lb
 0 lb
 8 lb
 0 lb

 Structure Total: 10936 lb

Structure Notes:

PLAN LABEL: 311

1. HOE MC-375 F/C SANITARY PROVIDED BY ICAST.
 2. PER ASTM C76 SPECIFICATIONS.
 3. CONCRETE = 4,000 PSI AT 28 DAYS.
 4. REINFORCING PER ASTM A615 (GRADE 60).
- CONE (As .12)
 - BASE WALL W/ DBL. AS 0.12
 - FLOOR (AS .40)

**Invert channel drawing
 Full height invert**

Rim: 896.5' Rim to Invert: 9.74' Slack: 0.88" Sump: 2" Step Position: 90

Position	Elev	Angle	Ext. (cw)	Pipe	Pipe OD	Connector	Hole	Horz Size	Up (↓)	Offset
Invert 1	886.76'	0°	0"	8" PVC SDR35	8.5"	PSX 12-08 DD	12"	12.129"	0"	0"
Invert 2										
Invert 3										
Invert 4										
Invert 5										
Invert 6										
Invert 7										
Invert 8										

RIGHT-SIDE UP VIEW (int. dimensions)

UPSIDE-DOWN VIEW (int. dimensions)

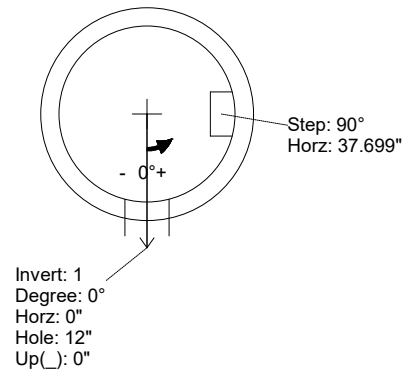
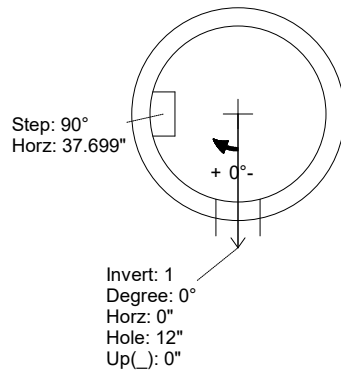
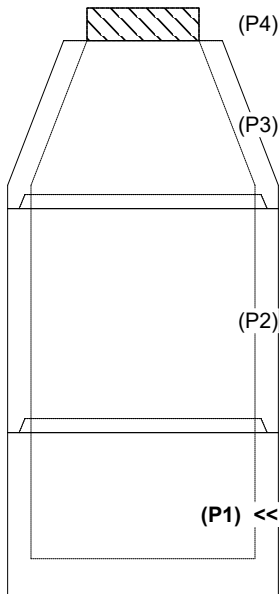

INSIDE WALL DIMENSIONS

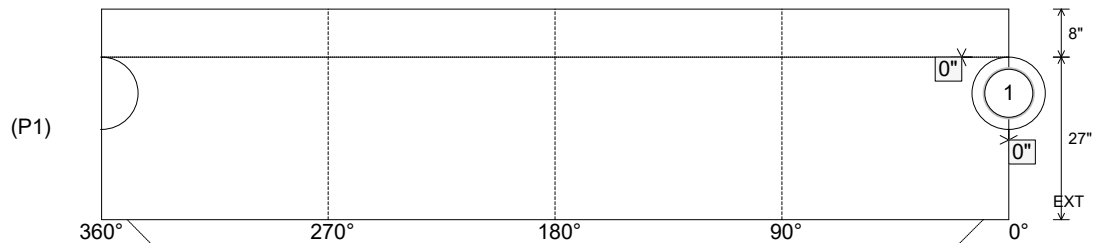

Coating (Int):
 Coating (Ext):

Seam Up: Tongue
 Seam Dn: n/a

Wall Thickness: 5"
 Floor Height: 8"

Height (Int): 27"
 Height (Ext): 35"

Weight (Net): 3612 lb
 Volume (Net): 0.92cu.yd