

**Structure ID: MH-309-25 SS-MH**

**P3 MH048RS48**

**MH RISER T/G**

P5) 24" - CASTING HEIGHT - 7" P4) 48" - CON CONE w/24" HOLE F/G - 24" P3) 48" - MH RISER T/G - 48" P2) 48" - MH RISER T/G - 60" P1) 48" - MH BASE (08"F) T/n - 28" 1) 48" - MH INVERT CHANNEL - FULL HEIGHT 1) CASTING - HOE MC-375 F/C Sanitary 3) 48" - Conseal CS-102 1.00" (Double) 1) PSX - 12-08 DD 13) MH Step ML-10-TDS-NCR - 10"	0 lb 2252 lb 3353 lb 4192 lb 3682 lb 1440 lb 271 lb 0 lb 8 lb 0 lb ----- Structure Total: 15198 lb
--	---

Structure Notes:  
 PLAN LABEL: 309  
 1. HOE MC-375 F/C SANITARY PROVIDED BY ICAST.  
 2. PER ASTM C76 SPECIFICATIONS.  
 3. CONCRETE = 4,000 PSI AT 28 DAYS.  
 4. REINFORCING PER ASTM A615 (GRADE 60).  
 - CONE (As .12)  
 - BASE WALL W/ DBL. AS 0.12  
 - FLOOR (AS .40)

Rim: 900.5'    Rim to Invert: 13.82'    Slack: 0.84"    Sump: 2"    Step Position: 270

Position	Elev	Angle	Ext. (cw)	Pipe	Pipe OD	Connector	Hole	Horz Size	Up ( )	Offset
Invert 1										
Invert 2										
Invert 3										
Invert 4										
Invert 5										
Invert 6										
Invert 7										
Invert 8										

**RIGHT-SIDE UP VIEW (int. dimensions)**

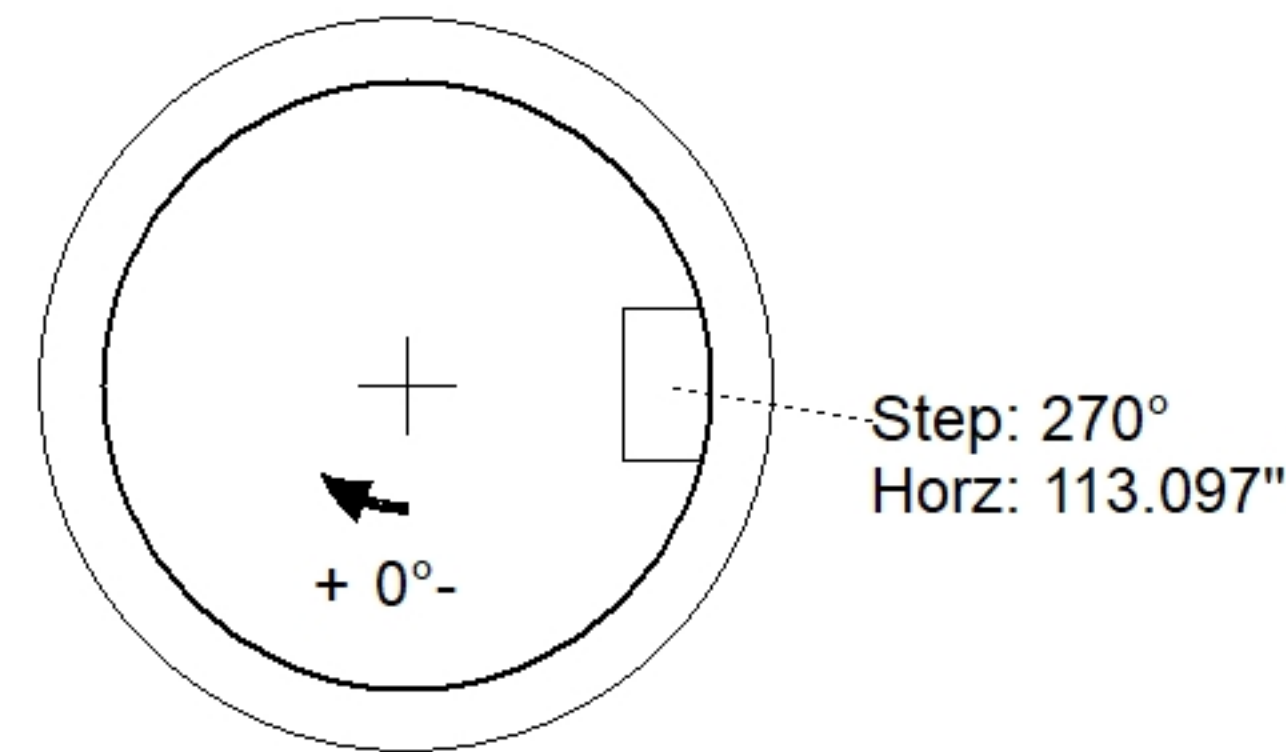
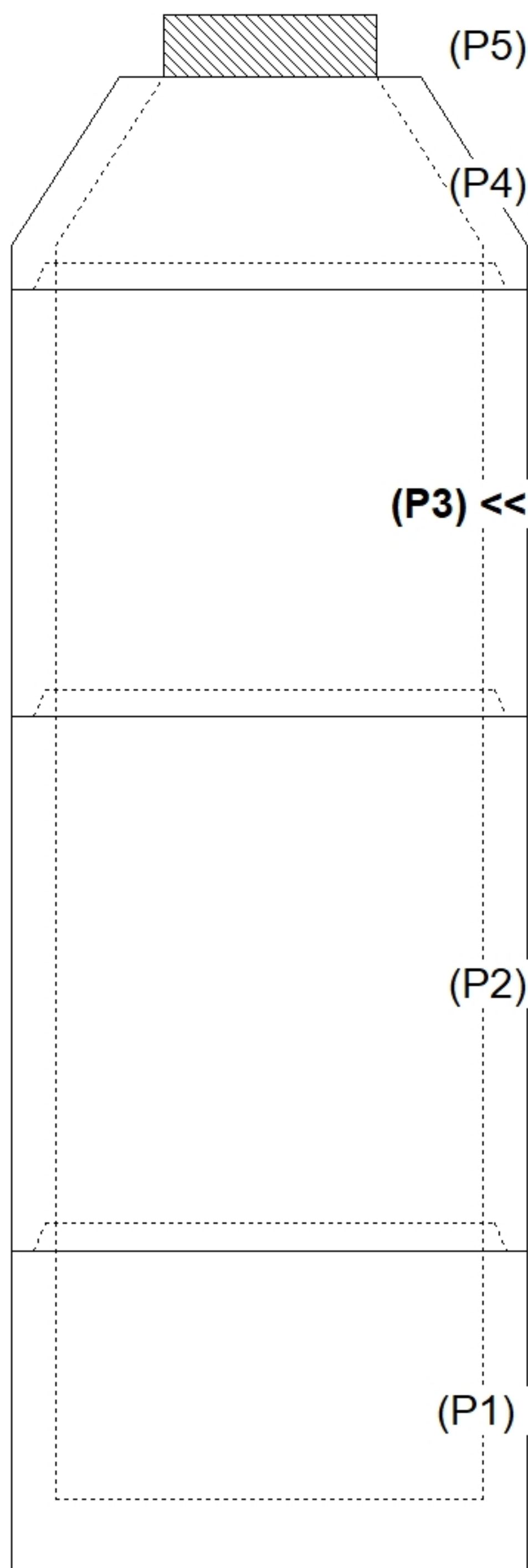

**INSIDE WALL DIMENSIONS**

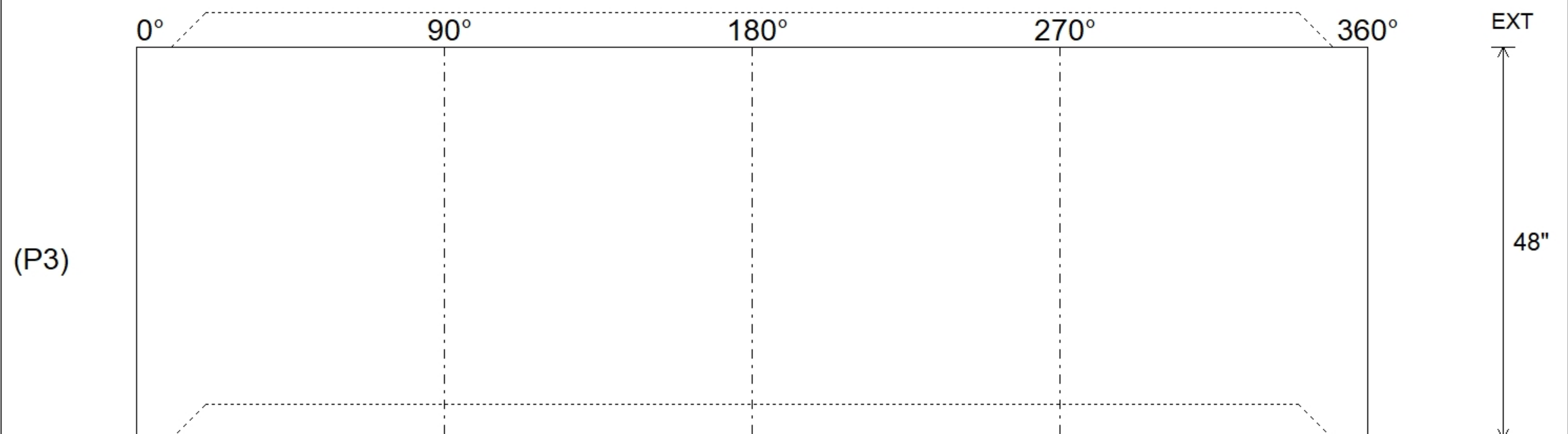

Coating (Int): Coating (Ext):	Seam Up: Tongue Seam Dn: Groove	Wall Thickness: 5" Floor Height: 0"	Height (Int): 48" Height (Ext): 48"	Weight (Net): 3353 lb Volume (Net): 0.86cu.yd
----------------------------------	------------------------------------	--	--	--