

Job Name: 26-1222 Woodvale Subdivision Ph.120-211-300
 Job Location: Erlanger, KY
 Contractor: Mago Construction Co. LLC

Plant: 100

2/27/2026 12:41:30 PM

Tech: Jared - A

PC: Celina Goff



Structure ID: MH-100-28 SS-MH

P1 MH048BA36

MH BASE (08"F) T/n

- P4) 24" - CASTING HEIGHT - 7"
- P3) 24" - GRADE RING F/F - 6"
- P2) 48" - CON CONE w/24" HOLE F/G - 36"
- P1) 48" - MH BASE (08"F) T/n - 36"
- 1) 48" - MH INVERT CHANNEL - FULL HEIGHT
- 1) CASTING - HOE MC-375 F/C Sanitary
- 1) 48" - Conseal CS-102 1.00" (Double)
- 2) PSX - 16Y DD
- 3) Z-Lok - C107-1
- 5) MH Step ML-10-TDS-NCR - 10"

0 lb
 405 lb
 2252 lb
 4089 lb
 1440 lb
 271 lb
 0 lb
 15 lb
 3 lb
 0 lb

 Structure Total: 8476 lb

Structure Notes:
 PLAN LABEL: 100
 1. HOE MC-375 F/C SANITARY PROVIDED BY ICAST.
 2. PER ASTM C478 SPECIFICATIONS.
 3. CONCRETE = 4,000 PSI AT 28 DAYS.
 4. REINFORCING PER ASTM A615 (GRADE 60).
 - CONE (As .12)
 - BASE WALL W/ DBL. AS 0.12
 - FLOOR (AS .40)

Extra steel required between inv's 1, 2, & 3

Rim: 848.94' Rim to Invert: 6.99' Slack: 1.88" Sump: 3" Step Position: 175.5"

Position	Elev	Angle	Ext. (cw)	Pipe	Pipe OD	Connector	Hole	Horz Size	Up ()	Offset
Invert 1	841.95'	0°	0"	10" PVC SDR35	10.5"	PSX 16Y DD	16"	16.312"	0"	0"
Invert 2	842.05'	256°	129.573"	10" PVC SDR35	10.5"	PSX 16Y DD	16"	16.312"	1.2"	0"
Invert 3	842.25'	95°	48.084"	1.25" PVC SDR11	1.66"	Z-Lok C107-1	5"	5.009"	4.779"	0"
Invert 4	842.25'	95°	62.126"	1.25" PVC SDR11	1.66"	Z-Lok C107-1	5"	6.087"	4.779"	13.5"
Invert 5	842.25'	95°	34.041"	1.25" PVC SDR11	1.66"	Z-Lok C107-1	5"	6.087"	4.779"	-13.5"
Invert 6										
Invert 7										
Invert 8										

RIGHT-SIDE UP VIEW (int. dimensions)

UPSIDE-DOWN VIEW (int. dimensions)

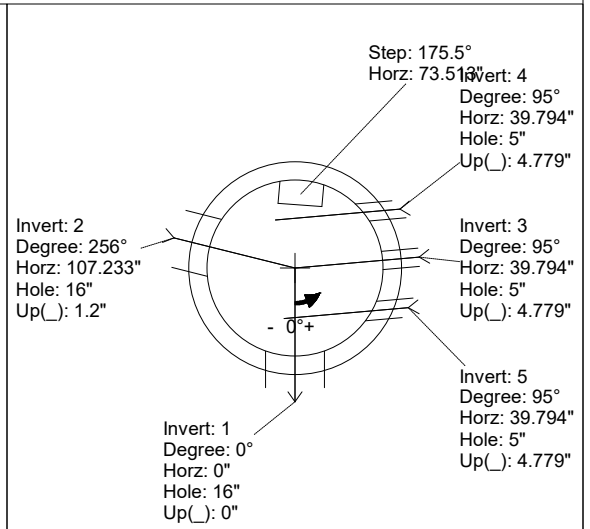
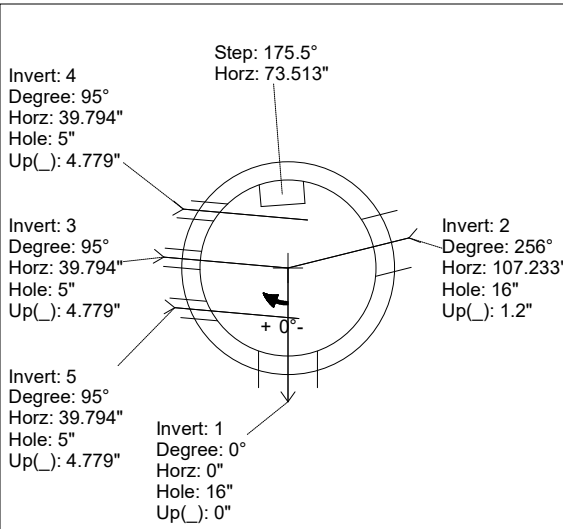
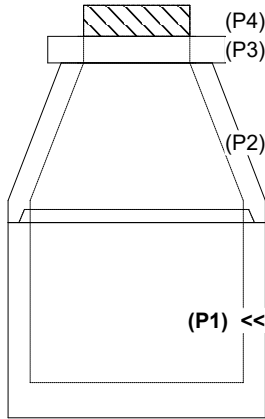

INSIDE WALL DIMENSIONS

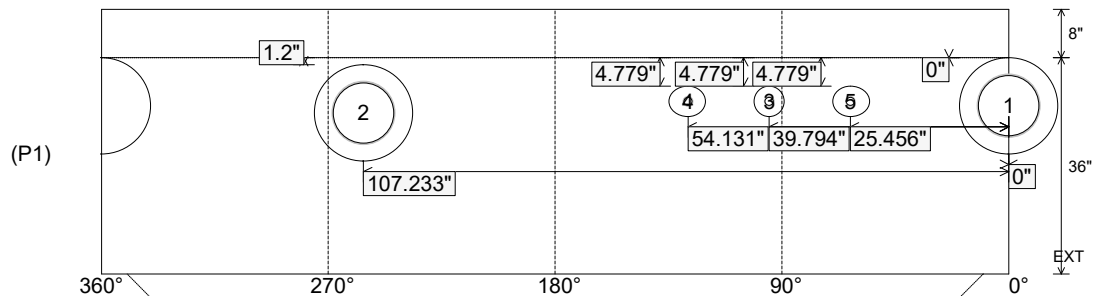

Coating (Int):
 Coating (Ext):

Seam Up: Tongue
 Seam Dn: n/a

Wall Thickness: 5"
 Floor Height: 8"

Height (Int): 36"
 Height (Ext): 44"

Weight (Net): 4089 lb
 Volume (Net): 1.04cu.yd

Job Name: 26-1222 Woodvale Subdivision Ph.120-211-300
 Job Location: Erlanger, KY
 Contractor: Mago Construction Co. LLC

Plant: 100

2/27/2026 12:41:30 PM

Tech: Jared - A

PC: Celina Goff



Structure ID: MH-100-28 SS-MH

P1 MH048BA36

MH BASE (08"F) T/n

- P4) 24" - CASTING HEIGHT - 7"
- P3) 24" - GRADE RING F/F - 6"
- P2) 48" - CON CONE w/24" HOLE F/G - 36"
- P1) 48" - MH BASE (08"F) T/n - 36"
- 1) 48" - MH INVERT CHANNEL - FULL HEIGHT
- 1) CASTING - HOE MC-375 F/C Sanitary
- 1) 48" - Conseal CS-102 1.00" (Double)
- 2) PSX - 16Y DD
- 3) Z-Lok - C107-1
- 5) MH Step ML-10-TDS-NCR - 10"

0 lb
 405 lb
 2252 lb
 4089 lb
 1440 lb
 271 lb
 0 lb
 15 lb
 3 lb
 0 lb

 Structure Total: 8476 lb

Structure Notes:

PLAN LABEL: 100

1. HOE MC-375 F/C SANITARY PROVIDED BY ICAST.
 2. PER ASTM C478 SPECIFICATIONS.
 3. CONCRETE = 4,000 PSI AT 28 DAYS.
 4. REINFORCING PER ASTM A615 (GRADE 60).
- CONE (As .12)
 - BASE WALL W/ DBL. AS 0.12
 - FLOOR (AS .40)

**Invert channel drawing
 Full height invert**

Rim: 848.94' Rim to Invert: 6.99' Slack: 1.88" Sump: 3" Step Position: 175.5"

Position	Elev	Angle	Ext. (cw)	Pipe	Pipe OD	Connector	Hole	Horz Size	Up ()	Offset
Invert 1	841.95'	0°	0"	10" PVC SDR35	10.5"	PSX 16Y DD	16"	16.312"	0"	0"
Invert 2	842.05'	256°	129.573"	10" PVC SDR35	10.5"	PSX 16Y DD	16"	16.312"	1.2"	0"
Invert 3	842.25'	95°	48.084"	1.25" PVC SDR11	1.66"	Z-Lok C107-1	5"	5.009"	4.779"	0"
Invert 4	842.25'	95°	62.126"	1.25" PVC SDR11	1.66"	Z-Lok C107-1	5"	6.087"	4.779"	13.5"
Invert 5	842.25'	95°	34.041"	1.25" PVC SDR11	1.66"	Z-Lok C107-1	5"	6.087"	4.779"	-13.5"
Invert 6										
Invert 7										
Invert 8										

RIGHT-SIDE UP VIEW (int. dimensions)

UPSIDE-DOWN VIEW (int. dimensions)

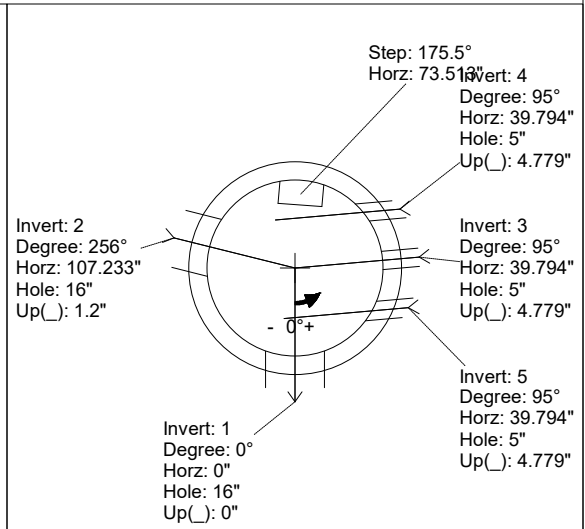
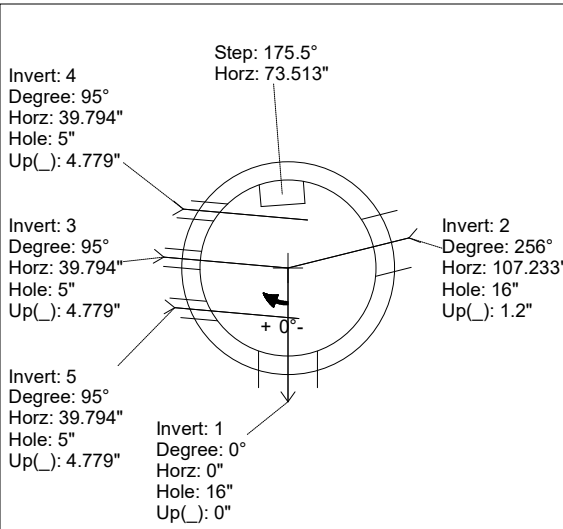
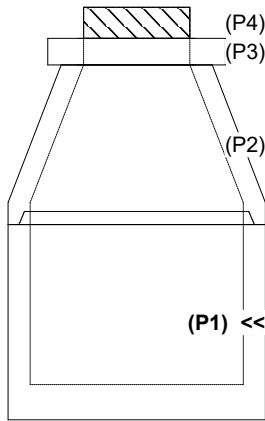

INSIDE WALL DIMENSIONS

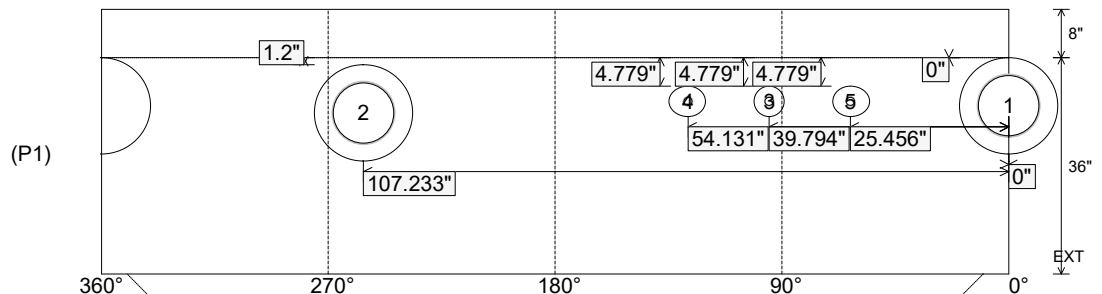

Coating (Int):
 Coating (Ext):

Seam Up: Tongue
 Seam Dn: n/a

Wall Thickness: 5"
 Floor Height: 8"

Height (Int): 36"
 Height (Ext): 44"

Weight (Net): 4089 lb
 Volume (Net): 1.04cu.yd