

Job Name: 26-1222 Woodvale Subdivision Ph.120-211-300
 Job Location: Erlanger, KY
 Contractor: Mago Construction Co. LLC

Plant: 100
 2/26/2026 9:01:23 AM

Tech: Jared - A
 PC: Celina Goff



Structure ID: CB-85-8 CB3A

P3 MH048LD12-24SQ

MH FLAT TOP w/24"x24" Hole F/G

- P4) 24" x 24" - CASTING HEIGHT - 3.50"
- P3) 48" - MH FLAT TOP w/24"x24" Hole F/G - 12"
- P2) 48" - MH RISER T/G - 36"
- P1) 48" - MH BASE T/n - 42"
- 1) CASTING - HOE 410 F/G
- 2) 48" - Conseal CS-102 1.00"
- 1) 24" x 24" - Conseal CS-102 1.00"
- 2) Hole - 24
- 1) Hole - 6
- 6) MH Step ML-10-TDS-NCR - 10"

0 lb
 1500 lb
 2503 lb
 3844 lb
 228 lb
 0 lb
 0 lb
 0 lb
 0 lb
 0 lb

 Structure Total: 8075 lb

- Structure Notes:**
 PLAN LABEL: 85
1. HOE 410 F/G PROVIDED BY ICAST.
 2. PER ASTM C478 SPECIFICATIONS.
 3. CONCRETE = 4,000 PSI AT 28 DAYS.
 4. REINFORCING PER ASTM A615 (GRADE 60).
 - TOP SLAB (As .62) #5 BARS AT 6" C.C.E.W.
 - RISER/WALLS (As .12)
 - FLOOR (As .31) #5 BARS AT 12" C.C.E.W.

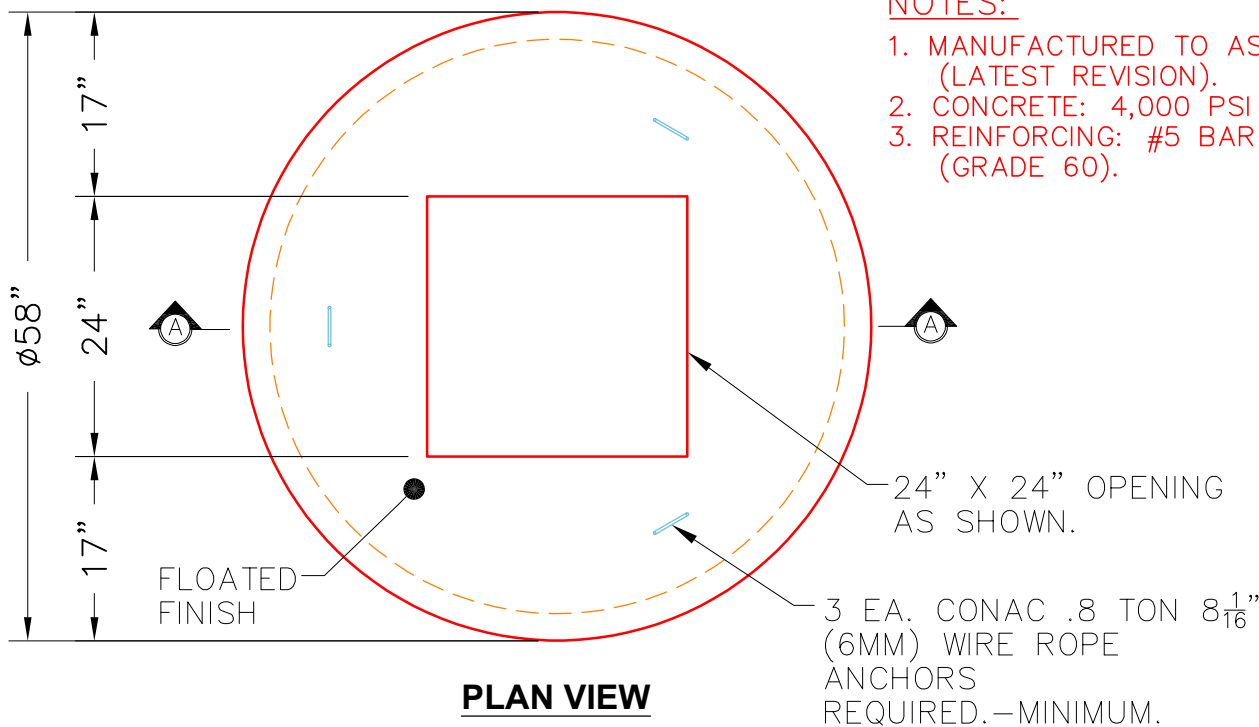

- NOTES:**
1. MANUFACTURED TO ASTM C-478 (LATEST REVISION).
 2. CONCRETE: 4,000 PSI AT 28 DAYS.
 3. REINFORCING: #5 BAR @ 6" O.C. E.W. (GRADE 60).

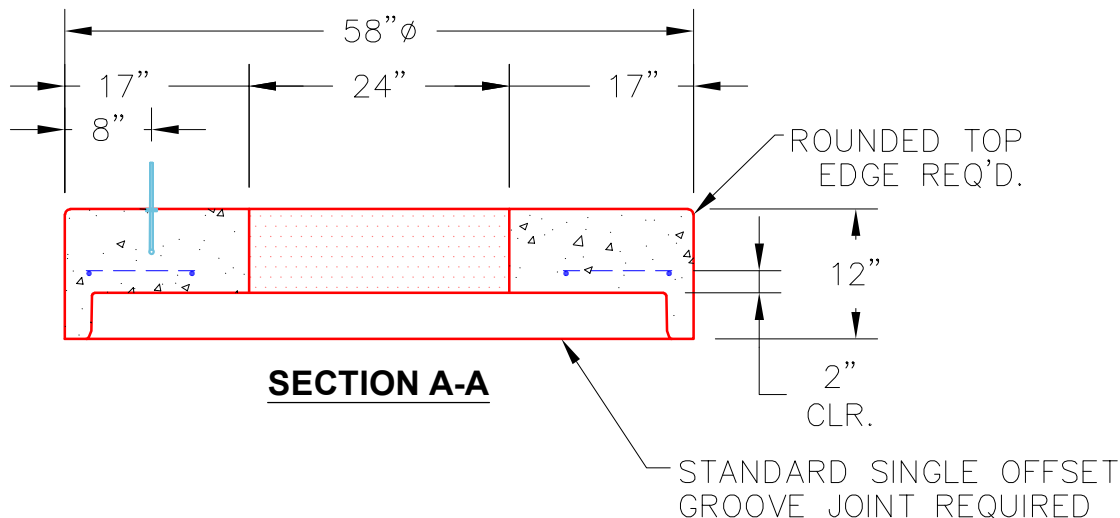

Coating (Int): Coating (Ext):	Seam Up: Flat Seam Dn: Groove	Wall Thickness: 5"	Height (Ext): 12"	Weight (Net): 1500 lb Volume (Net): 0.37cu.yd
----------------------------------	----------------------------------	--------------------	-------------------	--