

Job Name: 26-1222 Woodvale Subdivision Ph.120-211-300  
 Job Location: Erlanger, KY  
 Contractor: Mago Construction Co. LLC

Plant: 100  
 2/27/2026 12:41:24 PM

Tech: Jared - A  
 PC: Celina Goff



**Structure ID: CB-78-17 CB3**

**P1A BX2757-08BAVF**

**BOX BASE 8inW, 8inF, Variable Ht F/n**

- P2) 27" x 57" - CASTING HEIGHT - 5.50"
- P1) 27" x 57" - BOX BASE 8inW, 8inF, Variable Ht F/n - 71"
- 1) CASTING - EJ 7355 DBL SET (F/G/H)
- 1) 27" x 57" - Conseal CS-102 1.00"
- 2) Hole - 18
- 2) Hole - 6

0 lb  
 11260 lb  
 442 lb  
 0 lb  
 0 lb  
 0 lb  
 -----  
 Structure Total: 11702 lb

- Structure Notes:  
 PLAN LABEL: 78
1. EJ 7355 DBL SET (F/G/H) PROVIDED BY ICAST.
  2. PER ASTM C913 SPECIFICATIONS.
  3. CONCRETE = 4,000 PSI AT 28 DAYS.
  4. NO INVERT CHANNEL.
  5. REINFORCING PER ASTM A615 (GRADE 60).  
 - WALLS (As .12) #5 BARS AT 12" C.C.E.W.  
 - FLOOR (As .12) #5 BARS AT 12" C.C.E.W.

Rim: 897.41' Rim to Invert: 6.38' Slack: 0.06" Sump: 0" Step Position:

# First Pour Drawing

GENERAL NOTES:

1. MANUFACTURED TO ASTM C-913 (LATEST REVISION).
2. CONCRETE: 4,000 PSI AT 28 DAYS.
3. REINFORCING PER ATSM A615  
 WALLS: #5 BAR @ 12" E.W. C.C. (GRADE 60)  
 FLOOR: #5 BAR @ 12" E.W. C.C. (GRADE 60)
4. **WEIGHT: TOTAL = 11,260 LBS.**  
**FIRST POUR = 2,180 LBS.**  
 SECOND POUR= 9,080 LBS.

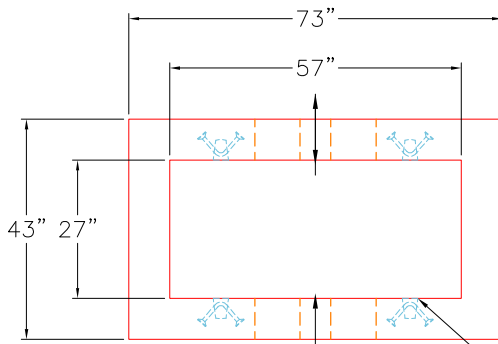

**TOP VIEW**

4 EA. CONAC 5CA14 ANCHORS FOR PLANT & FIELD HANDLING.

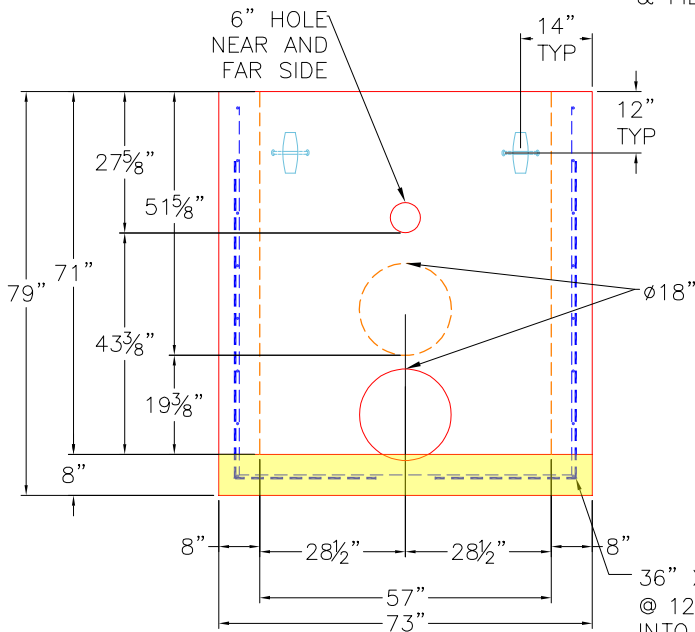

**FRONT VIEW**

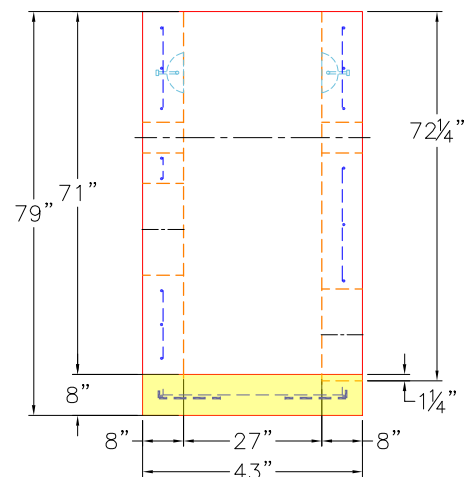

**RIGHT VIEW**

Coating (Int):  
 Coating (Ext):

Seam Up: Flat  
 Seam Dn: n/a

Wall Thickness: 8"  
 Floor Height: 8"

Height (Int): 71"  
 Height (Ext): 79"

Weight (Net): 11260 lb  
 Volume (Net): 2.88cu.yd

Job Name: 26-1222 Woodvale Subdivision Ph.120-211-300  
 Job Location: Erlanger, KY  
 Contractor: Mago Construction Co. LLC

Plant: 100  
 2/27/2026 12:41:24 PM

Tech: Jared - A  
 PC: Celina Goff



**Structure ID: CB-78-17 CB3**

**P1B BX2757-08BAVF**

**BOX BASE 8inW, 8inF, Variable Ht F/n**

- P2) 27" x 57" - CASTING HEIGHT - 5.50"
- P1) 27" x 57" - BOX BASE 8inW, 8inF, Variable Ht F/n - 71"
- 1) CASTING - EJ 7355 DBL SET (F/G/H)
- 1) 27" x 57" - Conseal CS-102 1.00"
- 2) Hole - 18
- 2) Hole - 6

0 lb  
 11260 lb  
 442 lb  
 0 lb  
 0 lb  
 0 lb  
 -----  
 Structure Total: 11702 lb

- Structure Notes:  
 PLAN LABEL: 78
1. EJ 7355 DBL SET (F/G/H) PROVIDED BY ICAST.
  2. PER ASTM C913 SPECIFICATIONS.
  3. CONCRETE = 4,000 PSI AT 28 DAYS.
  4. NO INVERT CHANNEL.
  5. REINFORCING PER ASTM A615 (GRADE 60).  
 - WALLS (As .12) #5 BARS AT 12" C.C.E.W.  
 - FLOOR (As .12) #5 BARS AT 12" C.C.E.W.

Rim: 897.41' Rim to Invert: 6.38' Slack: 0.06" Sump: 0" Step Position:

## Second Pour Drawing

GENERAL NOTES:

1. MANUFACTURED TO ASTM C-913 (LATEST REVISION).
2. CONCRETE: 4,000 PSI AT 28 DAYS.
3. REINFORCING PER ATSM A615  
 WALLS: #5 BAR @ 12" E.W. C.C. (GRADE 60)  
 FLOOR: #5 BAR @ 12" E.W. C.C. (GRADE 60)
4. **WEIGHT: TOTAL = 11,260 LBS.**  
**FIRST POUR = 2,180 LBS.**  
**SECOND POUR= 9,080 LBS.**

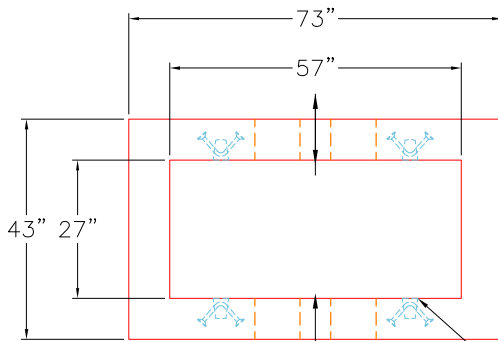

**TOP VIEW**

4 EA. CONAC 5CA14 ANCHORS FOR PLANT & FIELD HANDLING.

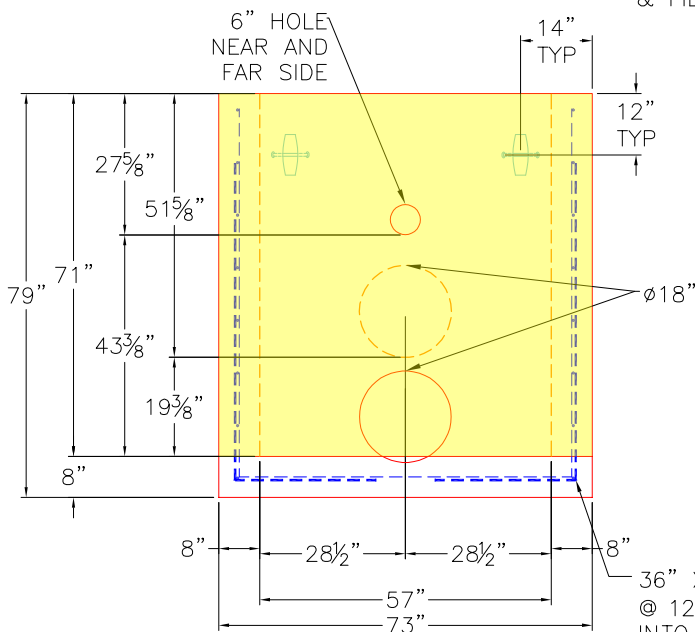

**FRONT VIEW**

36" X 36" #5 BAR @ 12" C.C. TIED INTO THE MAT

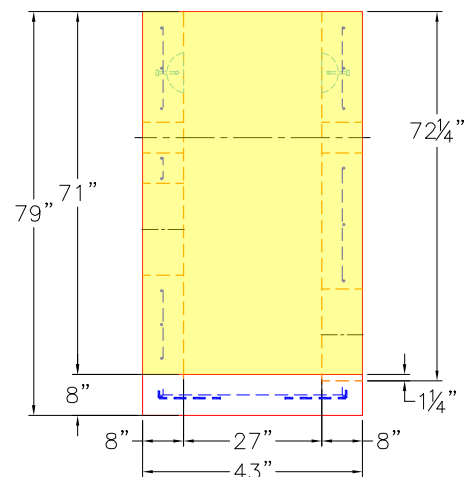

**RIGHT VIEW**

Coating (Int):  
 Coating (Ext):

Seam Up: Flat  
 Seam Dn: n/a

Wall Thickness: 8"  
 Floor Height: 8"

Height (Int): 71"  
 Height (Ext): 79"

Weight (Net): 11260 lb  
 Volume (Net): 2.88cu.yd