

Job Name: 26-1222 Woodvale Subdivision Ph.120-211-300
 Job Location: Erlanger, KY
 Contractor: Mago Construction Co. LLC

Plant: 100
 2/27/2026 12:41:47 PM

Tech: Jared - A
 PC: Celina Goff



Structure ID: CB-31-64 CB3A

P1A BX2757-08BAVF

BOX BASE 8inW, 8inF, Variable Ht F/n

- P2) 27" x 57" - CASTING HEIGHT - 5.50"
- P1) 27" x 57" - BOX BASE 8inW, 8inF, Variable Ht F/n - 68"
- 1) CASTING - EJ 7355 DBL SET (F/G/H)
- 1) 27" x 57" - Conseal CS-102 1.00"
- 1) Hole - 20
- 1) Hole - 6

0 lb
 11007 lb
 442 lb
 0 lb
 0 lb
 0 lb

 Structure Total: 11449 lb

- Structure Notes:
 PLAN LABEL: 31
1. EJ 7355 DBL SET (F/G/H) PROVIDED BY ICAST.
 2. PER ASTM C913 SPECIFICATIONS.
 3. CONCRETE = 4,000 PSI AT 28 DAYS.
 4. NO INVERT CHANNEL.
 5. REINFORCING PER ASTM A615 (GRADE 60).
 - WALLS (As .12) #5 BARS AT 12" C.C.E.W.
 - FLOOR (As .12) #5 BARS AT 12" C.C.E.W.

Rim: 843.53' Rim to Invert: 6.18' Slack: 0.66" Sump: 0" Step Position:

First Pour Drawing

GENERAL NOTES:

1. MANUFACTURED TO ASTM C-913 (LATEST REVISION).
2. CONCRETE: 4,000 PSI AT 28 DAYS.
3. REINFORCING PER ATSM A615
 WALLS: #5 BAR @ 12" E.W. C.C. (GRADE 60)
 FLOOR: #5 BAR @ 12" E.W. C.C. (GRADE 60)
4. **WEIGHT: TOTAL = 11,007 LBS.**
FIRST POUR = 2,180 LBS.
 SECOND POUR = 8,827 LBS.

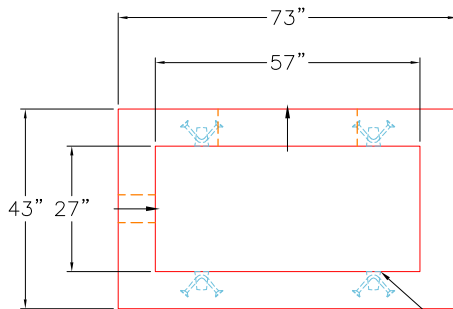

TOP VIEW

4 EA. CONAC 5CA14 ANCHORS FOR PLANT & FIELD HANDLING.

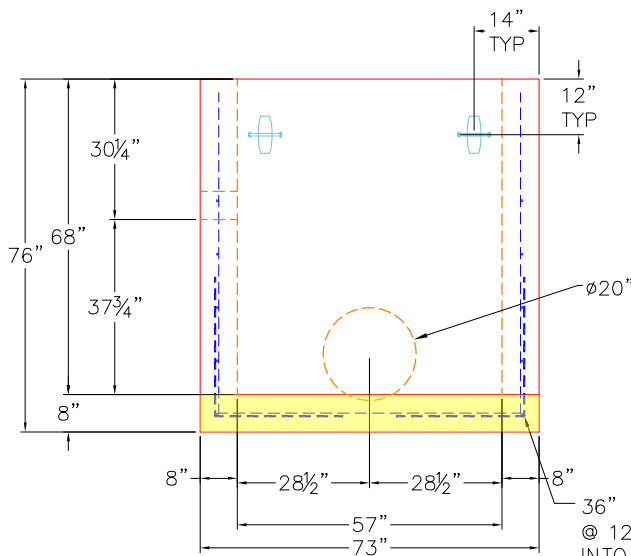

FRONT VIEW

36" X 36" #5 BAR @ 12" C.C. TIED INTO THE MAT

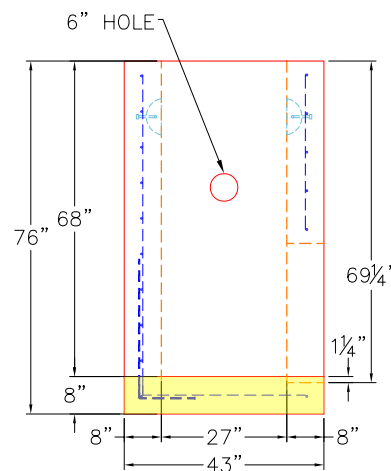

RIGHT VIEW

Coating (Int):
 Coating (Ext):

Seam Up: Flat
 Seam Dn: n/a

Wall Thickness: 8"
 Floor Height: 8"

Height (Int): 68"
 Height (Ext): 76"

Weight (Net): 11007 lb
 Volume (Net): 2.81cu.yd

Job Name: 26-1222 Woodvale Subdivision Ph.120-211-300
 Job Location: Erlanger, KY
 Contractor: Mago Construction Co. LLC

Plant: 100
 2/27/2026 12:41:47 PM

Tech: Jared - A
 PC: Celina Goff



Structure ID: CB-31-64 CB3A

P1B BX2757-08BAVF

BOX BASE 8inW, 8inF, Variable Ht F/n

- P2) 27" x 57" - CASTING HEIGHT - 5.50"
- P1) 27" x 57" - BOX BASE 8inW, 8inF, Variable Ht F/n - 68"
- 1) CASTING - EJ 7355 DBL SET (F/G/H)
- 1) 27" x 57" - Conseal CS-102 1.00"
- 1) Hole - 20
- 1) Hole - 6

0 lb
 11007 lb
 442 lb
 0 lb
 0 lb
 0 lb
 Structure Total: 11449 lb

- Structure Notes:
 PLAN LABEL: 31
1. EJ 7355 DBL SET (F/G/H) PROVIDED BY ICAST.
 2. PER ASTM C913 SPECIFICATIONS.
 3. CONCRETE = 4,000 PSI AT 28 DAYS.
 4. NO INVERT CHANNEL.
 5. REINFORCING PER ASTM A615 (GRADE 60).
 - WALLS (As .12) #5 BARS AT 12" C.C.E.W.
 - FLOOR (As .12) #5 BARS AT 12" C.C.E.W.

Rim: 843.53' Rim to Invert: 6.18' Slack: 0.66" Sump: 0" Step Position:

Second Pour Drawing

GENERAL NOTES:

1. MANUFACTURED TO ASTM C-913 (LATEST REVISION).
2. CONCRETE: 4,000 PSI AT 28 DAYS.
3. REINFORCING PER ATSM A615
 WALLS: #5 BAR @ 12" E.W. C.C. (GRADE 60)
 FLOOR: #5 BAR @ 12" E.W. C.C. (GRADE 60)
4. **WEIGHT: TOTAL = 11,007 LBS.**
FIRST POUR = 2,180 LBS.
SECOND POUR = 8,827 LBS.

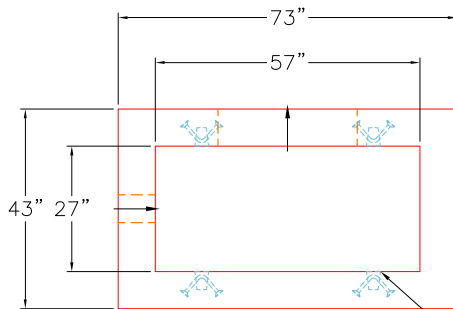

TOP VIEW

4 EA. CONAC 5CA14 ANCHORS FOR PLANT & FIELD HANDLING.

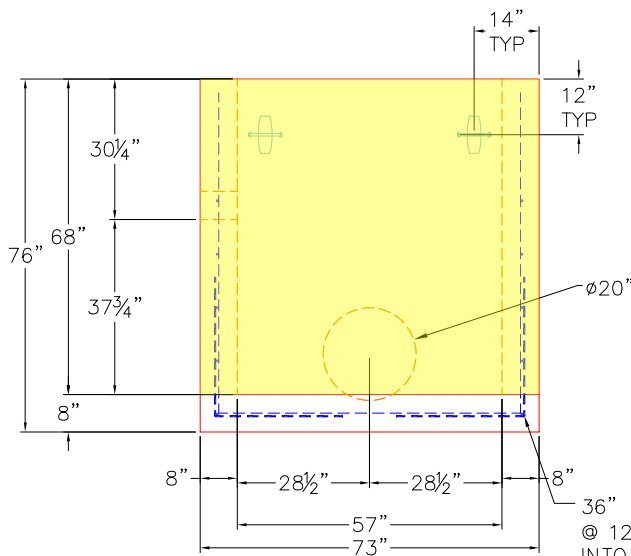

FRONT VIEW

36" X 36" #5 BAR @ 12" C.C. TIED INTO THE MAT

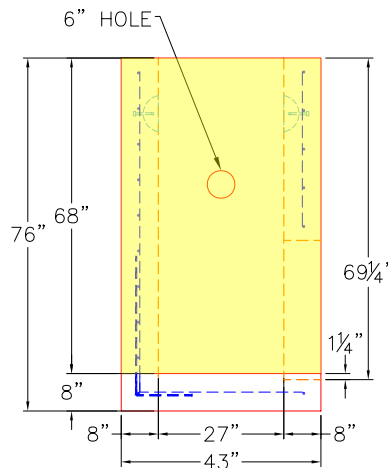

RIGHT VIEW

Coating (Int):
 Coating (Ext):

Seam Up: Flat
 Seam Dn: n/a

Wall Thickness: 8"
 Floor Height: 8"

Height (Int): 68"
 Height (Ext): 76"

Weight (Net): 11007 lb
 Volume (Net): 2.81cu.yd