

**Structure ID: CB-26-63 CB3A**

**P1 BX28280808VH**

**BOX BASE 8inW, 8inF, Variable Ht F/n**

|  |  |
|--|--|
| P2) 28" x 28" - CASTING HEIGHT - 5.50"<br>P1) 28" x 28" - BOX BASE 8inW, 8inF, Variable Ht F/n - 42"<br>1) CASTING - EJ 7350 SET (F/G/H)<br>1) 28" x 28" - Conseal CS-102 1.00"<br>1) Hole - 16<br>2) Hole - 6 | 0 lb<br>5187 lb<br>442 lb<br>0 lb<br>0 lb<br>0 lb<br>-----<br>Structure Total: 5629 lb |
|--|--|

**Structure Notes:**  
 PLAN LABEL: 26  
 1. EJ 7350 SET (F/G/H) PROVIDED BY ICAST.  
 2. PER ASTM C913 SPECIFICATIONS.  
 3. CONCRETE = 4,000 PSI AT 28 DAYS.  
 4. NO INVERT CHANNEL.  
 5. REINFORCING PER ASTM A615 (GRADE 60).  
 - WALLS (As .12) #5 BARS AT 12" C.C.E.W.  
 - FLOOR (As .12) #5 BARS AT 12" C.C.E.W.

Rim: 851.92'    Rim to Invert: 4'    Slack: 0.5"    Sump: 0"    Step Position:

| Position | Elev    | Angle | Ext. (cw) | Pipe                | Pipe OD | Connector | Hole | Horz Size | Up ( ) | Offset |
|----------|---------|-------|-----------|---------------------|---------|-----------|------|-----------|--------|--------|
| Invert 1 | 847.92' | 90°   | 22"       | 12" HDPE            | 14.5"   | Hole 16   | 16"  | 16"       | -1.25" | 0"     |
| Invert 2 | 848.92' | 90°   | 32"       | 4" HDPE (perf pipe) | 4.8"    | Hole 6    | 6"   | 6"        | 11.6"  | 10"    |
| Invert 3 | 848.92' | 270°  | 22"       | 4" HDPE (perf pipe) | 4.8"    | Hole 6    | 6"   | 6"        | 11.6"  | 0"     |
| Invert 4 |         |       |           |                     |         |           |      |           |        |        |
| Invert 5 |         |       |           |                     |         |           |      |           |        |        |
| Invert 6 |         |       |           |                     |         |           |      |           |        |        |
| Invert 7 |         |       |           |                     |         |           |      |           |        |        |
| Invert 8 |         |       |           |                     |         |           |      |           |        |        |

RIGHT-SIDE UP VIEW (int. dimensions)

UPSIDE-DOWN VIEW (int. dimensions)

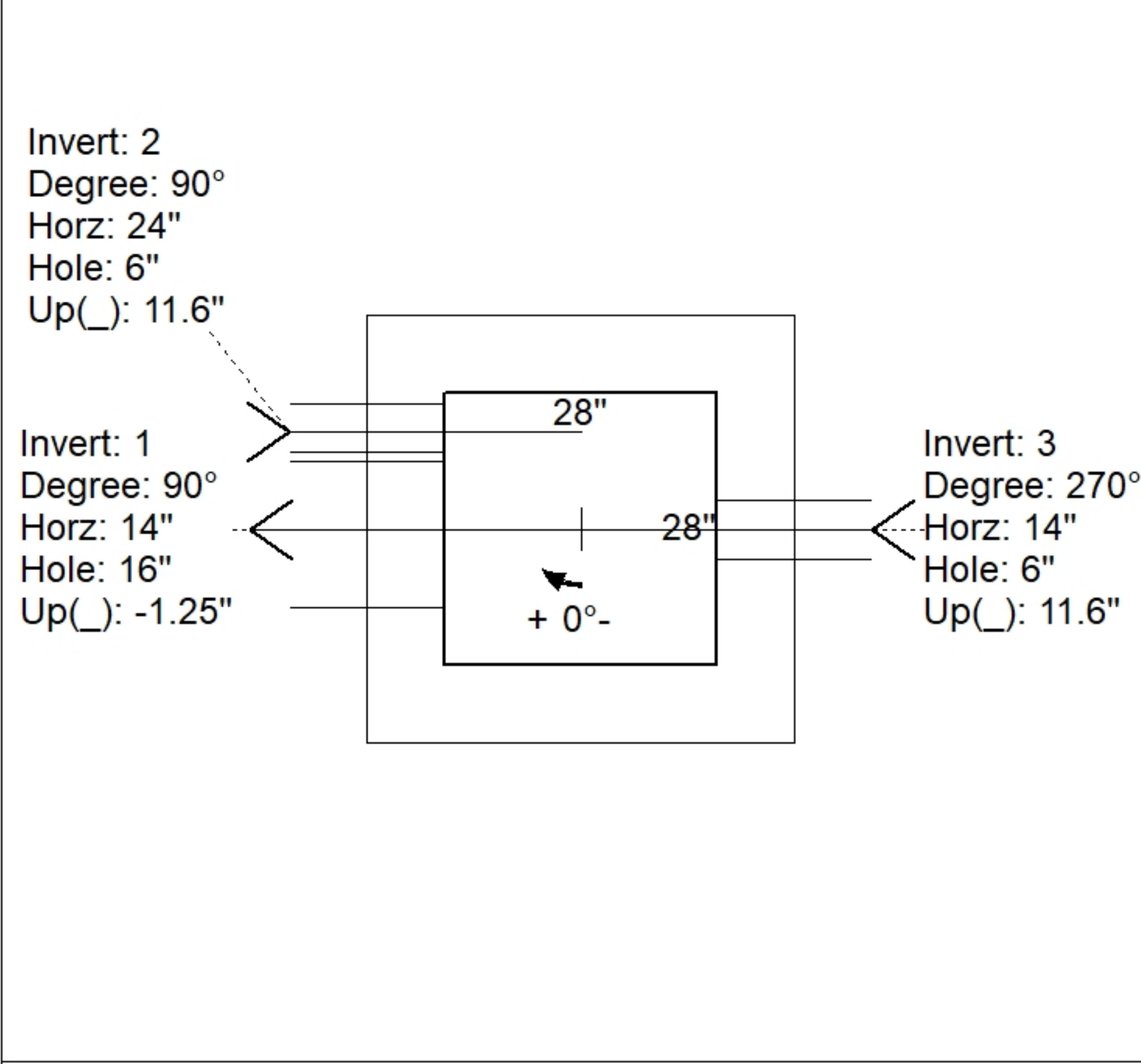
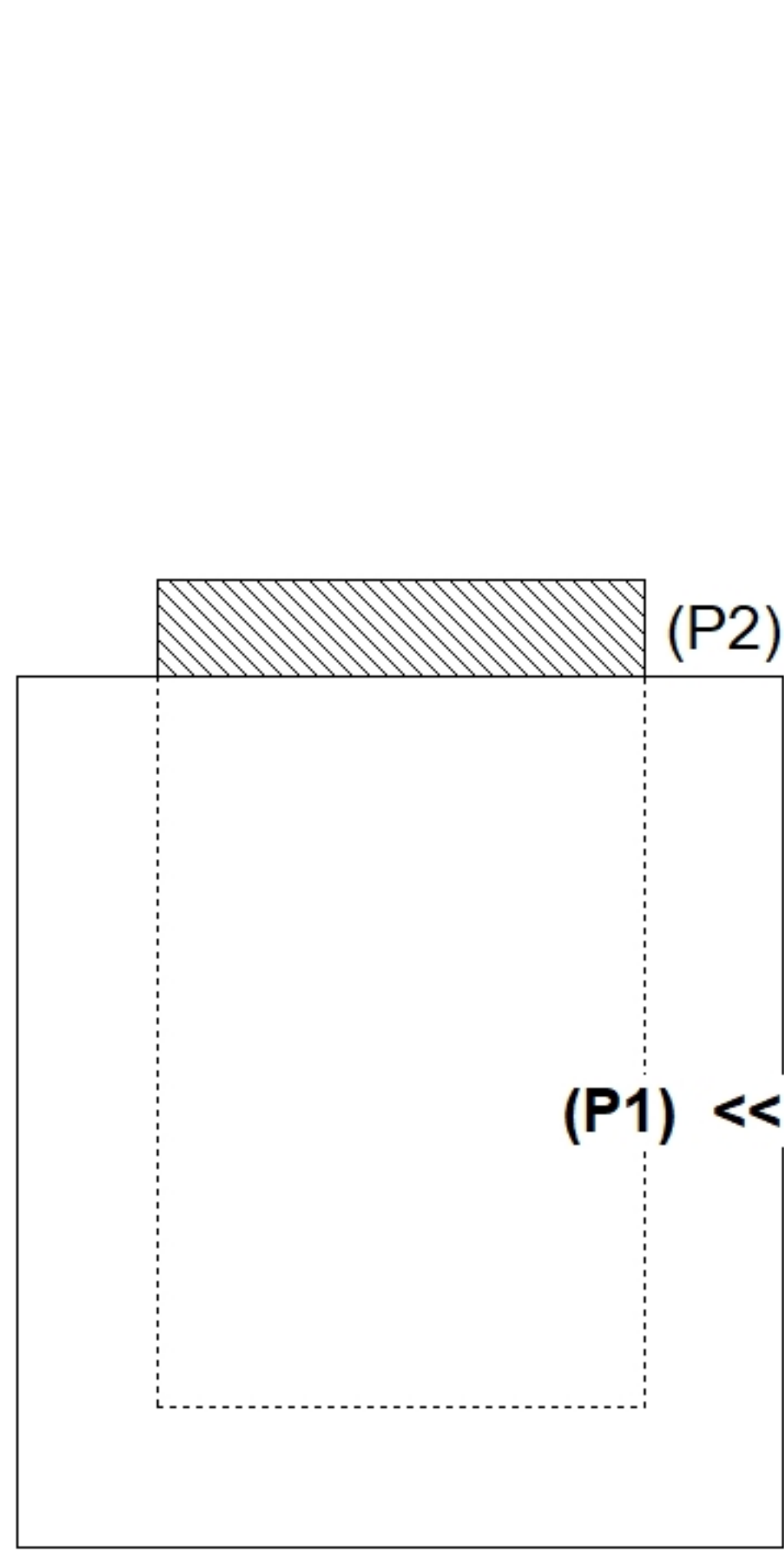

INSIDE WALL DIMENSIONS

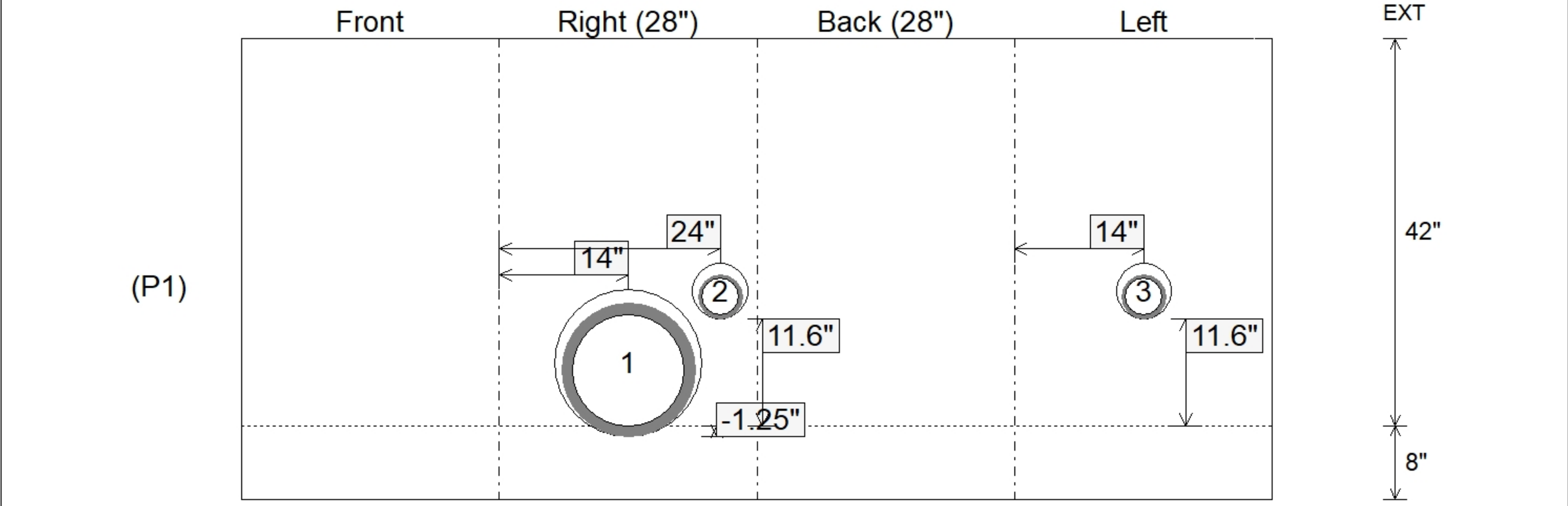

|                                  |                               |  |  |  |
|----------------------------------|-------------------------------|--|--|--|
| Coating (Int):<br>Coating (Ext): | Seam Up: Flat<br>Seam Dn: n/a | Wall Thickness: 8"<br>Floor Height: 8" | Height (Int): 42"<br>Height (Ext): 50" | Weight (Net): 5187 lb<br>Volume (Net): 1.32cu.yd |
|----------------------------------|-------------------------------|--|--|--|