

Job Name: 26-1210 Sacramento Gravity Sewer	Plant: Beaver Dam	Tech: S. Felletter	
Job Location: Sacramento, KY Contractor: Scott & Ritter, Inc.	4/24/2026 8:09:39 AM	PC: T. Lewis	

Structure ID: FMH1-42 SS-MH

P3 MH048CN30

ECC CONE w/ 24" HOLE F/G

P5) 24" - CASTING HEIGHT - 7"	0 lb
P4) 24" - GRADE RING F/F - 4"	270 lb
P3) 48" - ECC CONE w/ 24" HOLE F/G - 30"	2050 lb
P2) 48" - MH RISER T/G - 36"	2515 lb
P1) 48" - MH BASE T/n - 18"	2492 lb
1) JOINT WRAP - 0.065"x6"x50' CONSEAL CS212	0 lb
1) JOINT WRAP PRIMER - CONSEAL CS-75 (1 gal.)	0 lb
1) 48" - MH INVERT CHANNEL - FULL HEIGHT	1440 lb
2) 48" - Conseal CS-102 1.00" (Double)	0 lb
1) PSX - 12-08 DD (DBL Bands)	8 lb
1) PSX - 12-06 DD (DBL Bands)	8 lb
7) MH Step ML-10-TDS-NCR - 10"	0 lb
Structure Total:	8783 lb

Structure Notes:
 1. PER ASTM C478 SPECIFICATIONS.
 2. CONCRETE = 4,000 PSI AT 28 DAYS.
 3. CASTING BY OTHERS.

REINFORCING PER ASTM A615 (GRADE 60).
 - CONE (As .12)
 - RISER/WALLS (As .12)
 - FLOOR (As .31) #5 BARS AT 12" C.C.E.W.

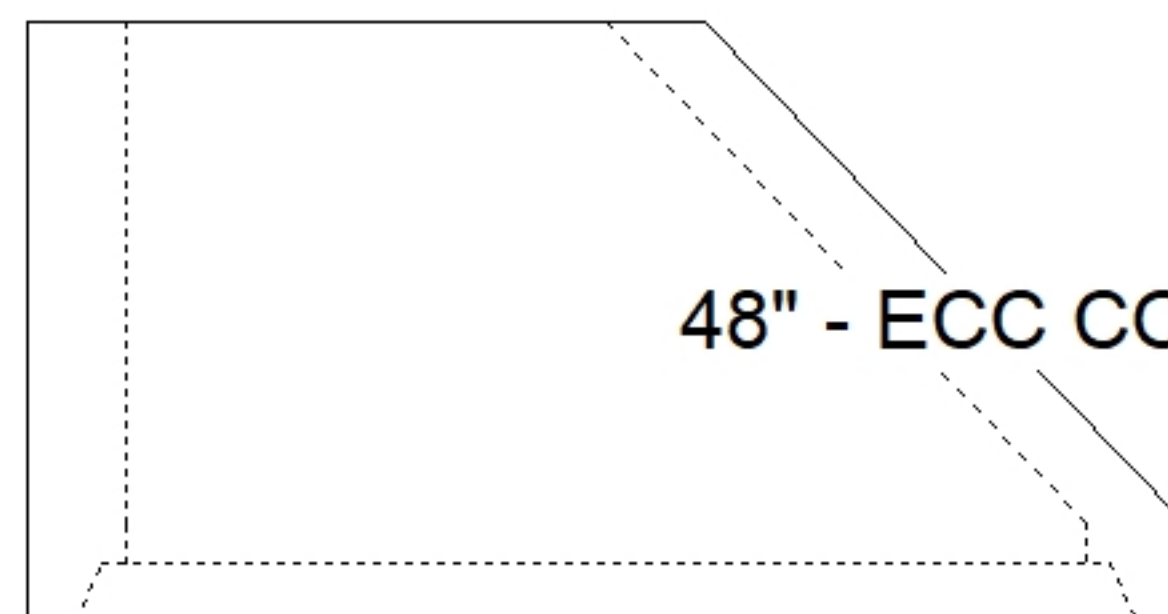
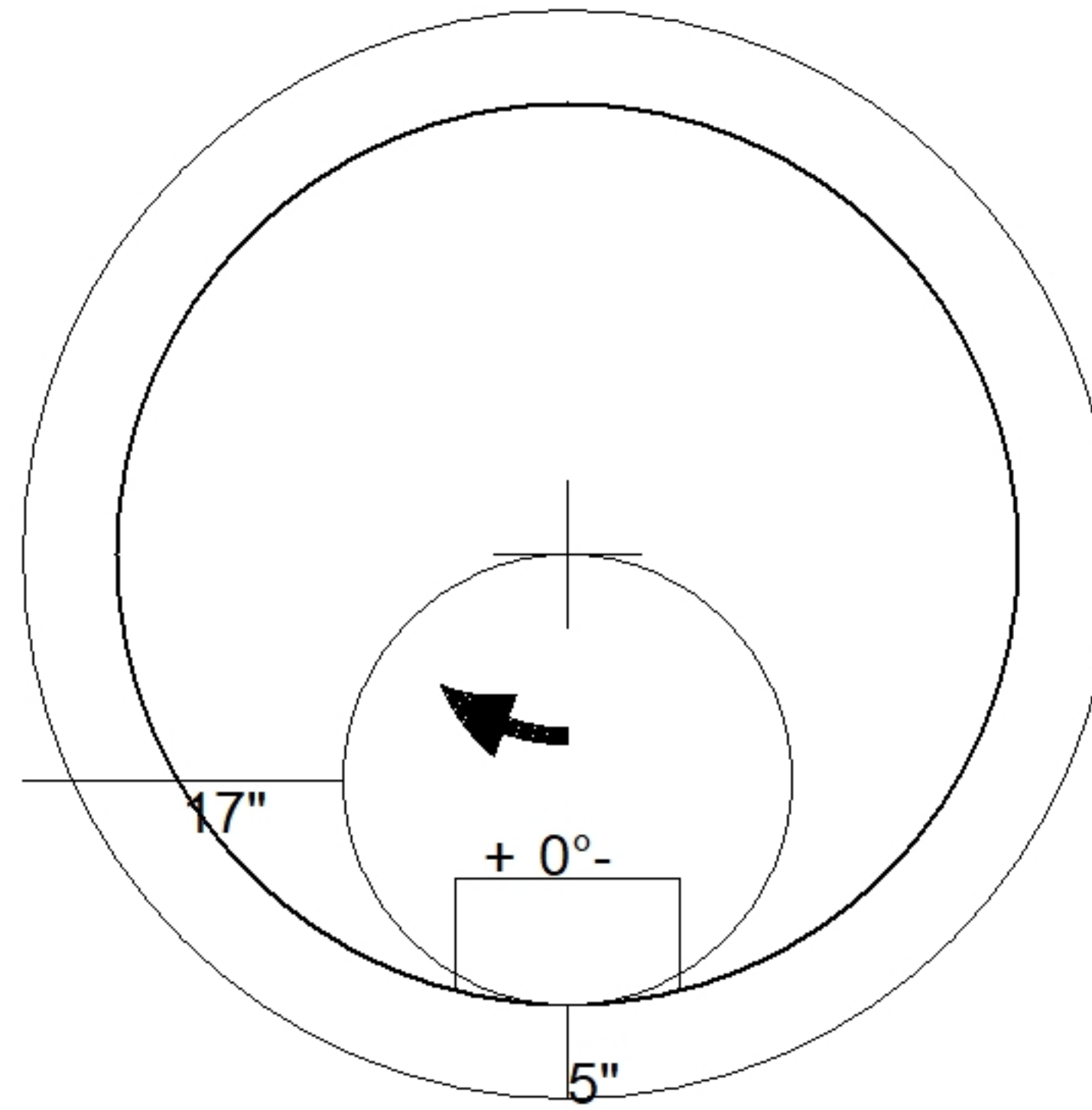

48" - ECC CONE w/ 24" HOLE F/G - 30" - (P3)

Coating (Int):	Seam Up: Flat	Wall Thickness: 5"	Height (Ext): 30"	Weight (Net): 2050 lb
Coating (Ext):	Seam Dn: Groove			Volume (Net): 0.41cu.yd