

Job Name: 26-1210 Sacramento Gravity Sewer
 Job Location: Sacramento, KY
 Contractor: Scott & Ritter, Inc.

Plant: Beaver Dam
 4/23/2026 8:35:52 AM

Tech: S. Felletter
 PC: T. Lewis



Structure ID: EMH2-40 SS-MH

P1 MH048BA24

MH BASE T/n

P3) 24" - CASTING HEIGHT - 7"	0 lb
P2) 48" - ECC CONE w/ 24" HOLE F/G - 36"	3000 lb
P1) 48" - MH BASE T/n - 24"	2938 lb
1) JOINT WRAP - 0.065"x6"x50' CONSEAL CS212	0 lb
1) JOINT WRAP PRIMER - CONSEAL CS-75 (1 gal.)	0 lb
1) 48" - MH INVERT CHANNEL - FULL HEIGHT	1440 lb
1) 48" - Conseal CS-102 1.00" (Double)	0 lb
1) PSX - 12-08 DD (DBL Bands)	8 lb
1) PSX - 8QRS DD (DBL Bands)	6 lb
4) MH Step ML-10-TDS-NCR - 10"	0 lb
Structure Total:	7392 lb

Structure Notes:
 1. PER ASTM C478 SPECIFICATIONS.
 2. CONCRETE = 4,000 PSI AT 28 DAYS.
 3. CASTING BY OTHERS.

REINFORCING PER ASTM A615 (GRADE 60).
 - CONE (As .12)
 - RISER/WALLS (As .12)
 - FLOOR (As .31) #5 BARS AT 12" C.C.E.W.

Rim: 487.72' Rim to Invert: 5.45' Slack: 0.4" Sump: 2" Step Position: 0°

Position	Elev	Angle	Ext. (cw)	Pipe	Pipe OD	Connector	Hole	Horz Size	Up ()	Offset
Invert 1	482.27'	0°	0"	8" PVC SDR35	8.5"	PSX 12-08 DD (DBL Bands)	12"	12.129"	0"	0"
Invert 2	482.37'	122°	61.75"	4" PVC SDR35	4.25"	PSX 8QRS DD (DBL Bands)	8"	8.038"	1.2"	0"
Invert 3										
Invert 4										
Invert 5										
Invert 6										
Invert 7										
Invert 8										

RIGHT-SIDE UP VIEW (int. dimensions)

UPSIDE-DOWN VIEW (int. dimensions)

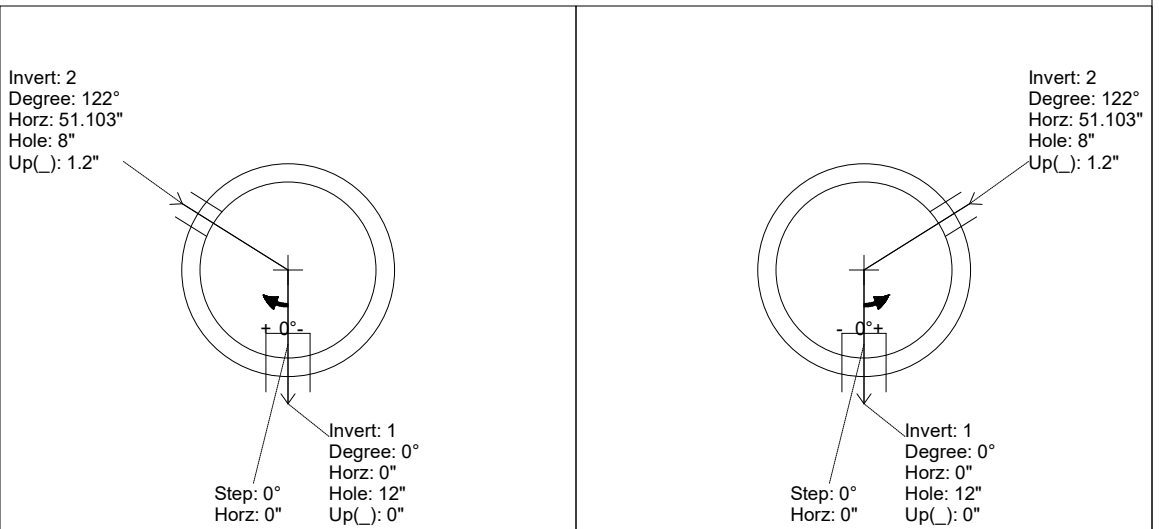

INSIDE WALL DIMENSIONS

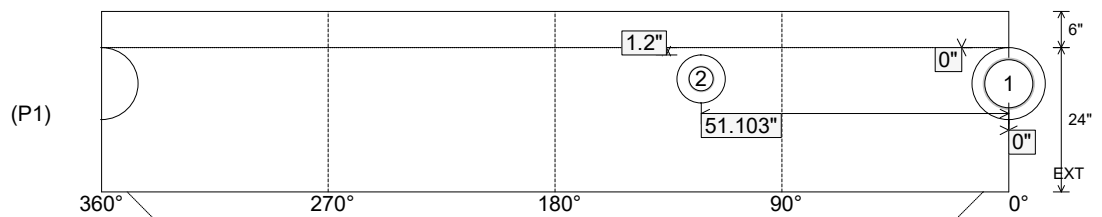

Coating (Int): Coating (Ext):	Seam Up: Tongue Seam Dn: n/a	Wall Thickness: 5" Floor Height: 6"	Height (Int): 24" Height (Ext): 30"	Weight (Net): 2938 lb Volume (Net): 0.75cu.yd
----------------------------------	---------------------------------	--	--	--

Job Name: 26-1210 Sacramento Gravity Sewer
 Job Location: Sacramento, KY
 Contractor: Scott & Ritter, Inc.

Plant: Beaver Dam
 4/23/2026 8:35:52 AM

Tech: S. Felletter
 PC: T. Lewis



Structure ID: EMH2-40 SS-MH

P1 MH048BA24

MH BASE T/n

- P3) 24" - CASTING HEIGHT - 7" 0 lb
 - P2) 48" - ECC CONE w/ 24" HOLE F/G - 36" 3000 lb
 - P1) 48" - MH BASE T/n - 24" 2938 lb
 - 1) JOINT WRAP - 0.065"x6"x50' CONSEAL CS212 0 lb
 - 1) JOINT WRAP PRIMER - CONSEAL CS-75 (1 gal.) 0 lb
 - 1) 48" - MH INVERT CHANNEL - FULL HEIGHT 1440 lb
 - 1) 48" - Conseal CS-102 1.00" (Double) 0 lb
 - 1) PSX - 12-08 DD (DBL Bands) 8 lb
 - 1) PSX - 8QRS DD (DBL Bands) 6 lb
 - 4) MH Step ML-10-TDS-NCR - 10" 0 lb
- Structure Total: 7392 lb

Structure Notes:
 1. PER ASTM C478 SPECIFICATIONS.
 2. CONCRETE = 4,000 PSI AT 28 DAYS.
 3. CASTING BY OTHERS.

REINFORCING PER ASTM A615 (GRADE 60).
 - CONE (As .12)
 - RISER/WALLS (As .12)
 - FLOOR (As .31) #5 BARS AT 12" C.C.E.W.

Invert channel drawing - full height invert

Rim: 487.72' Rim to Invert: 5.45' Slack: 0.4" Sump: 2" Step Position: 0°

Position	Elev	Angle	Ext. (cw)	Pipe	Pipe OD	Connector	Hole	Horz Size	Up ()	Offset
Invert 1	482.27'	0°	0"	8" PVC SDR35	8.5"	PSX 12-08 DD (DBL Bands)	12"	12.129"	0"	0"
Invert 2	482.37'	122°	61.75"	4" PVC SDR35	4.25"	PSX 8QRS DD (DBL Bands)	8"	8.038"	1.2"	0"
Invert 3										
Invert 4										
Invert 5										
Invert 6										
Invert 7										
Invert 8										

RIGHT-SIDE UP VIEW (int. dimensions)

UPSIDE-DOWN VIEW (int. dimensions)

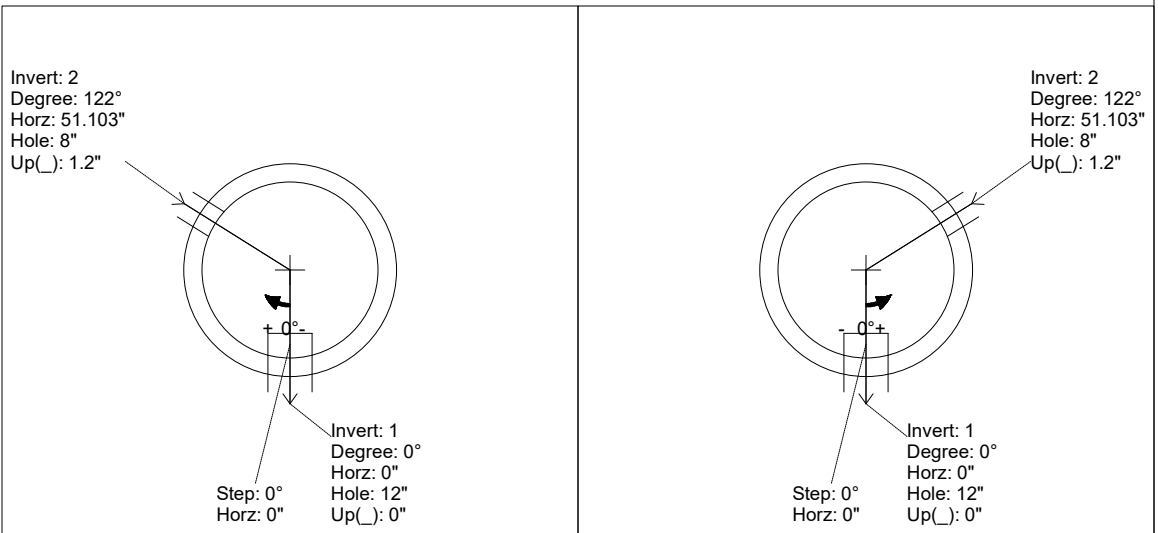

INSIDE WALL DIMENSIONS

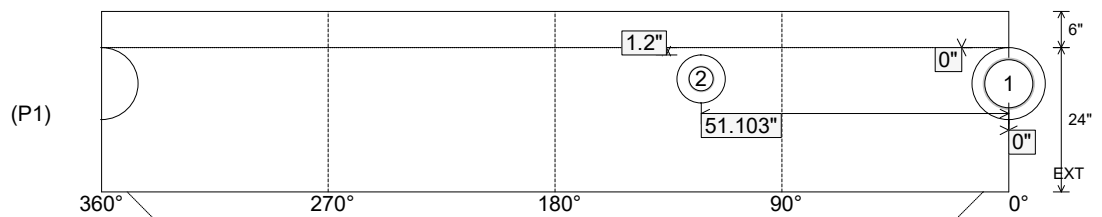

Coating (Int): Coating (Ext):	Seam Up: Tongue Seam Dn: n/a	Wall Thickness: 5" Floor Height: 6"	Height (Int): 24" Height (Ext): 30"	Weight (Net): 2938 lb Volume (Net): 0.75cu.yd
----------------------------------	---------------------------------	--	--	--