

Job Name: 26-1210 Sacramento Gravity Sewer
 Job Location: Sacramento, KY
 Contractor: Scott & Ritter, Inc.

Plant: Beaver Dam
 4/23/2026 8:36:16 AM

Tech: S. Felletter
 PC: T. Lewis



Structure ID: DMH8-35 SS-MH

P3 GR4

GRADE RING F/F

- P4) 24" - CASTING HEIGHT - 7"
- P3) 24" - GRADE RING F/F - 4"
- P2) 48" - ECC CONE w/ 24" HOLE F/G - 36"
- P1) 48" - MH BASE T/n - 30"
- 1) JOINT WRAP - 0.065"x6"x50' CONSEAL CS212
- 1) JOINT WRAP PRIMER - CONSEAL CS-75 (1 gal.)
- 1) 48" - MH INVERT CHANNEL - FULL HEIGHT
- 1) 48" - Conseal CS-102 1.00" (Double)
- 2) PSX - 12-08 DD (DBL Bands)
- 5) MH Step ML-10-TDS-NCR - 10"

0 lb
 270 lb
 3000 lb
 3330 lb
 0 lb
 0 lb
 1440 lb
 0 lb
 16 lb
 0 lb

 Structure Total: 8056 lb

Structure Notes:

1. PER ASTM C478 SPECIFICATIONS.
2. CONCRETE = 4,000 PSI AT 28 DAYS.
3. CASTING BY OTHERS.

REINFORCING PER ASTM A615 (GRADE 60).
 - CONE (As .12)
 - RISER/WALLS (As .12)
 - FLOOR (As .31) #5 BARS AT 12" C.C.E.W.

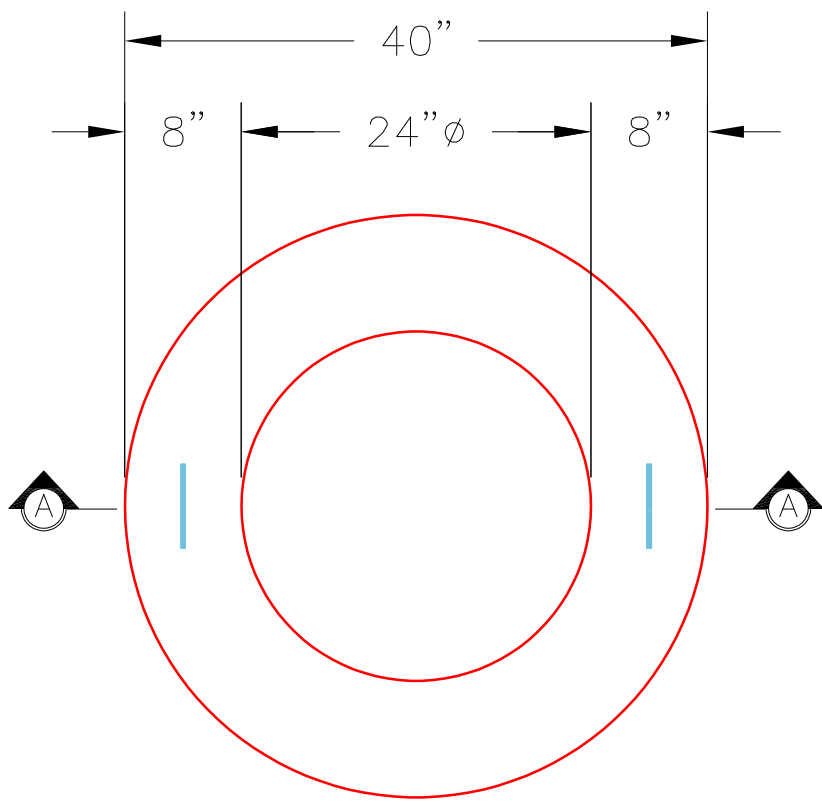

PLAN VIEW

NOTES:

1. GRADE RINGS MEET OR EXCEED THE FOLLOWING SPECIFICATIONS:
 - CONCRETE: 4,000 PSI @ 28 DAYS.
 - REINFORCING: (1) #3 HOOP CENTERED (GRADE 60)
2. WEIGHT: 4" 270 Lbs.

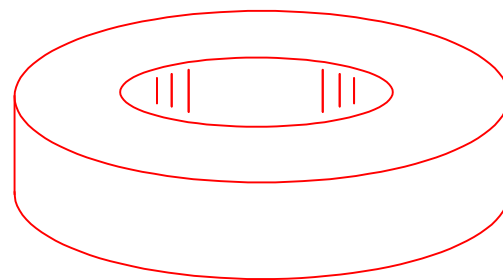

ISOMETRIC VIEW

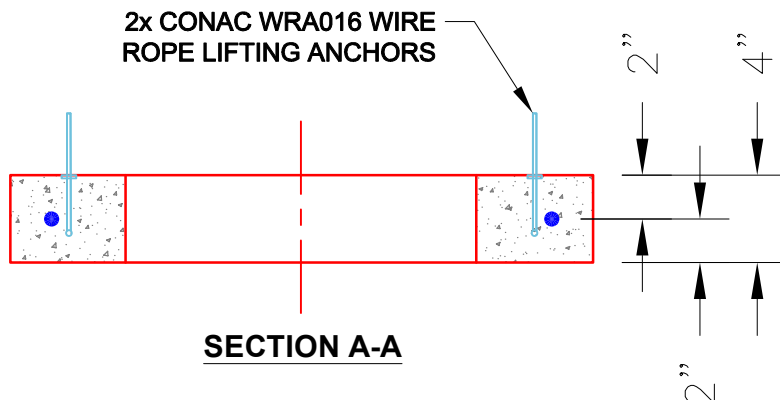

SECTION A-A

Coating (Int):
 Coating (Ext):

Seam Up: Flat
 Seam Dn: Flat

Wall Thickness: 8"

Height (Ext): 4"

Weight (Net): 270 lb
 Volume (Net): 0.07cu.yd