

Job Name: 26-1210 Sacramento Gravity Sewer
 Job Location: Sacramento, KY
 Contractor: Scott & Ritter, Inc.

Plant: Beaver Dam
 4/23/2026 8:35:49 AM

Tech: S. Felletter
 PC: T. Lewis



Structure ID: DMH8-35 SS-MH

P1 MH048BA30

MH BASE T/n

P4) 24" - CASTING HEIGHT - 7"	0 lb
P3) 24" - GRADE RING F/F - 4"	270 lb
P2) 48" - ECC CONE w/ 24" HOLE F/G - 36"	3000 lb
P1) 48" - MH BASE T/n - 30"	3330 lb
1) JOINT WRAP - 0.065"x6"x50' CONSEAL CS212	0 lb
1) JOINT WRAP PRIMER - CONSEAL CS-75 (1 gal.)	0 lb
1) 48" - MH INVERT CHANNEL - FULL HEIGHT	1440 lb
1) 48" - Conseal CS-102 1.00" (Double)	0 lb
2) PSX - 12-08 DD (DBL Bands)	16 lb
5) MH Step ML-10-TDS-NCR - 10"	0 lb
Structure Total:	8056 lb

Structure Notes:
 1. PER ASTM C478 SPECIFICATIONS.
 2. CONCRETE = 4,000 PSI AT 28 DAYS.
 3. CASTING BY OTHERS.

REINFORCING PER ASTM A615 (GRADE 60).
 - CONE (As .12)
 - RISER/WALLS (As .12)
 - FLOOR (As .31) #5 BARS AT 12" C.C.E.W.

Rim: 486.27' Rim to Invert: 6.35' Slack: 1.2' Sump: 2' Step Position: 0°

Position	Elev	Angle	Ext. (cw)	Pipe	Pipe OD	Connector	Hole	Horz Size	Up ()	Offset
Invert 1	479.92'	0°	0"	8" PVC SDR35	8.5"	PSX 12-08 DD (DBL Bands)	12"	12.129"	0"	0"
Invert 2	480.02'	182°	92.118"	8" PVC SDR35	8.5"	PSX 12-08 DD (DBL Bands)	12"	12.129"	1.2"	0"
Invert 3										
Invert 4										
Invert 5										
Invert 6										
Invert 7										
Invert 8										

RIGHT-SIDE UP VIEW (int. dimensions)

UPSIDE-DOWN VIEW (int. dimensions)

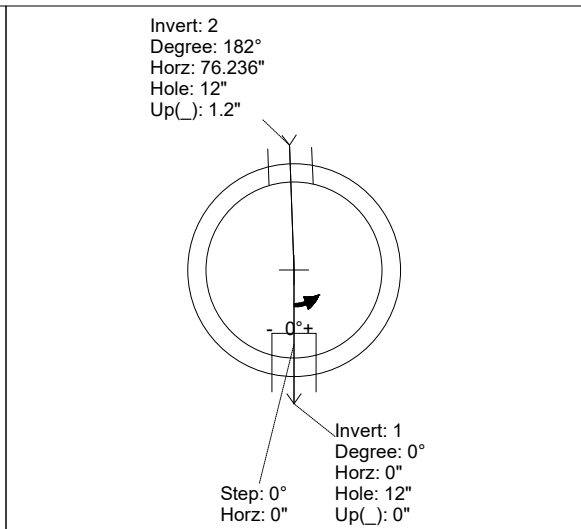
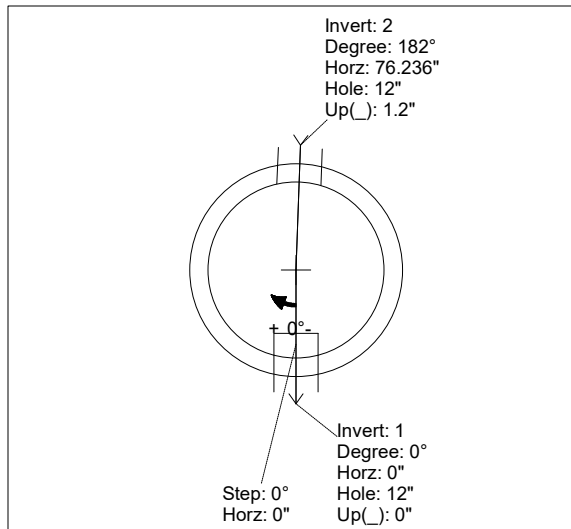
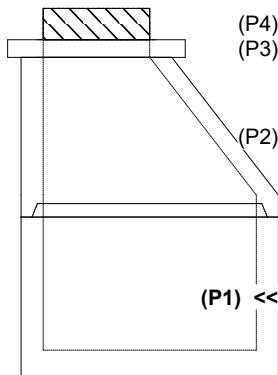

INSIDE WALL DIMENSIONS

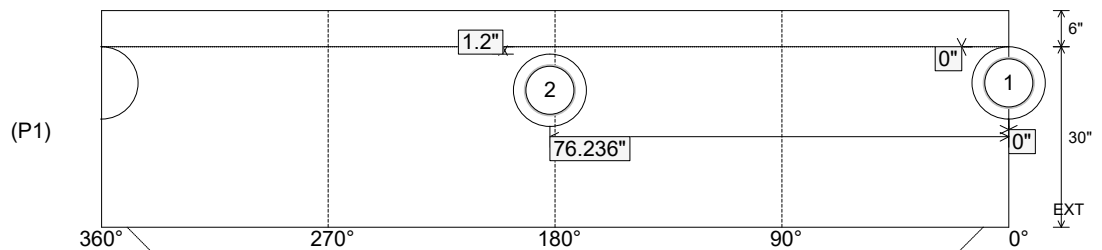

Coating (Int):
 Coating (Ext):

Seam Up: Tongue
 Seam Dn: n/a

Wall Thickness: 5"
 Floor Height: 6"

Height (Int): 30"
 Height (Ext): 36"

Weight (Net): 3330 lb
 Volume (Net): 0.85cu.yd

Job Name: 26-1210 Sacramento Gravity Sewer
 Job Location: Sacramento, KY
 Contractor: Scott & Ritter, Inc.

Plant: Beaver Dam
 4/23/2026 8:35:49 AM

Tech: S. Felletter
 PC: T. Lewis



Structure ID: DMH8-35 SS-MH

P1 MH048BA30

MH BASE T/n

P4) 24" - CASTING HEIGHT - 7"	0 lb
P3) 24" - GRADE RING F/F - 4"	270 lb
P2) 48" - ECC CONE w/ 24" HOLE F/G - 36"	3000 lb
P1) 48" - MH BASE T/n - 30"	3330 lb
1) JOINT WRAP - 0.065"x6"x50' CONSEAL CS212	0 lb
1) JOINT WRAP PRIMER - CONSEAL CS-75 (1 gal.)	0 lb
1) 48" - MH INVERT CHANNEL - FULL HEIGHT	1440 lb
1) 48" - Conseal CS-102 1.00" (Double)	0 lb
2) PSX - 12-08 DD (DBL Bands)	16 lb
5) MH Step ML-10-TDS-NCR - 10"	0 lb
Structure Total:	8056 lb

Structure Notes:
 1. PER ASTM C478 SPECIFICATIONS.
 2. CONCRETE = 4,000 PSI AT 28 DAYS.
 3. CASTING BY OTHERS.

 REINFORCING PER ASTM A615 (GRADE 60).
 - CONE (As .12)
 - RISER/WALLS (As .12)
 - FLOOR (As .31) #5 BARS AT 12" C.C.E.W.

Invert channel drawing - full height invert

Rim: 486.27' Rim to Invert: 6.35' Slack: 1.2' Sump: 2" Step Position: 0°

Position	Elev	Angle	Ext. (cw)	Pipe	Pipe OD	Connector	Hole	Horz Size	Up ()	Offset
Invert 1	479.92'	0°	0"	8" PVC SDR35	8.5"	PSX 12-08 DD (DBL Bands)	12"	12.129"	0"	0"
Invert 2	480.02'	182°	92.118"	8" PVC SDR35	8.5"	PSX 12-08 DD (DBL Bands)	12"	12.129"	1.2"	0"
Invert 3										
Invert 4										
Invert 5										
Invert 6										
Invert 7										
Invert 8										

RIGHT-SIDE UP VIEW (int. dimensions)

UPSIDE-DOWN VIEW (int. dimensions)

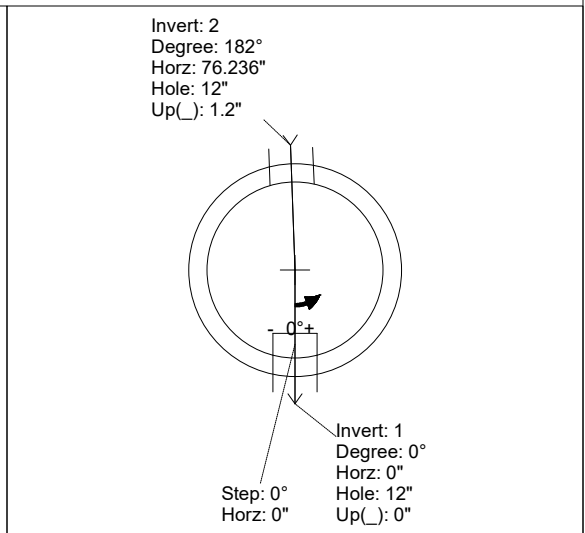
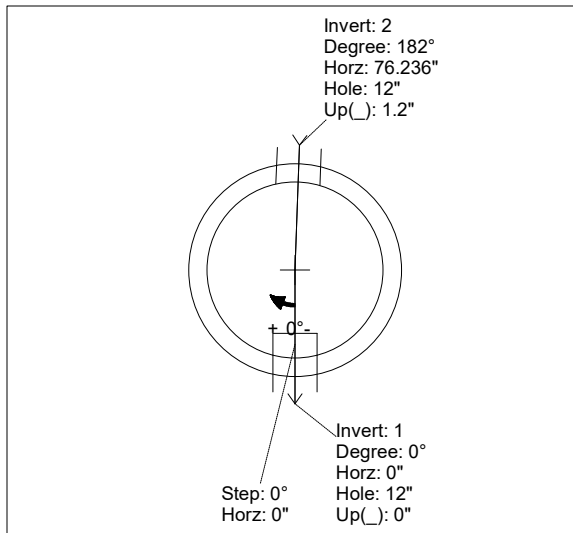
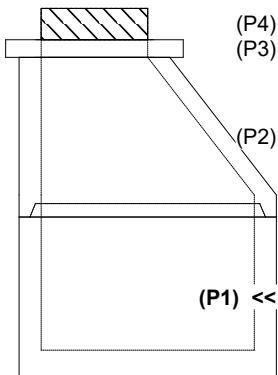

INSIDE WALL DIMENSIONS

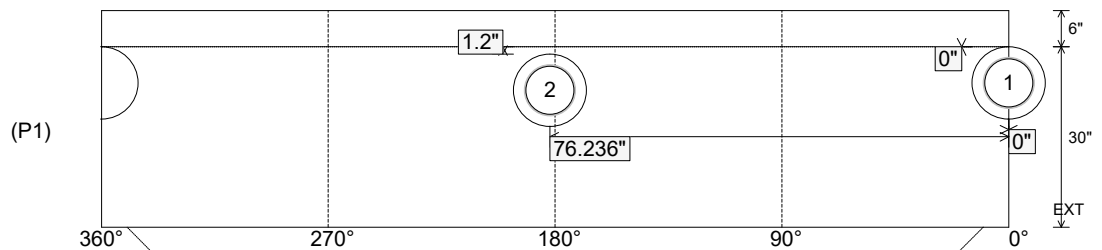

Coating (Int):
 Coating (Ext):

Seam Up: Tongue
 Seam Dn: n/a

Wall Thickness: 5"
 Floor Height: 6"

Height (Int): 30"
 Height (Ext): 36"

Weight (Net): 3330 lb
 Volume (Net): 0.85cu.yd