

Structure ID: DMH2-29 SS-MH

P2 MH048RS60

MH RISER T/G

P5) 24" - CASTING HEIGHT - 7" P4) 24" - GRADE RING F/F - 4" P3) 48" - ECC CONE w/ 24" HOLE F/G - 36" P2) 48" - MH RISER T/G - 60" P1) 48" - MH BASE T/n - 30" 1) JOINT WRAP - 0.065"x6"x50' CONSEAL CS212 1) JOINT WRAP PRIMER - CONSEAL CS-75 (1 gal.) 1) 48" - MH INVERT CHANNEL - FULL HEIGHT 2) 48" - Conseal CS-102 1.00" (Double) 2) PSX - 12-08 DD (DBL Bands) 10) MH Step ML-10-TDS-NCR - 10"	0 lb 270 lb 3000 lb 4192 lb 3330 lb 0 lb 0 lb 1440 lb 0 lb 16 lb 0 lb ----- Structure Total: 12248 lb
---	---

Structure Notes:
 1. PER ASTM C478 SPECIFICATIONS.
 2. CONCRETE = 4,000 PSI AT 28 DAYS.
 3. CASTING BY OTHERS.

REINFORCING PER ASTM A615 (GRADE 60).
 - CONE (As .12)
 - RISER/WALLS (As .12)
 - FLOOR (As .31) #5 BARS AT 12" C.C.E.W.

Rim: 482.67' Rim to Invert: 11.35' Slack: 1.2" Sump: 2" Step Position: 0°

Position	Elev	Angle	Ext. (cw)	Pipe	Pipe OD	Connector	Hole	Horz Size	Up (L)	Offset
Invert 1										
Invert 2										
Invert 3										
Invert 4										
Invert 5										
Invert 6										
Invert 7										
Invert 8										

RIGHT-SIDE UP VIEW (int. dimensions)

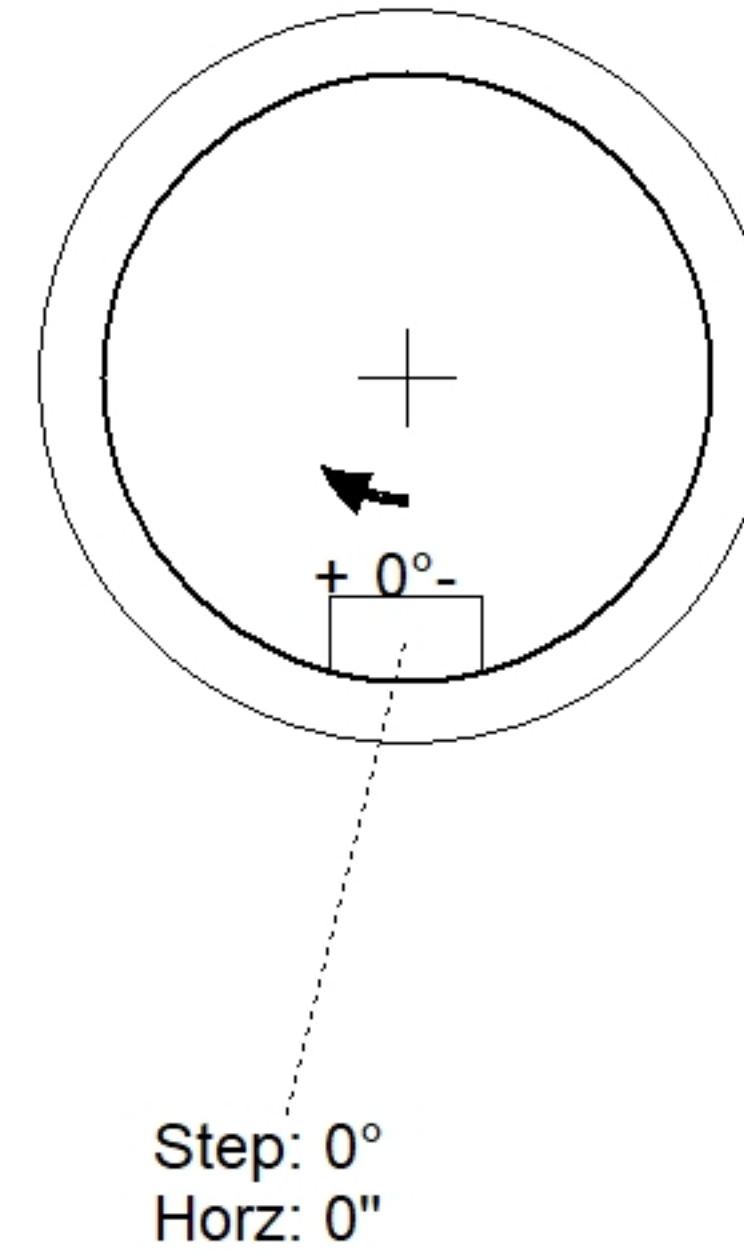
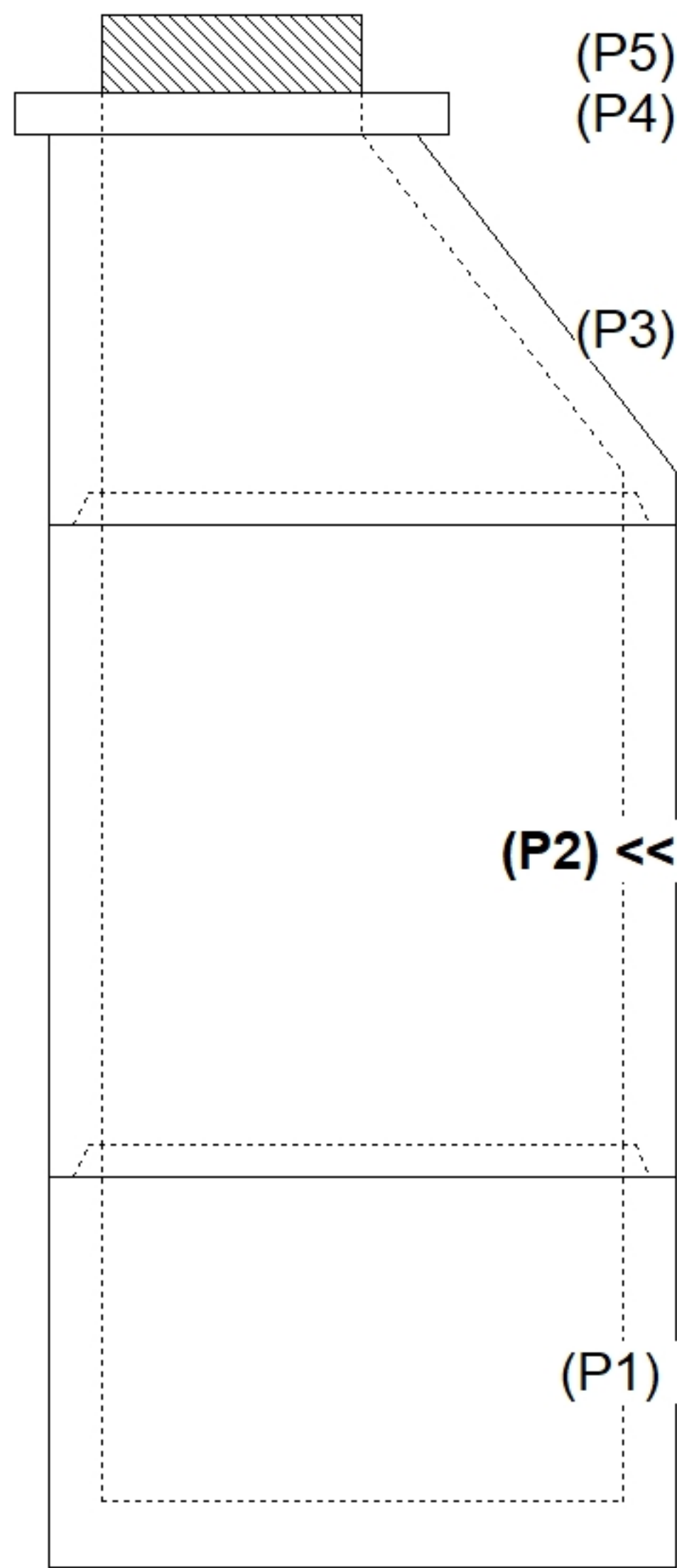

INSIDE WALL DIMENSIONS

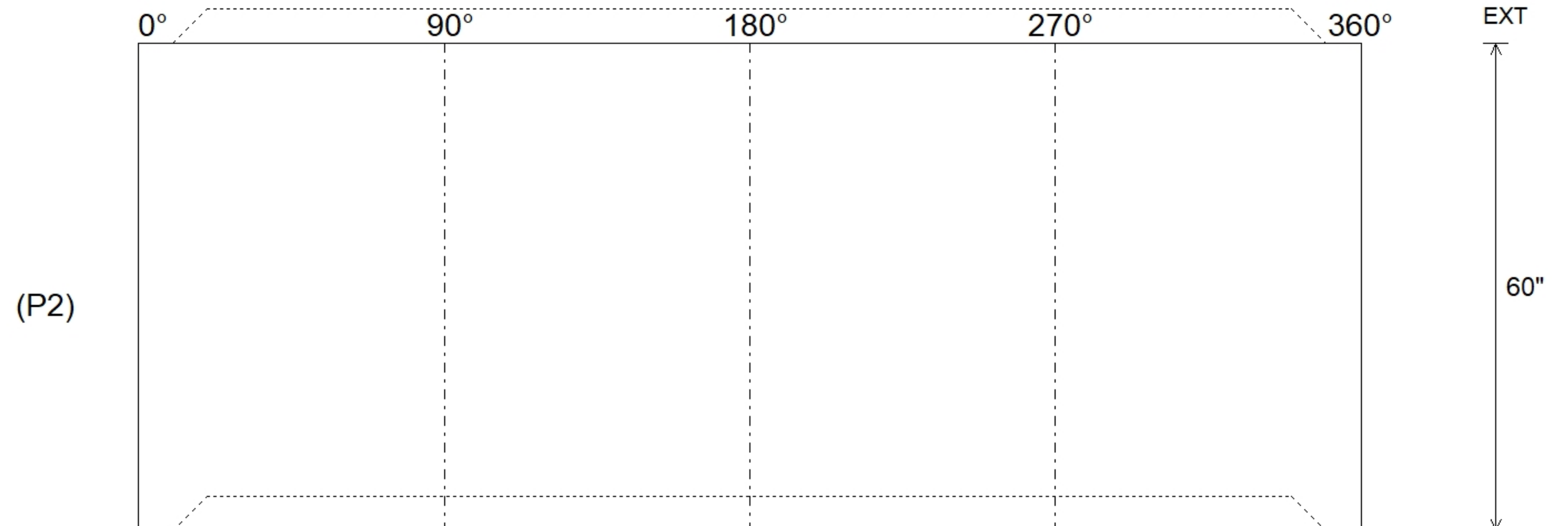

Coating (Int): Coating (Ext):	Seam Up: Tongue Seam Dn: Groove	Wall Thickness: 5" Floor Height: 0"	Height (Int): 60" Height (Ext): 60"	Weight (Net): 4192 lb Volume (Net): 1.07cu.yd
----------------------------------	------------------------------------	--	--	--