

Job Name: 26-1210 Sacramento Gravity Sewer
 Job Location: Sacramento, KY
 Contractor: Scott & Ritter, Inc.

Plant: Beaver Dam
 4/23/2026 8:35:41 AM

Tech: S. Felletter
 PC: T. Lewis



Structure ID: CMH3-21 SS-MH

P1 MH048BA30

MH BASE T/n

| | |
|---|----------------|
| P4) 24" - CASTING HEIGHT - 7" | 0 lb |
| P3) 48" - ECC CONE w/ 24" HOLE F/G - 24" | 1550 lb |
| P2) 48" - MH RISER T/G - 36" | 2515 lb |
| P1) 48" - MH BASE T/n - 30" | 3282 lb |
| 1) JOINT WRAP - 0.065"x6"x50' CONSEAL CS212 | 0 lb |
| 1) JOINT WRAP PRIMER - CONSEAL CS-75 (1 gal.) | 0 lb |
| 1) 48" - MH INVERT CHANNEL - FULL HEIGHT | 1440 lb |
| 2) 48" - Conseal CS-102 1.00" (Double) | 0 lb |
| 3) PSX - 12-08 DD (DBL Bands) | 24 lb |
| 7) MH Step ML-10-TDS-NCR - 10" | 0 lb |
| Structure Total: | 8811 lb |

Structure Notes:
 1. PER ASTM C478 SPECIFICATIONS.
 2. CONCRETE = 4,000 PSI AT 28 DAYS.
 3. CASTING BY OTHERS.

REINFORCING PER ASTM A615 (GRADE 60).
 - CONE (As .12)
 - RISER/WALLS (As .12)
 - FLOOR (As .31) #5 BARS AT 12" C.C.E.W.

Rim: 493.78' Rim to Invert: 8.04' Slack: 1.48" Sump: 2" Step Position: 0°

| Position | Elev | Angle | Ext. (cw) | Pipe | Pipe OD | Connector | Hole | Horz Size | Up () | Offset |
|----------|---------|-------|-----------|--------------|---------|--------------------------|------|-----------|--------|--------|
| Invert 1 | 485.74' | 0° | 0" | 8" PVC SDR35 | 8.5" | PSX 12-08 DD (DBL Bands) | 12" | 12.129" | 0" | 0" |
| Invert 2 | 485.84' | 180° | 91.106" | 8" PVC SDR35 | 8.5" | PSX 12-08 DD (DBL Bands) | 12" | 12.129" | 1.2" | 0" |
| Invert 3 | 485.84' | 270° | 136.659" | 8" PVC SDR35 | 8.5" | PSX 12-08 DD (DBL Bands) | 12" | 12.129" | 1.2" | 0" |
| Invert 4 | | | | | | | | | | |
| Invert 5 | | | | | | | | | | |
| Invert 6 | | | | | | | | | | |
| Invert 7 | | | | | | | | | | |
| Invert 8 | | | | | | | | | | |

RIGHT-SIDE UP VIEW (int. dimensions)

UPSIDE-DOWN VIEW (int. dimensions)

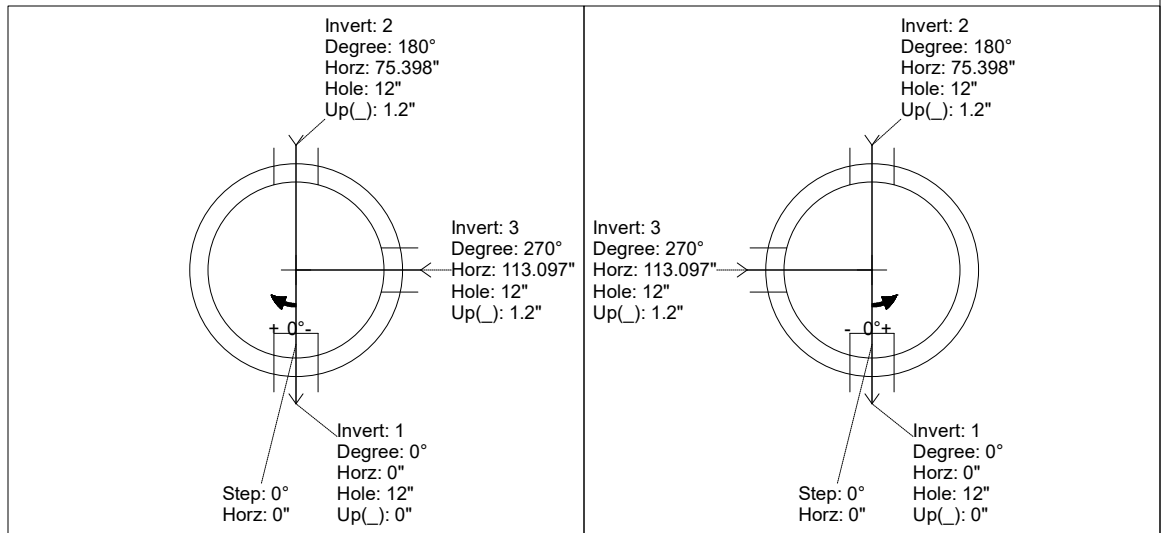

INSIDE WALL DIMENSIONS

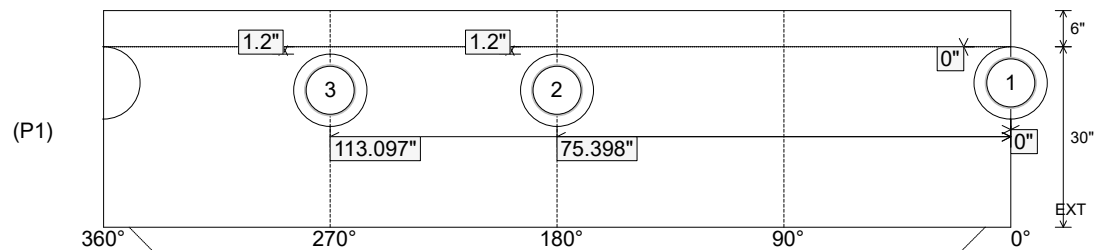

| | | | | |
|----------------------------------|---------------------------------|--|--|--|
| Coating (Int): Coating (Ext): | Seam Up: Tongue Seam Dn: n/a | Wall Thickness: 5" Floor Height: 6" | Height (Int): 30" Height (Ext): 36" | Weight (Net): 3282 lb Volume (Net): 0.84cu.yd |
|----------------------------------|---------------------------------|--|--|--|

Job Name: 26-1210 Sacramento Gravity Sewer
 Job Location: Sacramento, KY
 Contractor: Scott & Ritter, Inc.

Plant: Beaver Dam
 4/23/2026 8:35:41 AM

Tech: S. Felletter
 PC: T. Lewis



Structure ID: CMH3-21 SS-MH

P1 MH048BA30

MH BASE T/n

- P4) 24" - CASTING HEIGHT - 7"
- P3) 48" - ECC CONE w/ 24" HOLE F/G - 24"
- P2) 48" - MH RISER T/G - 36"
- P1) 48" - MH BASE T/n - 30"
- 1) JOINT WRAP - 0.065"x6"x50' CONSEAL CS212
- 1) JOINT WRAP PRIMER - CONSEAL CS-75 (1 gal.)
- 1) 48" - MH INVERT CHANNEL - FULL HEIGHT
- 2) 48" - Conseal CS-102 1.00" (Double)
- 3) PSX - 12-08 DD (DBL Bands)
- 7) MH Step ML-10-TDS-NCR - 10"

0 lb
 1550 lb
 2515 lb
 3282 lb
 0 lb
 0 lb
 1440 lb
 0 lb
 24 lb
 0 lb

 Structure Total: 8811 lb

Structure Notes:
 1. PER ASTM C478 SPECIFICATIONS.
 2. CONCRETE = 4,000 PSI AT 28 DAYS.
 3. CASTING BY OTHERS.

 REINFORCING PER ASTM A615 (GRADE 60).
 - CONE (As .12)
 - RISER/WALLS (As .12)
 - FLOOR (As .31) #5 BARS AT 12" C.C.E.W.

Invert channel drawing - full height invert

Rim: 493.78' Rim to Invert: 8.04' Slack: 1.48" Sump: 2" Step Position: 0°

| Position | Elev | Angle | Ext. (cw) | Pipe | Pipe OD | Connector | Hole | Horz Size | Up () | Offset |
|----------|---------|-------|-----------|--------------|---------|--------------------------|------|-----------|--------|--------|
| Invert 1 | 485.74' | 0° | 0" | 8" PVC SDR35 | 8.5" | PSX 12-08 DD (DBL Bands) | 12" | 12.129" | 0" | 0" |
| Invert 2 | 485.84' | 180° | 91.106" | 8" PVC SDR35 | 8.5" | PSX 12-08 DD (DBL Bands) | 12" | 12.129" | 1.2" | 0" |
| Invert 3 | 485.84' | 270° | 136.659" | 8" PVC SDR35 | 8.5" | PSX 12-08 DD (DBL Bands) | 12" | 12.129" | 1.2" | 0" |
| Invert 4 | | | | | | | | | | |
| Invert 5 | | | | | | | | | | |
| Invert 6 | | | | | | | | | | |
| Invert 7 | | | | | | | | | | |
| Invert 8 | | | | | | | | | | |

RIGHT-SIDE UP VIEW (int. dimensions)

UPSIDE-DOWN VIEW (int. dimensions)

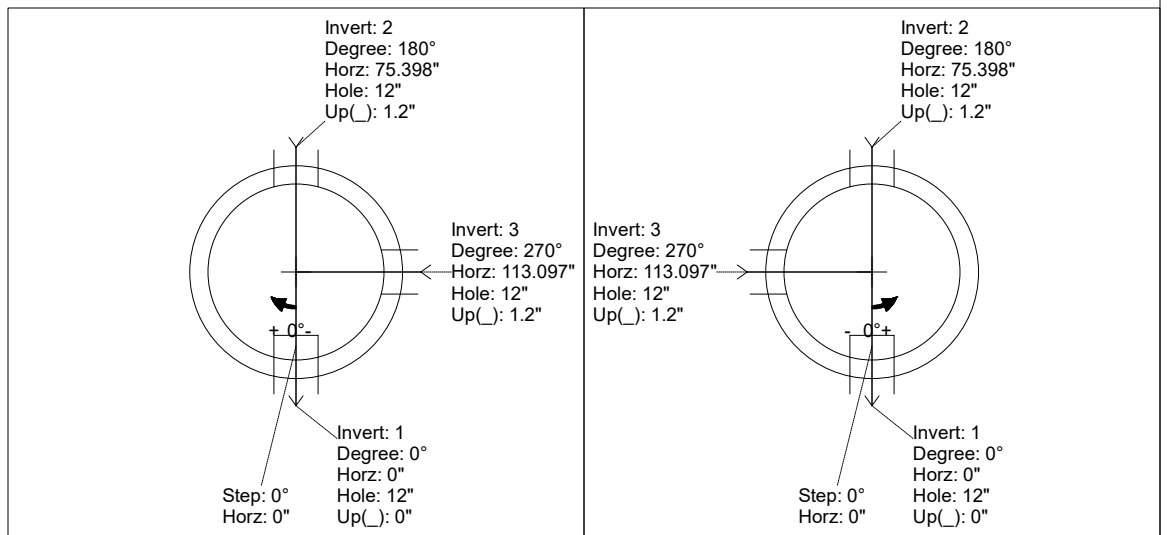

INSIDE WALL DIMENSIONS

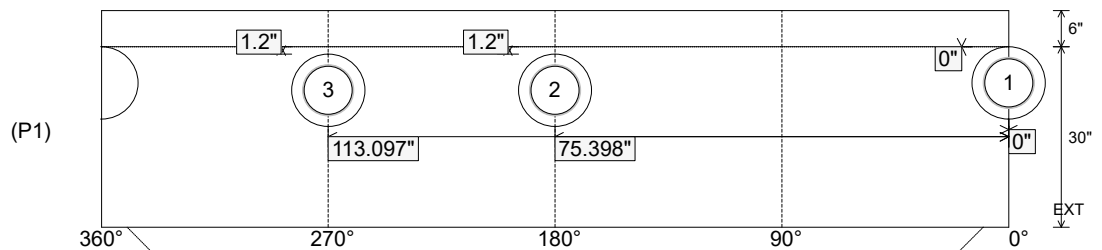

Coating (Int):
 Coating (Ext):

Seam Up: Tongue
 Seam Dn: n/a

Wall Thickness: 5"
 Floor Height: 6"

Height (Int): 30"
 Height (Ext): 36"

Weight (Net): 3282 lb
 Volume (Net): 0.84cu.yd