

Job Name: 26-1210 Sacramento Gravity Sewer  
 Job Location: Sacramento, KY  
 Contractor: Scott & Ritter, Inc.

Plant: Beaver Dam  
 4/23/2026 8:35:41 AM

Tech: S. Felletter  
 PC: T. Lewis



**Structure ID: CMH2-20 SS-MH**

**P1 MH048BA30**

**MH BASE T/n**

- P3) 24" - CASTING HEIGHT - 7"
- P2) 48" - ECC CONE w/ 24" HOLE F/G - 24"
- P1) 48" - MH BASE T/n - 30"

- 1) JOINT WRAP - 0.065"x6"x50' CONSEAL CS212
- 1) JOINT WRAP PRIMER - CONSEAL CS-75 (1 gal.)
- 1) 48" - MH INVERT CHANNEL - FULL HEIGHT
- 1) 48" - Conseal CS-102 1.00" (Double)
- 2) PSX - 12-08 DD (DBL Bands)
- 4) MH Step ML-10-TDS-NCR - 10"

0 lb  
 1550 lb  
 3330 lb  
 0 lb  
 0 lb  
 1440 lb  
 0 lb  
 16 lb  
 0 lb  
 -----  
 Structure Total: 6336 lb

Structure Notes:

1. PER ASTM C478 SPECIFICATIONS.
2. CONCRETE = 4,000 PSI AT 28 DAYS.
3. CASTING BY OTHERS.

REINFORCING PER ASTM A615 (GRADE 60).

- CONE (As .12)
- RISER/WALLS (As .12)
- FLOOR (As .31) #5 BARS AT 12" C.C.E.W.

Rim: 483.76' Rim to Invert: 5.1' Slack: 2.2" Sump: 2" Step Position: 0"

Position	Elev	Angle	Ext. (cw)	Pipe	Pipe OD	Connector	Hole	Horz Size	Up ( )	Offset
Invert 1	478.66'	0°	0"	8" PVC SDR35	8.5"	PSX 12-08 DD (DBL Bands)	12"	12.129"	0"	0"
Invert 2	478.76'	174°	88.069"	8" PVC SDR35	8.5"	PSX 12-08 DD (DBL Bands)	12"	12.129"	1.2"	0"
Invert 3										
Invert 4										
Invert 5										
Invert 6										
Invert 7										
Invert 8										

RIGHT-SIDE UP VIEW (int. dimensions)

UPSIDE-DOWN VIEW (int. dimensions)

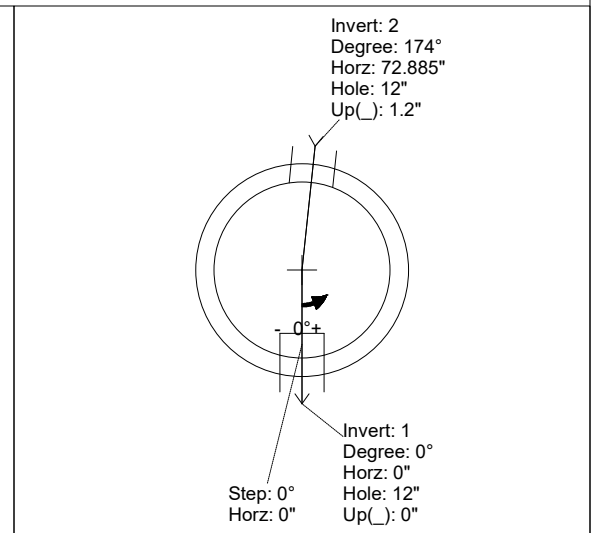
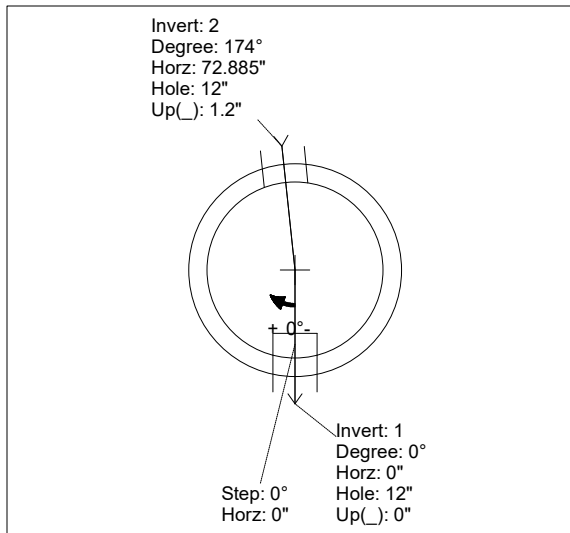
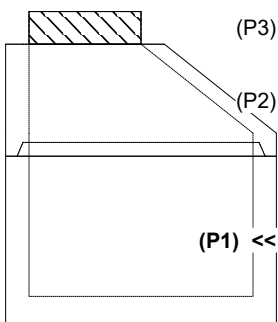

INSIDE WALL DIMENSIONS

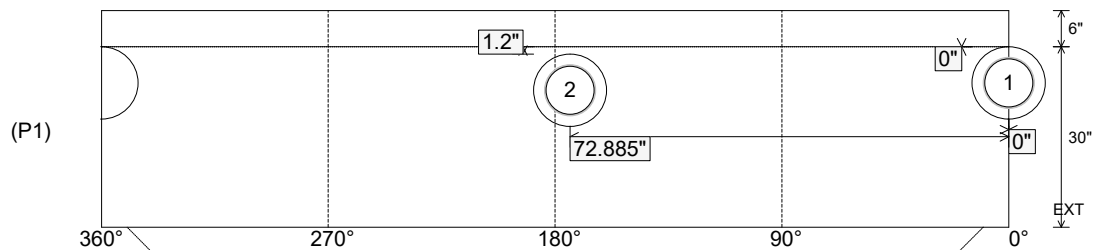

Coating (Int):  
 Coating (Ext):

Seam Up: Tongue  
 Seam Dn: n/a

Wall Thickness: 5"  
 Floor Height: 6"

Height (Int): 30"  
 Height (Ext): 36"

Weight (Net): 3330 lb  
 Volume (Net): 0.85cu.yd

Job Name: 26-1210 Sacramento Gravity Sewer  
 Job Location: Sacramento, KY  
 Contractor: Scott & Ritter, Inc.

Plant: Beaver Dam  
 4/23/2026 8:35:41 AM

Tech: S. Felletter  
 PC: T. Lewis



**Structure ID: CMH2-20 SS-MH**

**P1 MH048BA30**

**MH BASE T/n**

- P3) 24" - CASTING HEIGHT - 7"
- P2) 48" - ECC CONE w/ 24" HOLE F/G - 24"
- P1) 48" - MH BASE T/n - 30"

- 1) JOINT WRAP - 0.065"x6"x50' CONSEAL CS212
- 1) JOINT WRAP PRIMER - CONSEAL CS-75 (1 gal.)
- 1) 48" - MH INVERT CHANNEL - FULL HEIGHT
- 1) 48" - Conseal CS-102 1.00" (Double)
- 2) PSX - 12-08 DD (DBL Bands)
- 4) MH Step ML-10-TDS-NCR - 10"

0 lb  
 1550 lb  
 3330 lb  
 0 lb  
 0 lb  
 1440 lb  
 0 lb  
 16 lb  
 0 lb  
 -----  
 Structure Total: 6336 lb

Structure Notes:

1. PER ASTM C478 SPECIFICATIONS.
2. CONCRETE = 4,000 PSI AT 28 DAYS.
3. CASTING BY OTHERS.

REINFORCING PER ASTM A615 (GRADE 60).

- CONE (As .12)
- RISER/WALLS (As .12)
- FLOOR (As .31) #5 BARS AT 12" C.C.E.W.

**Invert channel drawing - full height invert**

Rim: 483.76' Rim to Invert: 5.1' Slack: 2.2' Sump: 2' Step Position: 0°

Position	Elev	Angle	Ext. (cw)	Pipe	Pipe OD	Connector	Hole	Horz Size	Up ( )	Offset
Invert 1	478.66'	0°	0"	8" PVC SDR35	8.5"	PSX 12-08 DD (DBL Bands)	12"	12.129"	0"	0"
Invert 2	478.76'	174°	88.069"	8" PVC SDR35	8.5"	PSX 12-08 DD (DBL Bands)	12"	12.129"	1.2"	0"
Invert 3										
Invert 4										
Invert 5										
Invert 6										
Invert 7										
Invert 8										

RIGHT-SIDE UP VIEW (int. dimensions)

UPSIDE-DOWN VIEW (int. dimensions)

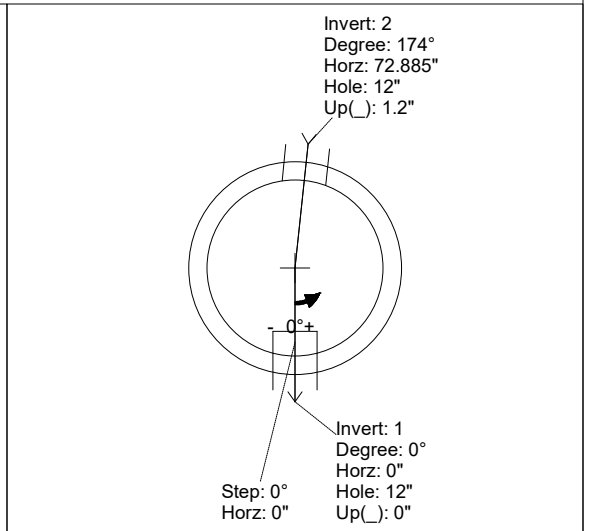
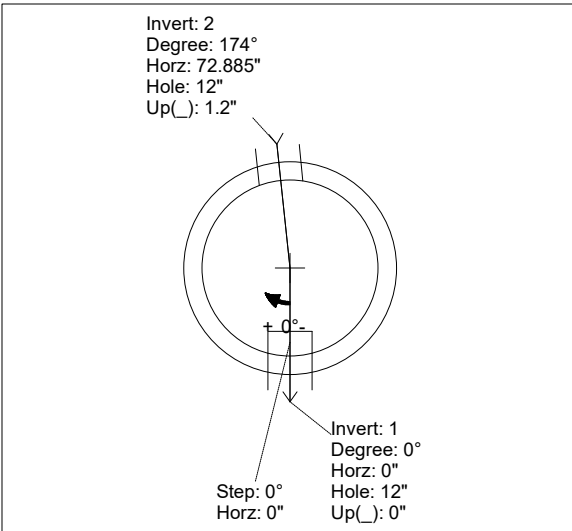
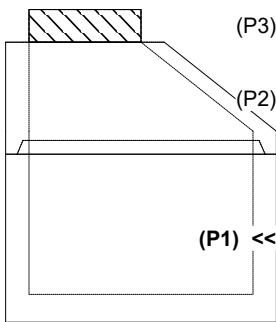

INSIDE WALL DIMENSIONS

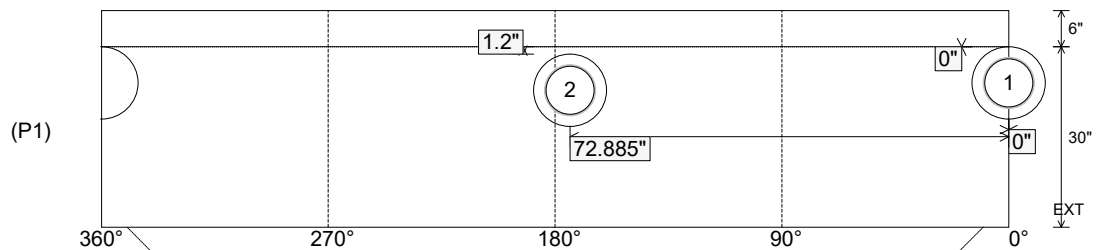

Coating (Int):  
 Coating (Ext):

Seam Up: Tongue  
 Seam Dn: n/a

Wall Thickness: 5"  
 Floor Height: 6"

Height (Int): 30"  
 Height (Ext): 36"

Weight (Net): 3330 lb  
 Volume (Net): 0.85cu.yd