

Job Name: 26-1210 Sacramento Gravity Sewer	Plant: Beaver Dam	Tech: S. Felletter	
Job Location: Sacramento, KY Contractor: Scott & Ritter, Inc.	4/24/2026 8:09:30 AM	PC: T. Lewis	

**Structure ID: BMH4-15 SS-MH**

**P2 MH048CN30**

**ECC CONE w/ 24" HOLE F/G**

P4) 24" - CASTING HEIGHT - 7"	0 lb
P3) 24" - GRADE RING F/F - 3"	202 lb
P2) 48" - ECC CONE w/ 24" HOLE F/G - 30"	2050 lb
P1) 48" - MH BASE T/n - 30"	3330 lb
1) JOINT WRAP - 0.065"x6"x50' CONSEAL CS212	0 lb
1) JOINT WRAP PRIMER - CONSEAL CS-75 (1 gal.)	0 lb
1) 48" - MH INVERT CHANNEL - FULL HEIGHT	1440 lb
1) 48" - Conseal CS-102 1.00" (Double)	0 lb
2) PSX - 12-08 DD (DBL Bands)	16 lb
5) MH Step ML-10-TDS-NCR - 10"	0 lb
<b>Structure Total:</b>	<b>7039 lb</b>

**Structure Notes:**  
 1. PER ASTM C478 SPECIFICATIONS.  
 2. CONCRETE = 4,000 PSI AT 28 DAYS.  
 3. CASTING BY OTHERS.

REINFORCING PER ASTM A615 (GRADE 60).  
 - CONE (As .12)  
 - RISER/WALLS (As .12)  
 - FLOOR (As .31) #5 BARS AT 12" C.C.E.W.

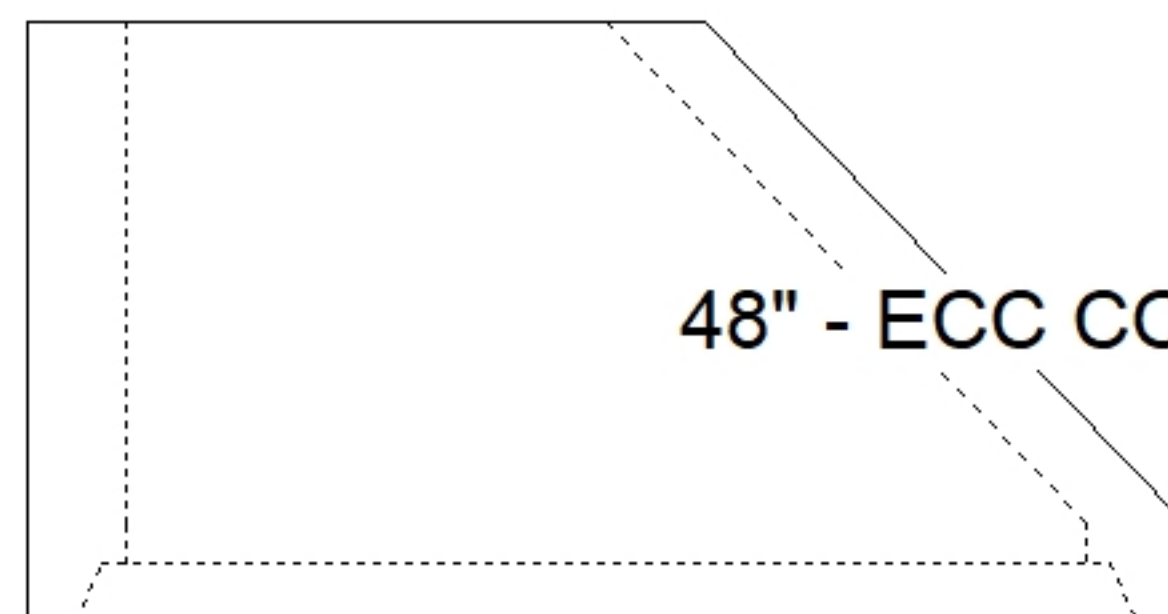
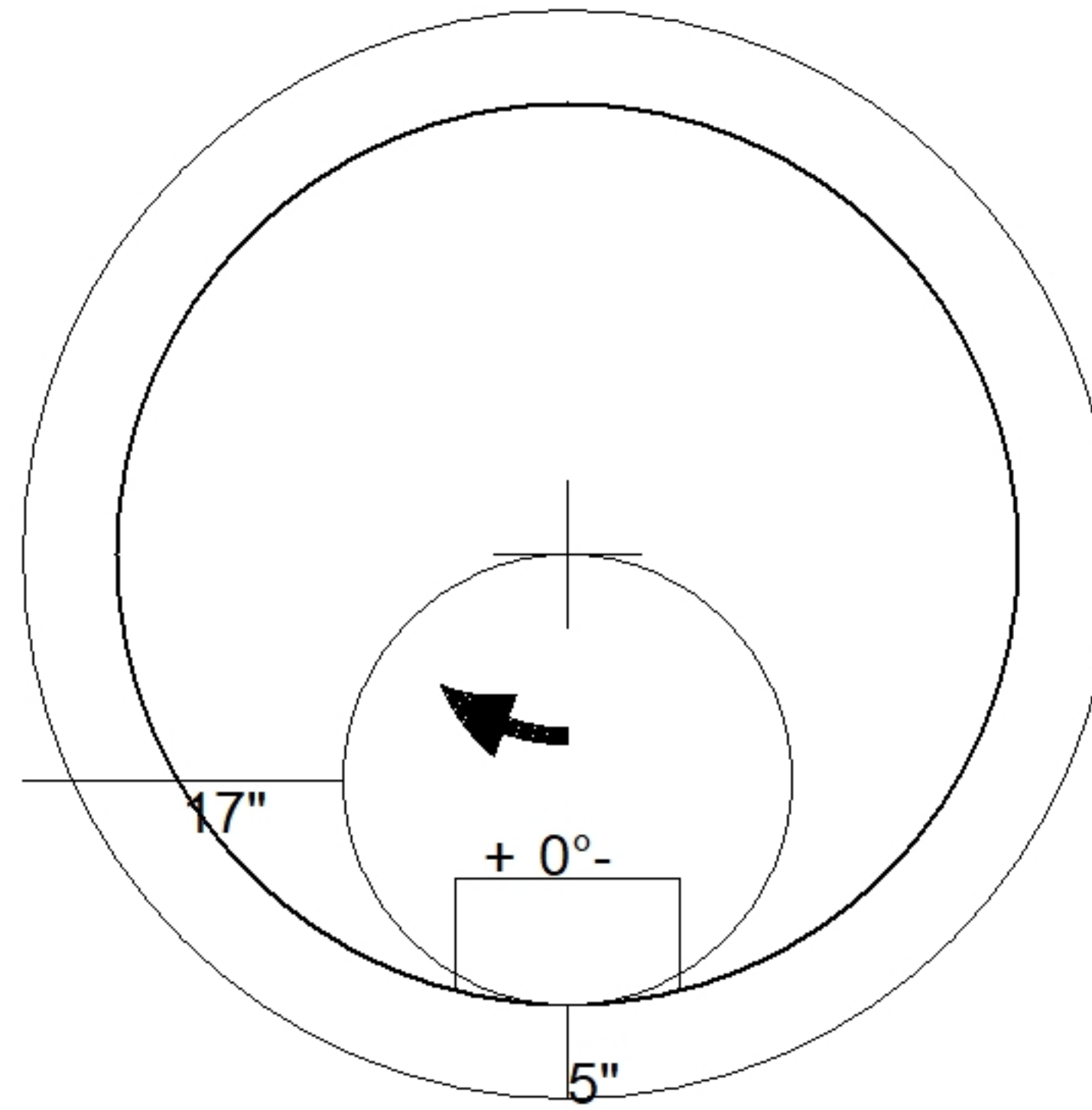

48" - ECC CONE w/ 24" HOLE F/G - 30" - (P2)

Coating (Int):	Seam Up: Flat	Wall Thickness: 5"	Height (Ext): 30"	Weight (Net): 2050 lb
Coating (Ext):	Seam Dn: Groove			Volume (Net): 0.41cu.yd