

Job Name: 26-1191 - Red River Ridge Ph 4 Sanitary  
 Job Location: Clarksville, TN  
 Contractor: Byard Construction, LLC

Plant: 100

Tech: J. Horsley

2/18/2026 2:52:50 PM

PC: A. Chambers



**Structure ID: MH 1-8-7 SS-MH**

**P1 MH048BA36CDARED**

**MH BASE w/ConBlock-CDA Red T/n**

P5) 24" - CASTING HEIGHT - 6"	0 lb
P4) 48" - ECC CONE w/ 24" HOLE, w/ConBlock-CDA Red F/G - 42"	3116 lb
P3) 48" - MH RISER w/ConBlock-CDA Red T/G - 60"	4192 lb
P2) 48" - MH RISER w/ConBlock-CDA Red T/G - 60"	4192 lb
P1) 48" - MH BASE w/ConBlock-CDA Red T/n - 36"	3749 lb
1) 48" - MH INVERT CHANNEL w/ConBlock-CDA Red - FULL HEIGHT	1440 lb
1) ADMIXTURE CONBLOCK CDA RED	0 lb
1) JOINT WRAP - 0.065"x6"x50" CONSEAL CS212	0 lb
1) JOINT WRAP PRIMER - CONSEAL CS-75 (1 gal.)	0 lb
1) CASTING - JBS 1155 F/C SANITARY	250 lb
3) 48" - Conseal CS-102 1.00" (Double)	0 lb
2) PSX - 12-08 NYLO	16 lb
17) MH Step ML-10-TDS-NCR - 10"	0 lb
<b>Structure Total:</b>	<b>16955 lb</b>

- Structure Notes:**
1. PER ASTM C-478 SPECIFICATIONS
  2. CONCRETE: 4,000 PSI AT 28 DAYS
  3. REINFORCEMENT: PER ASTM A615
  4. INVERT CHANNEL REQUIRED
  5. CONBLOCK CDA RED ADMIXTURE REQUIRED
  6. STEPS AT 106 DEGREES
  7. JBS 1155 FRAME & COVER "SANITARY" SUPPLIED BY ICAST

Rim: 486.56' Rim to Invert: 17.06' Slack: 2.72" Sump: 2" Step Position: 106°

Position	Elev	Angle	Ext. (cw)	Pipe	Pipe OD	Connector	Hole	Horz Size	Up ( )	Offset
Invert 1	469.5'	0°	0"	8" PVC SDR26	8.5"	PSX 12-08 NYLO	12"	12.129"	0"	0"
Invert 2	469.7'	212°	107.303"	8" PVC SDR26	8.5"	PSX 12-08 NYLO	12"	12.129"	2.4"	0"
Invert 3										
Invert 4										
Invert 5										
Invert 6										
Invert 7										
Invert 8										

RIGHT-SIDE UP VIEW (int. dimensions)

UPSIDE-DOWN VIEW (int. dimensions)

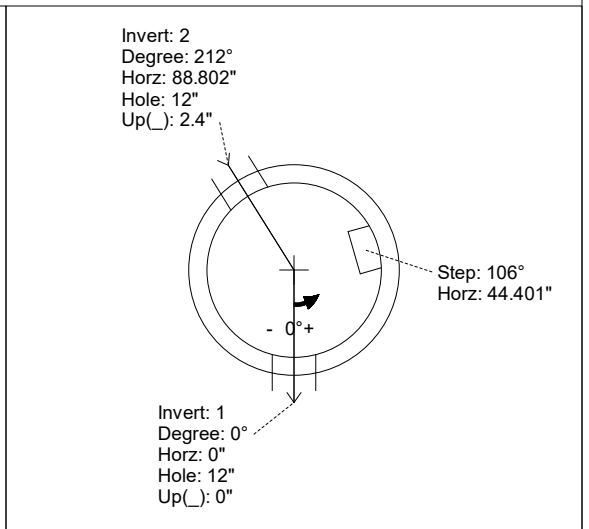
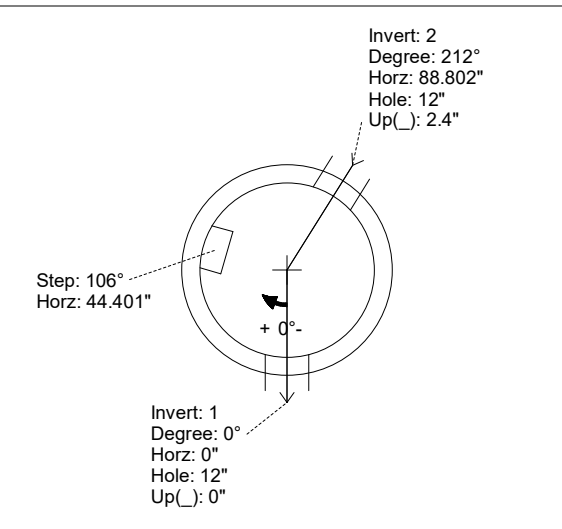
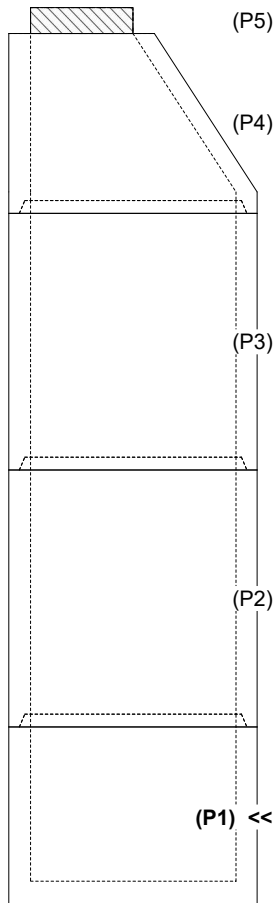

INSIDE WALL DIMENSIONS

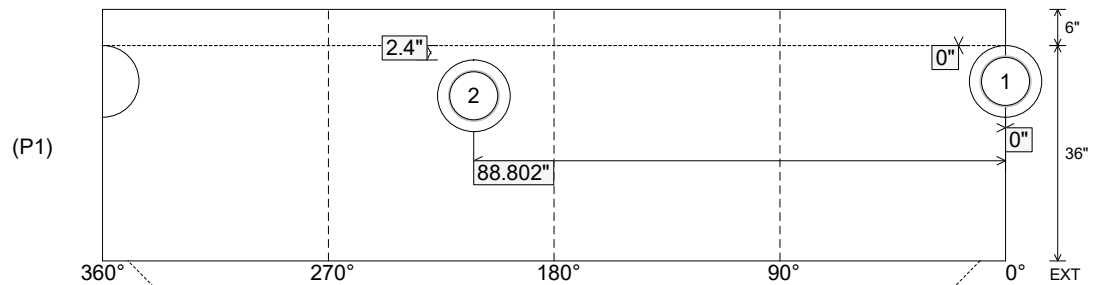

Coating (Int):  
Coating (Ext):

Seam Up: Tongue  
Seam Dn: n/a

Wall Thickness: 5"  
Floor Height: 6"

Height (Int): 36"  
Height (Ext): 42"

Weight (Net): 3749 lb  
Volume (Net): 0.96cu.yd

**Structure ID: MH 1-8-7 SS-MH**

**P1 MH048BA36CDARED**

**MH BASE w/ConBlock-CDA Red T/n**

P5) 24" - CASTING HEIGHT - 6" P4) 48" - ECC CONE w/ 24" HOLE, w/ConBlock-CDA Red F/G - 42" P3) 48" - MH RISER w/ConBlock-CDA Red T/G - 60" P2) 48" - MH RISER w/ConBlock-CDA Red T/G - 60" P1) 48" - MH BASE w/ConBlock-CDA Red T/n - 36" 1) 48" - MH INVERT CHANNEL w/ConBlock-CDA Red - FULL HEIGHT 1) ADMIXTURE CONBLOCK CDA RED 1) JOINT WRAP - 0.065"x6"x50" CONSEAL CS212 1) JOINT WRAP PRIMER - CONSEAL CS-75 (1 gal.) 1) CASTING - JBS 1155 F/C SANITARY 3) 48" - Conseal CS-102 1.00" (Double) 2) PSX - 12-08 NYLO 17) MH Step ML-10-TDS-NCR - 10"	0 lb 3116 lb 4192 lb 4192 lb 3749 lb 1440 lb 0 lb 0 lb 0 lb 0 lb 250 lb 0 lb 16 lb 0 lb ----- Structure Total: 16955 lb
---	--

- Structure Notes:
1. PER ASTM C-478 SPECIFICATIONS
  2. CONCRETE: 4,000 PSI AT 28 DAYS
  3. REINFORCEMENT: PER ASTM A615
  4. INVERT CHANNEL REQUIRED
  5. CONBLOCK CDA RED ADMIXTURE REQUIRED
  6. STEPS AT 106 DEGREES
  7. JBS 1155 FRAME & COVER "SANITARY" SUPPLIED BY ICAST

Rim: 486.56'    Rim to Invert: 17.06'    Slack: 2.72"    Sump: 2"    Step Position: 106°

Position	Elev	Angle	Ext. (cw)	Pipe	Pipe OD	Connector	Hole	Horz Size	Up ( )	Offset
Invert 1	469.5'	0°	0"	8" PVC SDR26	8.5"	PSX 12-08 NYLO	12"	12.129"	0"	0"
Invert 2	469.7'	212°	107.303"	8" PVC SDR26	8.5"	PSX 12-08 NYLO	12"	12.129"	2.4"	0"
Invert 3										
Invert 4										
Invert 5										
Invert 6										
Invert 7										
Invert 8										

RIGHT-SIDE UP VIEW (int. dimensions)      UPSIDE-DOWN VIEW (int. dimenions)

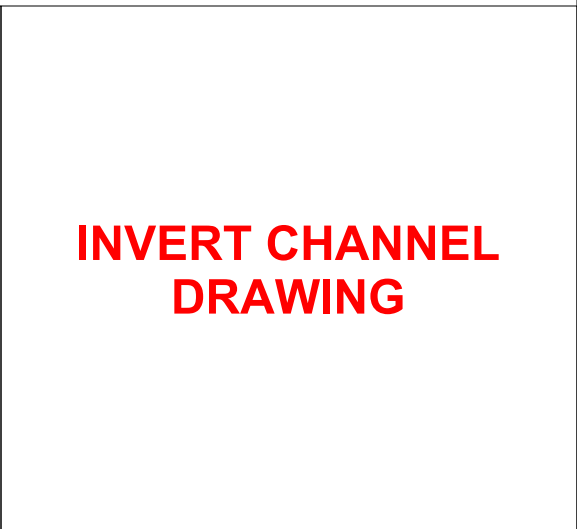
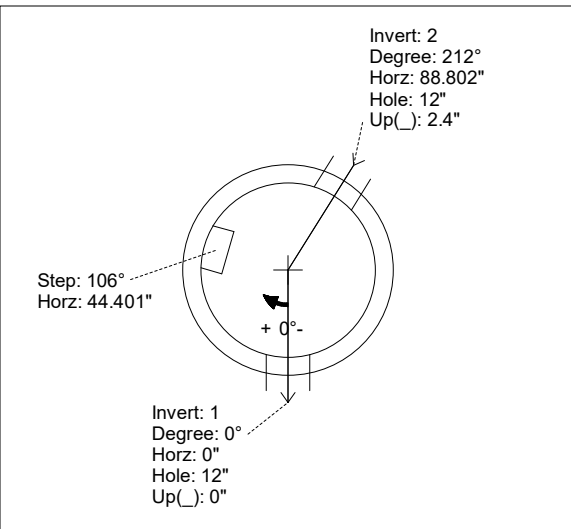
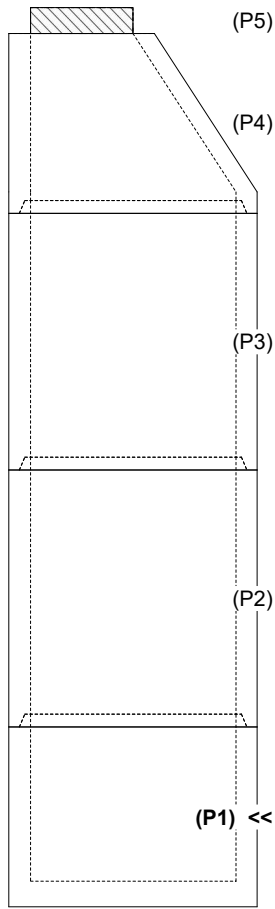

INSIDE WALL DIMENSIONS

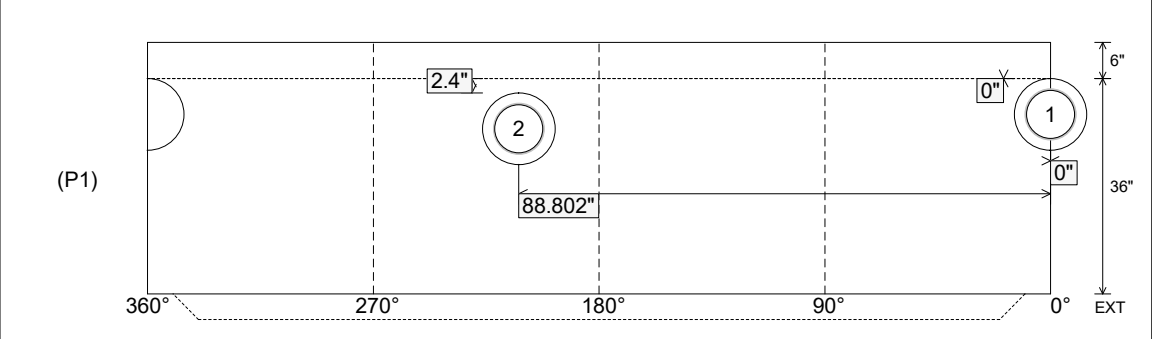

Coating (Int): Coating (Ext):	Seam Up: Tongue Seam Dn: n/a	Wall Thickness: 5" Floor Height: 6"	Height (Int): 36" Height (Ext): 42"	Weight (Net): 3749 lb Volume (Net): 0.96cu.yd
----------------------------------	---------------------------------	--	--	--