

Structure ID: MH 1-6-5 SS-MH

P2 MH048RS72CDARED

MH RISER w/ConBlock-CDA Red T/G

P6) 24" - CASTING HEIGHT - 6" P5) 24" - GRADE RING w/ConBlock-CDA Red F/F - 4" P4) 48" - ECC CONE w/ 24" HOLE, w/ConBlock-CDA Red F/G - 42" P3) 48" - MH RISER SPECIAL w/ConBlock-CDA Red T/G - 60" P2) 48" - MH RISER w/ConBlock-CDA Red T/G - 72" P1) 48" - MH BASE w/ConBlock-CDA Red T/n - 30" 1) 48" - MH INVERT CHANNEL w/ConBlock-CDA Red - FULL HEIGHT 1) ADMIXTURE CONBLOCK CDA RED 1) JOINT WRAP - 0.065"x6"x50' CONSEAL CS212 1) JOINT WRAP PRIMER - CONSEAL CS-75 (1 gal.) 1) CASTING - JBS 1155 F/C SANITARY 3) 48" - Conseal CS-102 1.00" (Double) 2) PSX - 12-08 NYLO 2) PSX - 8QRS-S NYLO 17) MH Step ML-10-TDS-NCR - 10"	0 lb 270 lb 3116 lb 4149 lb 5030 lb 3330 lb 1440 lb 0 lb 0 lb 0 lb 250 lb 0 lb 16 lb 13 lb 0 lb ----- Structure Total: 17614 lb
-------------------------------------------------------------------------------------------------------------------------------------------------------------------------------------------------------------------------------------------------------------------------------------------------------------------------------------------------------------------------------------------------------------------------------------------------------------------------------------------------------------------------------------------------------------------------------------------------------------------------------------------------------------------------------------	---------------------------------------------------------------------------------------------------------------------------------------------------------------------------------

Structure Notes:

1. PER ASTM C-478 SPECIFICATIONS
2. CONCRETE: 4,000 PSI AT 28 DAYS
3. REINFORCEMENT: PER ASTM A615
4. CONBLOCK CDA RED ADMIXTURE REQUIRED
5. STEPS AT 277.5 DEGREES
6. JBS 1155 FRAME & COVER "SANITARY" SUPPLIED BY ICAST

Rim: 485.74' Rim to Invert: 17.69' Slack: 0.28" Sump: 2" Step Position: 277.5°

Position	Elev	Angle	Ext. (cw)	Pipe	Pipe OD	Connector	Hole	Horz Size	Up ()	Offset
Invert 1										
Invert 2										
Invert 3										
Invert 4										
Invert 5										
Invert 6										
Invert 7										
Invert 8										

RIGHT-SIDE UP VIEW (int. dimensions)

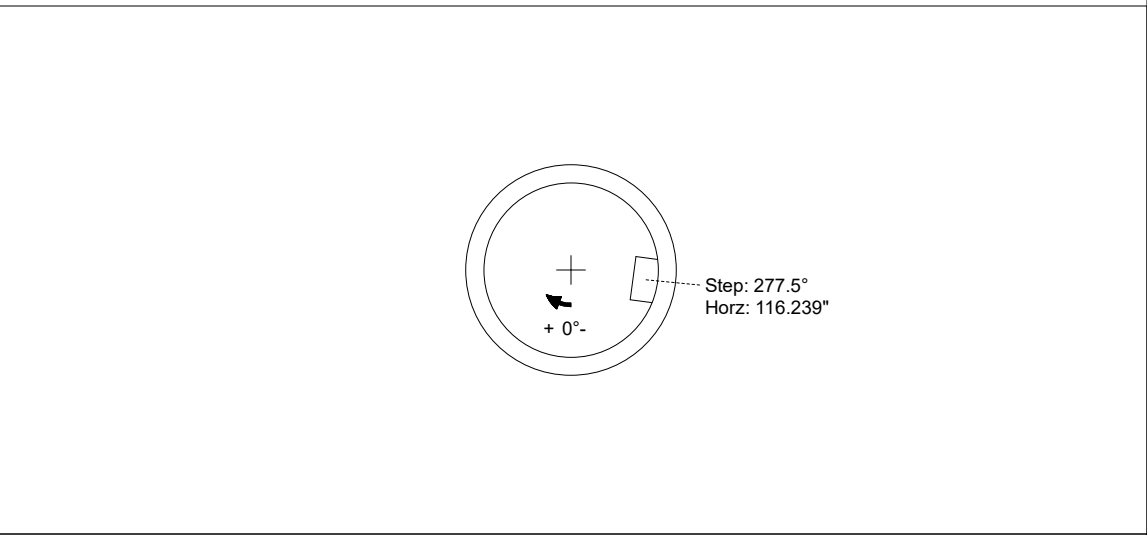
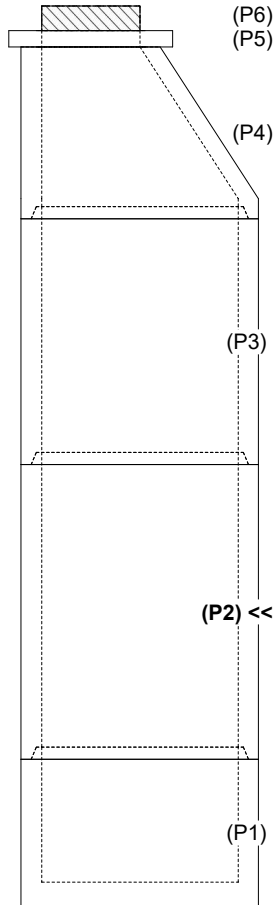

INSIDE WALL DIMENSIONS

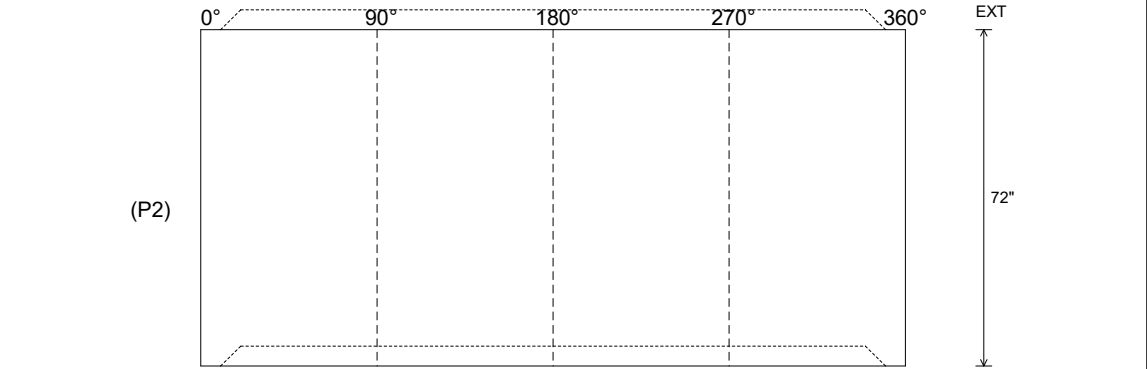

Coating (Int): Coating (Ext):	Seam Up: Tongue Seam Dn: Groove	Wall Thickness: 5" Floor Height: 0"	Height (Int): 72" Height (Ext): 72"	Weight (Net): 5030 lb Volume (Net): 1.28cu.yd
----------------------------------	------------------------------------	----------------------------------------	----------------------------------------	--------------------------------------------------