

Job Name: 26-1191 - Red River Ridge Ph 4 Sanitary  
 Job Location: Clarksville, TN  
 Contractor: Byard Construction, LLC

Plant: 100

Tech: J. Horsley

2/18/2026 2:52:54 PM

PC: A. Chambers



**Structure ID: MH 1-11-10 SS-MH**

**P1 MH048BA30CDARED**

**MH BASE w/ConBlock-CDA Red T/n**

- P5) 24" - CASTING HEIGHT - 6" 0 lb
  - P4) 24" - GRADE RING w/ConBlock-CDA Red F/F - 4" 270 lb
  - P3) 48" - ECC CONE w/ 24" HOLE, w/ConBlock-CDA Red F/G - 30" 1961 lb
  - P2) 48" - MH RISER w/ConBlock-CDA Red T/G - 60" 4192 lb
  - P1) 48" - MH BASE w/ConBlock-CDA Red T/n - 30" 3309 lb
  - 1) 48" - MH INVERT CHANNEL w/ConBlock-CDA Red - FULL HEIGHT 1440 lb
  - 1) ADMIXTURE CONBLOCK CDA RED 0 lb
  - 1) JOINT WRAP - 0.065"x6"x50" CONSEAL CS212 0 lb
  - 1) JOINT WRAP PRIMER - CONSEAL CS-75 (1 gal.) 0 lb
  - 1) CASTING - JBS 1155 F/C SANITARY 250 lb
  - 2) 48" - Conseal CS-102 1.00" (Double) 0 lb
  - 2) PSX - 12-08 NYLO 16 lb
  - 1) PSX - 8QRS-S NYLO 6 lb
  - 10) MH Step ML-10-TDS-NCR - 10" 0 lb
- Structure Total: 11444 lb

- Structure Notes:**
1. PER ASTM C-478 SPECIFICATIONS
  2. CONCRETE: 4,000 PSI AT 28 DAYS
  3. REINFORCEMENT: PER ASTM A615
  4. INVERT CHANNEL REQUIRED
  5. CONBLOCK CDA RED ADMIXTURE REQUIRED
  6. STEPS AT 68.5 DEGREES
  7. JBS 1155 FRAME & COVER "SANITARY" SUPPLIED BY ICAST

Rim: 484.91' Rim to Invert: 10.71' Slack: 0.52" Sump: 2" Step Position: 68.5°

| Position | Elev   | Angle | Ext. (cw) | Pipe         | Pipe OD | Connector       | Hole | Horz Size | Up ( ) | Offset |
|----------|--------|-------|-----------|--------------|---------|-----------------|------|-----------|--------|--------|
| Invert 1 | 474.2' | 0°    | 0"        | 8" PVC SDR35 | 8.5"    | PSX 12-08 NYLO  | 12"  | 12.129"   | 0"     | 0"     |
| Invert 2 | 474.4' | 137°  | 69.342"   | 4" PVC SDR35 | 4.25"   | PSX 8QRS-S NYLO | 8"   | 8.038"    | 2.4"   | 0"     |
| Invert 3 | 474.4' | 260°  | 131.598"  | 8" PVC SDR26 | 8.5"    | PSX 12-08 NYLO  | 12"  | 12.129"   | 2.4"   | 0"     |
| Invert 4 |        |       |           |              |         |                 |      |           |        |        |
| Invert 5 |        |       |           |              |         |                 |      |           |        |        |
| Invert 6 |        |       |           |              |         |                 |      |           |        |        |
| Invert 7 |        |       |           |              |         |                 |      |           |        |        |
| Invert 8 |        |       |           |              |         |                 |      |           |        |        |

RIGHT-SIDE UP VIEW (int. dimensions)

UPSIDE-DOWN VIEW (int. dimensions)

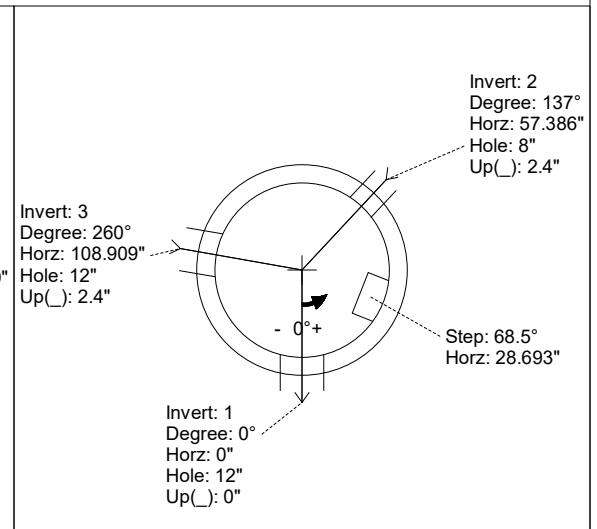
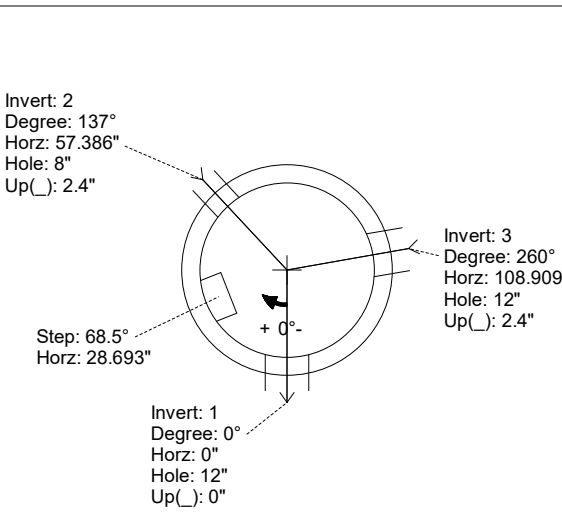
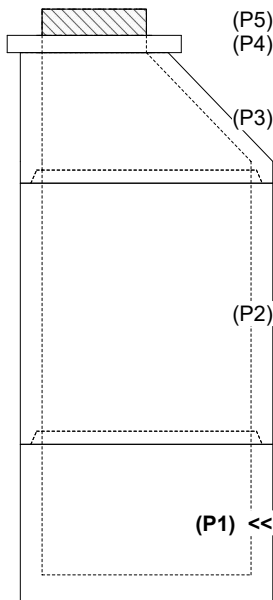

INSIDE WALL DIMENSIONS

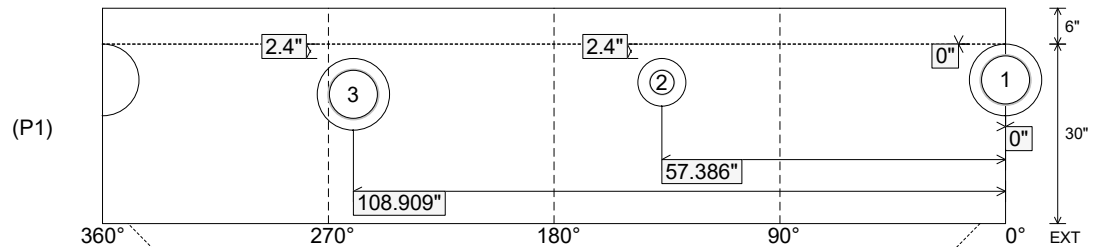

Coating (Int):  
Coating (Ext):

Seam Up: Tongue  
Seam Dn: n/a

Wall Thickness: 5"  
Floor Height: 6"

Height (Int): 30"  
Height (Ext): 36"

Weight (Net): 3309 lb  
Volume (Net): 0.84cu.yd

Job Name: 26-1191 - Red River Ridge Ph 4 Sanitary  
 Job Location: Clarksville, TN  
 Contractor: Byard Construction, LLC

Plant: 100

Tech: J. Horsley

2/18/2026 2:52:54 PM

PC: A. Chambers



**Structure ID: MH 1-11-10 SS-MH**

**P1 MH048BA30CDARED**

**MH BASE w/ConBlock-CDA Red T/n**

- P5) 24" - CASTING HEIGHT - 6" 0 lb
  - P4) 24" - GRADE RING w/ConBlock-CDA Red F/F - 4" 270 lb
  - P3) 48" - ECC CONE w/ 24" HOLE, w/ConBlock-CDA Red F/G - 30" 1961 lb
  - P2) 48" - MH RISER w/ConBlock-CDA Red T/G - 60" 4192 lb
  - P1) 48" - MH BASE w/ConBlock-CDA Red T/n - 30" 3309 lb
  - 1) 48" - MH INVERT CHANNEL w/ConBlock-CDA Red - FULL HEIGHT 1440 lb
  - 1) ADMIXTURE CONBLOCK CDA RED 0 lb
  - 1) JOINT WRAP - 0.065"x6"x50" CONSEAL CS212 0 lb
  - 1) JOINT WRAP PRIMER - CONSEAL CS-75 (1 gal.) 0 lb
  - 1) CASTING - JBS 1155 F/C SANITARY 250 lb
  - 2) 48" - Conseal CS-102 1.00" (Double) 0 lb
  - 2) PSX - 12-08 NYLO 16 lb
  - 1) PSX - 8QRS-S NYLO 6 lb
  - 10) MH Step ML-10-TDS-NCR - 10" 0 lb
- Structure Total: 11444 lb

- Structure Notes:**
1. PER ASTM C-478 SPECIFICATIONS
  2. CONCRETE: 4,000 PSI AT 28 DAYS
  3. REINFORCEMENT: PER ASTM A615
  4. INVERT CHANNEL REQUIRED
  5. CONBLOCK CDA RED ADMIXTURE REQUIRED
  6. STEPS AT 68.5 DEGREES
  7. JBS 1155 FRAME & COVER "SANITARY" SUPPLIED BY ICAST

Rim: 484.91' Rim to Invert: 10.71' Slack: 0.52" Sump: 2" Step Position: 68.5°

| Position | Elev   | Angle | Ext. (cw) | Pipe         | Pipe OD | Connector       | Hole | Horz Size | Up ( ) | Offset |
|----------|--------|-------|-----------|--------------|---------|-----------------|------|-----------|--------|--------|
| Invert 1 | 474.2' | 0°    | 0"        | 8" PVC SDR35 | 8.5"    | PSX 12-08 NYLO  | 12"  | 12.129"   | 0"     | 0"     |
| Invert 2 | 474.4' | 137°  | 69.342"   | 4" PVC SDR35 | 4.25"   | PSX 8QRS-S NYLO | 8"   | 8.038"    | 2.4"   | 0"     |
| Invert 3 | 474.4' | 260°  | 131.598"  | 8" PVC SDR26 | 8.5"    | PSX 12-08 NYLO  | 12"  | 12.129"   | 2.4"   | 0"     |
| Invert 4 |        |       |           |              |         |                 |      |           |        |        |
| Invert 5 |        |       |           |              |         |                 |      |           |        |        |
| Invert 6 |        |       |           |              |         |                 |      |           |        |        |
| Invert 7 |        |       |           |              |         |                 |      |           |        |        |
| Invert 8 |        |       |           |              |         |                 |      |           |        |        |

RIGHT-SIDE UP VIEW (int. dimensions)

UPSIDE-DOWN VIEW (int. dimensions)

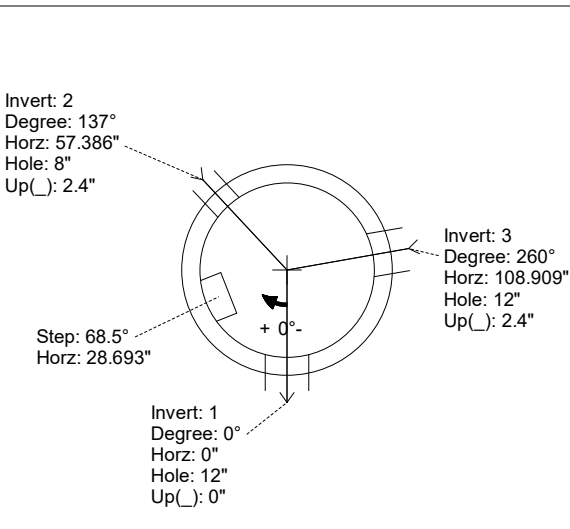
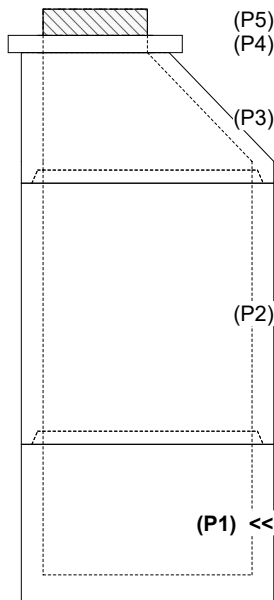

**INVERT CHANNEL DRAWING**

INSIDE WALL DIMENSIONS

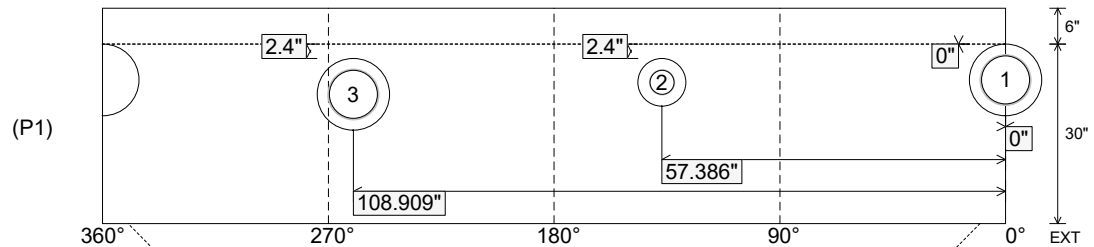

Coating (Int):  
 Coating (Ext):

Seam Up: Tongue  
 Seam Dn: n/a

Wall Thickness: 5"  
 Floor Height: 6"

Height (Int): 30"  
 Height (Ext): 36"

Weight (Net): 3309 lb  
 Volume (Net): 0.84cu.yd