

Job Name: 26-1191 - Red River Ridge Ph 4 Sanitary
 Job Location: Clarksville, TN
 Contractor: Byard Construction, LLC

Plant: 100

Tech: J. Horsley

2/18/2026 2:52:53 PM

PC: A. Chambers



Structure ID: MH 1-10-9 SS-MH

P1 MH048BA24CDARED

MH BASE w/ConBlock-CDA Red T/n

P5) 24" - CASTING HEIGHT - 6"	0 lb
P4) 24" - GRADE RING w/ConBlock-CDA Red F/F - 3"	202 lb
P3) 48" - ECC CONE w/ 24" HOLE, w/ConBlock-CDA Red F/G - 30"	1961 lb
P2) 48" - MH RISER w/ConBlock-CDA Red T/G - 48"	3353 lb
P1) 48" - MH BASE w/ConBlock-CDA Red T/n - 24"	2911 lb
1) 48" - MH INVERT CHANNEL w/ConBlock-CDA Red - FULL HEIGHT	1440 lb
1) ADMIXTURE CONBLOCK CDA RED	0 lb
1) JOINT WRAP - 0.065"x6"x50" CONSEAL CS212	0 lb
1) JOINT WRAP PRIMER - CONSEAL CS-75 (1 gal.)	0 lb
1) CASTING - JBS 1155 F/C SANITARY	250 lb
2) 48" - Conseal CS-102 1.00" (Double)	0 lb
2) PSX - 12-08 NYLO	16 lb
9) MH Step ML-10-TDS-NCR - 10"	0 lb
Structure Total:	10134 lb

- Structure Notes:**
1. PER ASTM C-478 SPECIFICATIONS
 2. CONCRETE: 4,000 PSI AT 28 DAYS
 3. REINFORCEMENT: PER ASTM A615
 4. INVERT CHANNEL REQUIRED
 5. CONBLOCK CDA RED ADMIXTURE REQUIRED
 6. STEPS AT 96 DEGREES
 7. JBS 1155 FRAME & COVER "SANITARY" SUPPLIED BY ICAST

Rim: 482" Rim to Invert: 9.3" Slack: 2.6" Sump: 2" Step Position: 96°

Position	Elev	Angle	Ext. (cw)	Pipe	Pipe OD	Connector	Hole	Horz Size	Up ()	Offset
Invert 1	472.7'	0°	0"	8" PVC SDR26	8.5"	PSX 12-08 NYLO	12"	12.129"	0"	0"
Invert 2	472.9'	192°	97.18"	8" PVC SDR35	8.5"	PSX 12-08 NYLO	12"	12.129"	2.4"	0"
Invert 3										
Invert 4										
Invert 5										
Invert 6										
Invert 7										
Invert 8										

RIGHT-SIDE UP VIEW (int. dimensions)

UPSIDE-DOWN VIEW (int. dimensions)

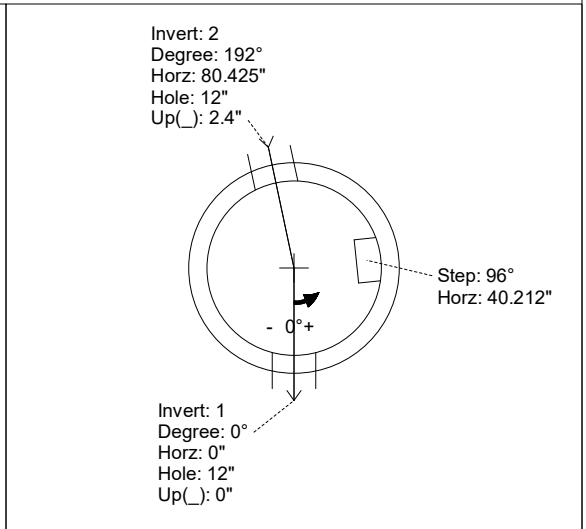
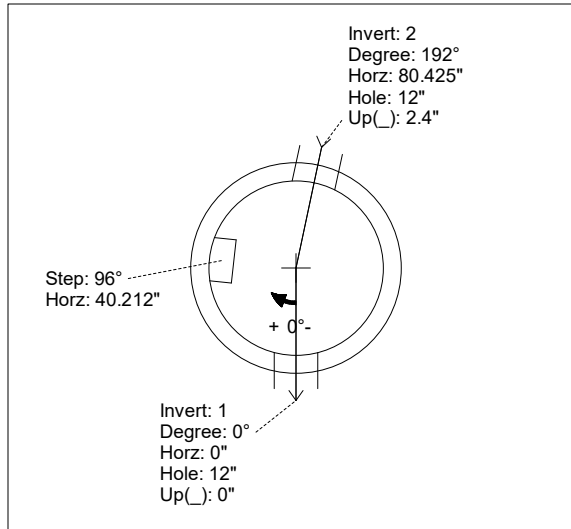
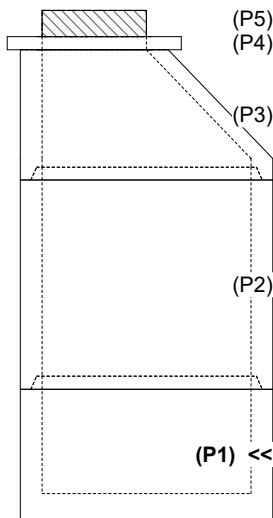

INSIDE WALL DIMENSIONS

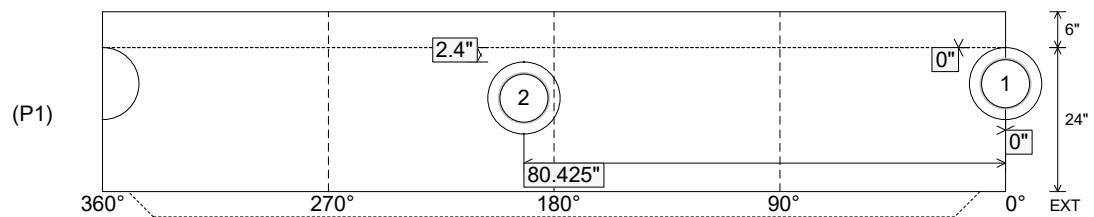

Coating (Int):
Coating (Ext):

Seam Up: Tongue
Seam Dn: n/a

Wall Thickness: 5"
Floor Height: 6"

Height (Int): 24"
Height (Ext): 30"

Weight (Net): 2911 lb
Volume (Net): 0.74cu.yd

Job Name: 26-1191 - Red River Ridge Ph 4 Sanitary
 Job Location: Clarksville, TN
 Contractor: Byard Construction, LLC

Plant: 100

Tech: J. Horsley

2/18/2026 2:52:53 PM

PC: A. Chambers



Structure ID: MH 1-10-9 SS-MH

P1 MH048BA24CDARED

MH BASE w/ConBlock-CDA Red T/n

P5) 24" - CASTING HEIGHT - 6"	0 lb
P4) 24" - GRADE RING w/ConBlock-CDA Red F/F - 3"	202 lb
P3) 48" - ECC CONE w/ 24" HOLE, w/ConBlock-CDA Red F/G - 30"	1961 lb
P2) 48" - MH RISER w/ConBlock-CDA Red T/G - 48"	3353 lb
P1) 48" - MH BASE w/ConBlock-CDA Red T/n - 24"	2911 lb
1) 48" - MH INVERT CHANNEL w/ConBlock-CDA Red - FULL HEIGHT	1440 lb
1) ADMIXTURE CONBLOCK CDA RED	0 lb
1) JOINT WRAP - 0.065"x6"x50" CONSEAL CS212	0 lb
1) JOINT WRAP PRIMER - CONSEAL CS-75 (1 gal.)	0 lb
1) CASTING - JBS 1155 F/C SANITARY	250 lb
2) 48" - Conseal CS-102 1.00" (Double)	0 lb
2) PSX - 12-08 NYLO	16 lb
9) MH Step ML-10-TDS-NCR - 10"	0 lb
Structure Total:	10134 lb

- Structure Notes:**
1. PER ASTM C-478 SPECIFICATIONS
 2. CONCRETE: 4,000 PSI AT 28 DAYS
 3. REINFORCEMENT: PER ASTM A615
 4. INVERT CHANNEL REQUIRED
 5. CONBLOCK CDA RED ADMIXTURE REQUIRED
 6. STEPS AT 96 DEGREES
 7. JBS 1155 FRAME & COVER "SANITARY" SUPPLIED BY ICAST

Rim: 482' Rim to Invert: 9.3' Slack: 2.6" Sump: 2" Step Position: 96°

Position	Elev	Angle	Ext. (cw)	Pipe	Pipe OD	Connector	Hole	Horz Size	Up ()	Offset
Invert 1	472.7'	0°	0"	8" PVC SDR26	8.5"	PSX 12-08 NYLO	12"	12.129"	0"	0"
Invert 2	472.9'	192°	97.18"	8" PVC SDR35	8.5"	PSX 12-08 NYLO	12"	12.129"	2.4"	0"
Invert 3										
Invert 4										
Invert 5										
Invert 6										
Invert 7										
Invert 8										

RIGHT-SIDE UP VIEW (int. dimensions)

UPSIDE-DOWN VIEW (int. dimensions)

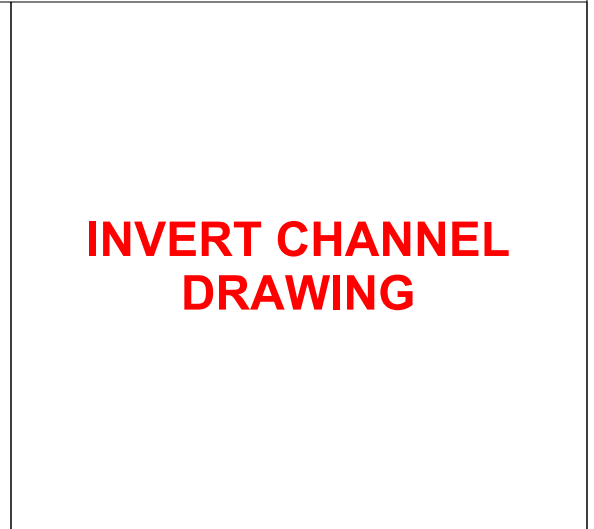
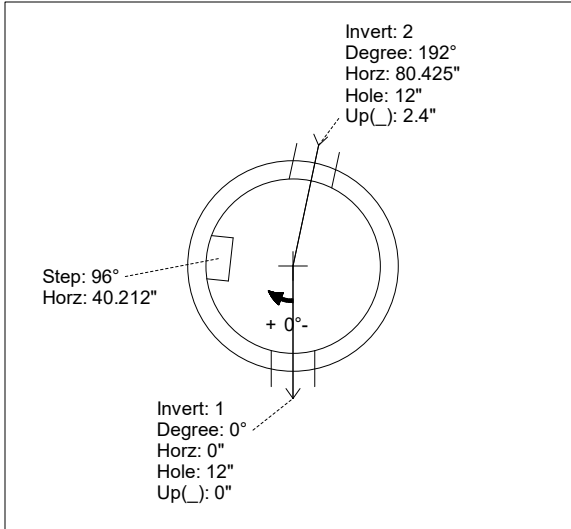
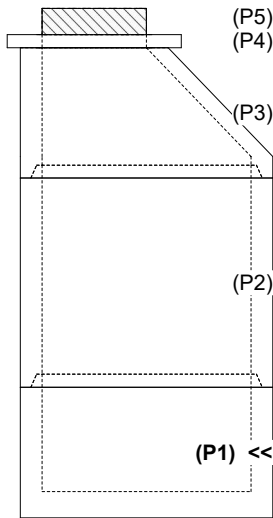

INSIDE WALL DIMENSIONS

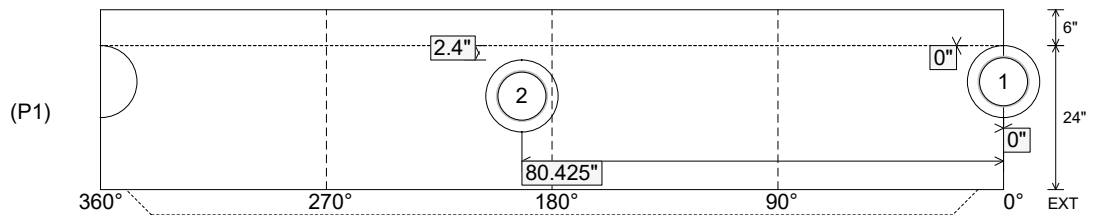

Coating (Int):
Coating (Ext):

Seam Up: Tongue
Seam Dn: n/a

Wall Thickness: 5"
Floor Height: 6"

Height (Int): 24"
Height (Ext): 30"

Weight (Net): 2911 lb
Volume (Net): 0.74cu.yd