

GENERAL NOTES:

1. MANUFACTURED PER ASTM C-913 (LATEST REVISION)
2. CONCRETE: 4,500 PSI AT 28 DAYS
3. REINFORCEMENT:
- TOP SLAB: #4 BAR @ 6" C.C. E.W. (GRADE 60)
- BASE: #4 BAR @ 6" C.C. E.W. (GRADE 60)
4. JOINT SEALED WITH CONCRETE SEALANTS CS-102 - MEETS ASTM C-990 SPECIFICATIONS (SUPPLIED BY ICAST)
5. HOE MCS-288 FRAME & COVER "STORM" SUPPLIED BY ICAST - FRAME TO BE CAST INTO TOP SLAB FLANGE SIDE UP
6. WEIGHTS:
- 6" TOP SLAB: 1,905 LBS
- 38" BASE: 7,520 LBS
7. 3/4" HDPE WEIR, 3/4" HDPE BAFFLE, & STAINLESS STEEL HOODED SCREEN SUPPLIED BY OTHERS
8. 2" X 2" X 64" LONG BULL NOSE METAL ANGLE W/ 3 EA. 4" NELSON STUDS SUPPLIED BY ICAST - CAST INTO STREET SIDE TOP EDGE OF TOP SLAB
9. SPECIAL PRE-ASSEMBLY OF INTERNALS BY ICAST

2" X 2" X 64" LONG BULL NOSE METAL ANGLE W/ 3 EA. 4" NELSON STUDS CAST INTO STREET SIDE TOP EDGE OF TOP SLAB

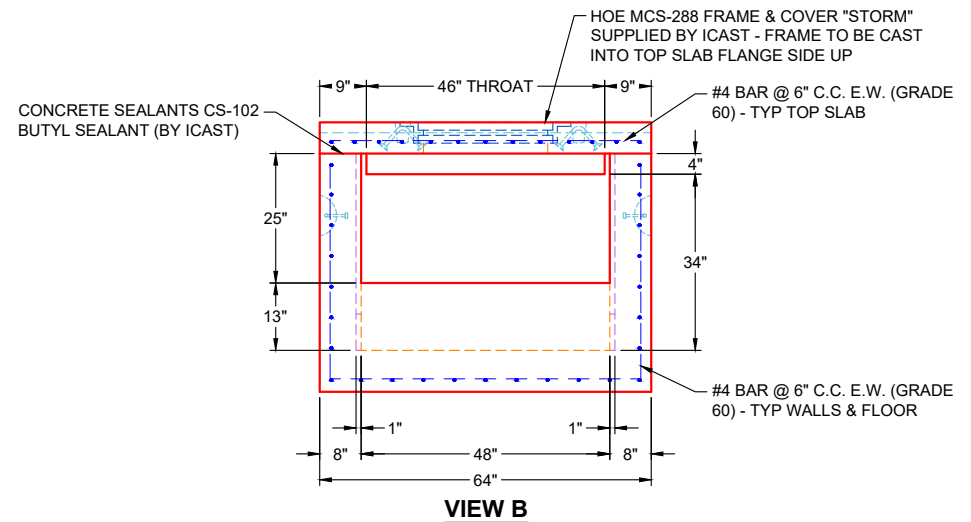
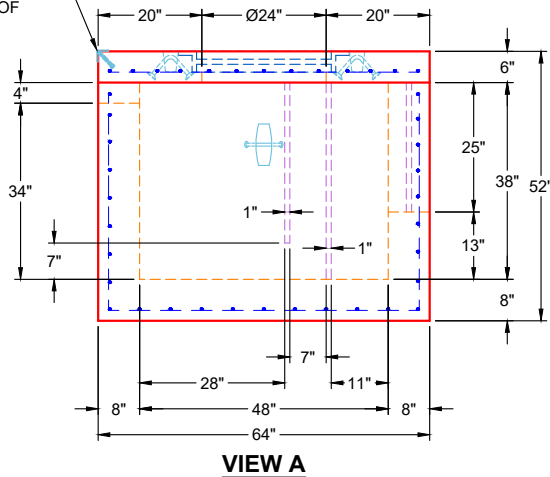

REVISION INFORMATION

REV. DATE: NO REVISIONS TO DATE



SUBMITTAL DRAWING: 48" X 48" PRETX CURB INLET

CUSTOMER: CONVERGENT WATER TECHNOLOGIES

PROJECT: WAWA 7009 PRETX

STRUCTURE: PRETX-CURB 2A-4 ST-CI

QUOTE/SALES ORDER NO: 26-1189

CHECKED BY: B. SMITH

DRAWN BY: K. CARDWELL

DATE: 01/30/26

SCALE: NTS

PG. 1 OF 1