

Job Name: 26-1162 - Youngstown Sewer Replacement
 Job Location: Jeffersonville, IN 47130
 Contractor: SLB Pipe Solutions

Plant: 100
 3/12/2026 4:19:18 PM

Tech: J. Horsley - F
 PC: T. Lewis



Structure ID: S2 (3)

P1 MH048BAVF

MH BASE Custom Ht T/n

P4) 24" - CASTING HEIGHT - 7"	0 lb
P3) 48" - ECC CONE w/ 24" HOLE F/G - 36"	3000 lb
P2) 48" - MH RISER T/G - 36"	2515 lb
P1) 48" - MH BASE Custom Ht T/n - 21"	2701 lb
1) JOINT WRAP - 0.065"x6"x50' CONSEAL CS212	0 lb
1) JOINT WRAP PRIMER - CONSEAL CS-75 (1 gal.)	0 lb
1) 48" - MH INVERT CHANNEL - FULL HEIGHT	1440 lb
1) CASTING - HOE MC-375 F/C Sanitary	271 lb
2) 48" - Conseal CS-102 1.00" (Double)	0 lb
2) PSX - 12-08 NYLO	16 lb
Structure Total:	9943 lb

Structure Notes:
 1. PER ASTM C478 SPECIFICATIONS.
 2. CONCRETE = 4,000 PSI AT 28 DAYS.
 3. CASTING BY ICAST (HOE MC-375 F/C SANITARY)
 4. NO STEPS.

 REINFORCING PER ASTM A615 (GRADE 60).
 - CONE (As .12)
 - RISER/WALLS (As .12)
 - FLOOR (As .31) #5 BARS AT 12" C.C.E.W.

Rim: 455.73' Rim to Invert: 8.11' Slack: 0.32" Sump: 3" Step Position:

Position	Elev	Angle	Ext. (cw)	Pipe	Pipe OD	Connector	Hole	Horz Size	Up ()	Offset
Invert 1	447.62'	0°	0"	8" PVC SDR35	8.5"	PSX 12-08 NYLO	12"	12.129"	1"	0"
Invert 2	447.72'	180°	91.125"	8" PVC SDR35	8.5"	PSX 12-08 NYLO	12"	12.129"	2.25"	0"
Invert 3										
Invert 4										
Invert 5										
Invert 6										
Invert 7										
Invert 8										

RIGHT-SIDE UP VIEW (int. dimensions)

UPSIDE-DOWN VIEW (int. dimensions)

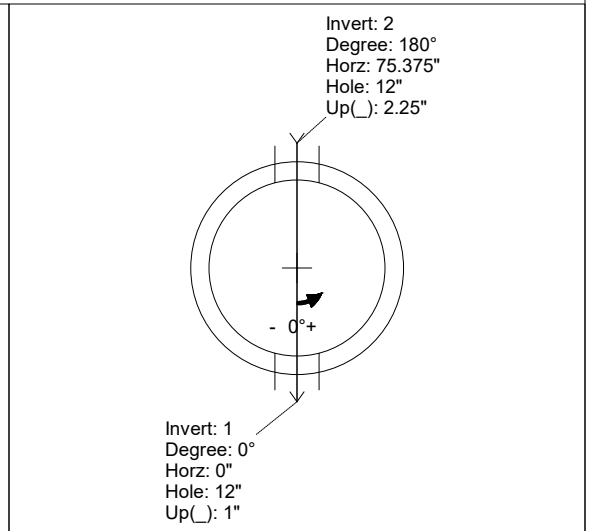
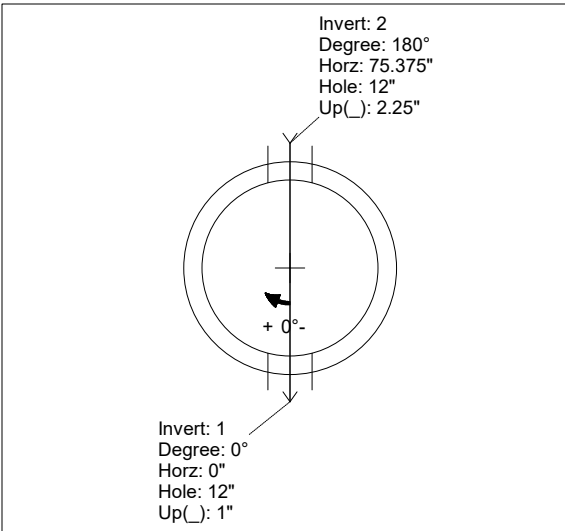
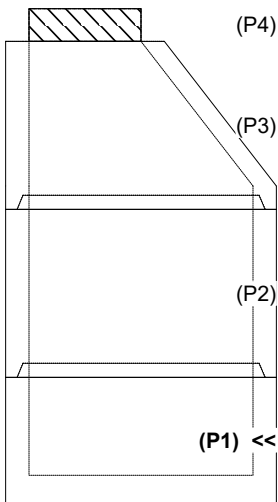

INSIDE WALL DIMENSIONS

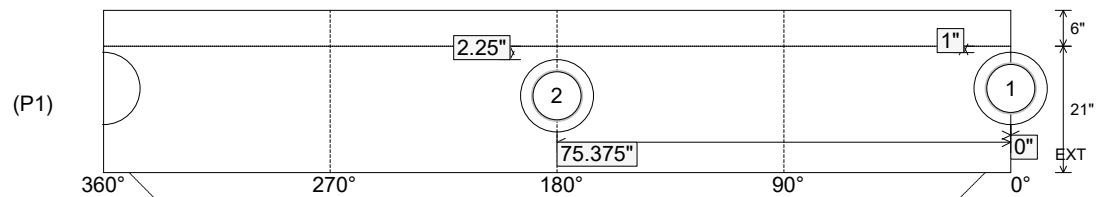

Coating (Int): Coating (Ext):	Seam Up: Tongue Seam Dn: n/a	Wall Thickness: 5" Floor Height: 6"	Height (Int): 21" Height (Ext): 27"	Weight (Net): 2701 lb Volume (Net): 0.69cu.yd
----------------------------------	---------------------------------	--	--	--

Job Name: 26-1162 - Youngstown Sewer Replacement
 Job Location: Jeffersonville, IN 47130
 Contractor: SLB Pipe Solutions

Plant: 100
 3/12/2026 4:19:18 PM

Tech: J. Horsley - F
 PC: T. Lewis



Structure ID: S2 (3)

P1 MH048BAVF

MH BASE Custom Ht T/n

- P4) 24" - CASTING HEIGHT - 7"
- P3) 48" - ECC CONE w/ 24" HOLE F/G - 36"
- P2) 48" - MH RISER T/G - 36"
- P1) 48" - MH BASE Custom Ht T/n - 21"
- 1) JOINT WRAP - 0.065"x6"x50' CONSEAL CS212
- 1) JOINT WRAP PRIMER - CONSEAL CS-75 (1 gal.)
- 1) 48" - MH INVERT CHANNEL - FULL HEIGHT**
- 1) CASTING - HOE MC-375 F/C Sanitary
- 2) 48" - Conseal CS-102 1.00" (Double)
- 2) PSX - 12-08 NYLO

0 lb
 3000 lb
 2515 lb
 2701 lb
 0 lb
 0 lb
 1440 lb
 271 lb
 0 lb
 16 lb

 Structure Total: 9943 lb

- Structure Notes:**
1. PER ASTM C478 SPECIFICATIONS.
 2. CONCRETE = 4,000 PSI AT 28 DAYS.
 3. CASTING BY ICAST (HOE MC-375 F/C SANITARY)
 4. NO STEPS.

REINFORCING PER ASTM A615 (GRADE 60).
 - CONE (As .12)
 - RISER/WALLS (As .12)
 - FLOOR (As .31) #5 BARS AT 12" C.C.E.W.

Rim: 455.73' Rim to Invert: 8.11' Slack: 0.32" Sump: 3" Step Position:

Position	Elev	Angle	Ext. (cw)	Pipe	Pipe OD	Connector	Hole	Horz Size	Up ()	Offset
Invert 1	447.62'	0°	0"	8" PVC SDR35	8.5"	PSX 12-08 NYLO	12"	12.129"	1"	0"
Invert 2	447.72'	180°	91.125"	8" PVC SDR35	8.5"	PSX 12-08 NYLO	12"	12.129"	2.25"	0"
Invert 3										
Invert 4										
Invert 5										
Invert 6										
Invert 7										
Invert 8										

RIGHT-SIDE UP VIEW (int. dimensions)

UPSIDE-DOWN VIEW (int. dimensions)

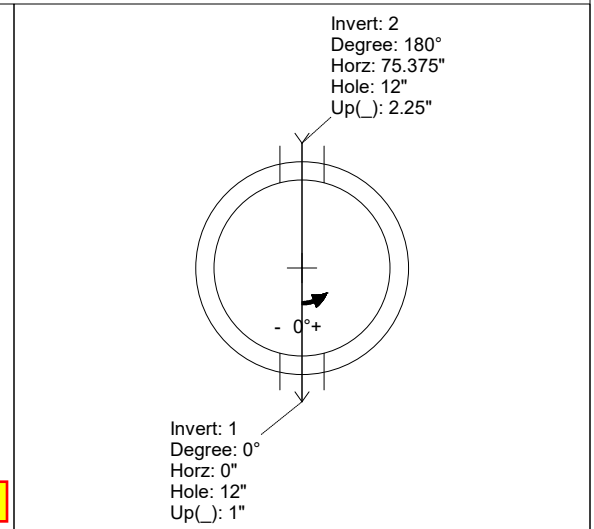
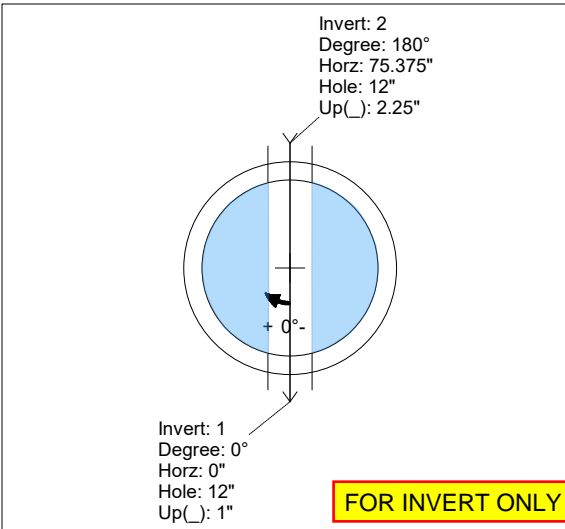
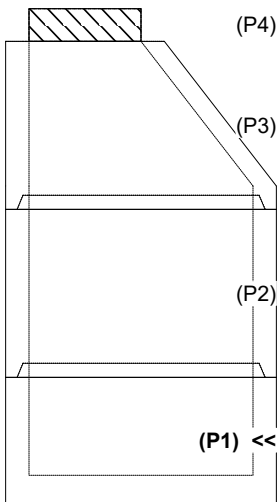

INSIDE WALL DIMENSIONS

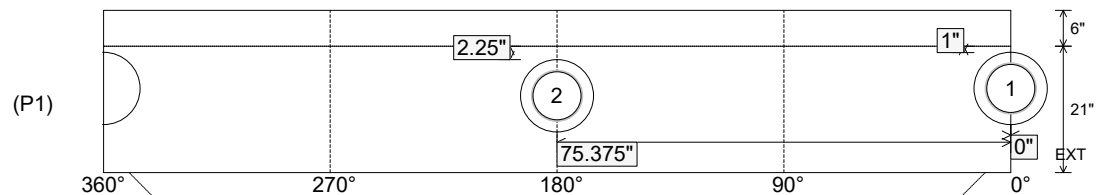

Coating (Int):
 Coating (Ext):

Seam Up: Tongue
 Seam Dn: n/a

Wall Thickness: 5"
 Floor Height: 6"

Height (Int): 21"
 Height (Ext): 27"

Weight (Net): 2701 lb
 Volume (Net): 0.69cu.yd