

Job Name: 26-1141 - KYTC Warren Co (261106)
 Job Location: Bowling Green, KY
 Contractor: Mick-Murf Construction Inc.

Plant: 100
 3/17/2026 4:01:14 PM

Tech: Jared - F
 PC: C. Goff



Structure ID: B01 (32)

P1 BX2460-08BAVF

BOX BASE 8inW, 8inF, Variable Ht F/n

- P5) 8" x 120" - CB INLET KY B 10' TOP - 9"
- P4) 24" x 120" - CB INLET KY B 10' BOTTOM SAG - 17"
- P3) 24" x 24" - BOX RISER 8inW - 18"
- P2) 24" x 60" - CB FT REDUCER 24"X24" HOLE - 8"
- P1) 24" x 60" - BOX BASE 8inW, 8inF, Variable Ht - 65"
- 1) SECONDARY POUR - Walls
- 1) 24" x 60" - Conseal CS-102 1.00"
- 2) 24" x 24" - Conseal CS-102 1.00"
- 1) Hole - 52
- 1) Hole - 18
- 1) Hole - 28

1660 lb
 2650 lb
 1547 lb
 1654 lb
 8758 lb
 0 lb
 0 lb
 0 lb
 0 lb
 0 lb
 0 lb

Structure Notes:

- ** KYTC STATE PROJECT **
- 1. PER KYTC CBI TYPE B / ASTM C913 SPEC'S.
- 2. CONCRETE = 4,000 PSI AT 28 DAYS.
- 3. CASTING SUPPLIED BY OTHERS (HOE KY-345 SET (CBI B)).

REINFORCING PER ASTM A615 (GRADE 60).

- TOP PHASE (As .62) #5 BARS AT 6" C.C.E.W.
- WALLS (As .31) #5 BARS AT 12" C.C.E.W.
- TRANS. SLAB (As .62) #5 BARS AT 6" C.C.E.W (DBL MAT)
- WALLS (As .31) #5 BARS AT 12" C.C.E.W.
- FLOOR (As .31) #5 BARS AT 12" C.C.E.W.

Structure Total: 16268 lb

Rim: 478' Rim to Invert: 10.09' Slack: 4.08" Sump: 0" Step Position:

Position	Elev	Angle	Ext. (cw)	Pipe	Pipe OD	Connector	Hole	Horz Size	Up ()	Offset
Invert 1	467.91'	90°	38"	48" CMP	49"	Hole 52	52"	52"	-2"	0"
Invert 2	471.3'	180°	20"	15" CMP	16"	Hole 18	18"	18"	39.125"	0"
Invert 3	467.91'	270°	38"	24" CMP	25"	Hole 28	28"	28"	-2"	0"
Invert 4										
Invert 5										
Invert 6										
Invert 7										
Invert 8										

RIGHT-SIDE UP VIEW (int. dimensions)

UPSIDE-DOWN VIEW (int. dimensions)

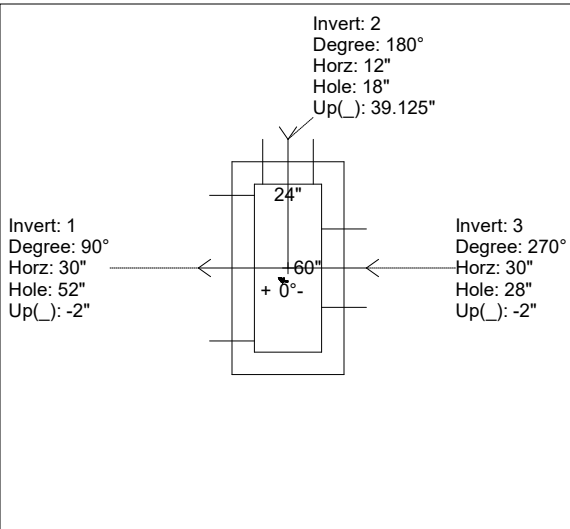
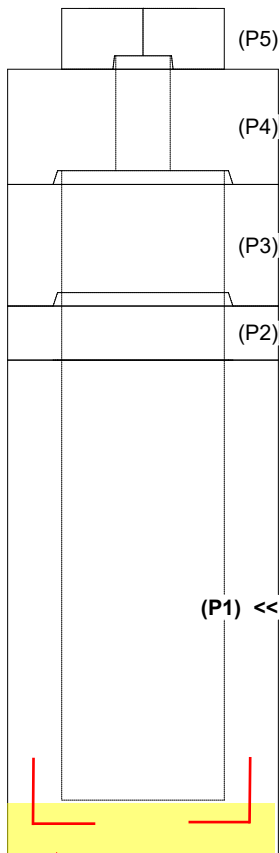

**1ST POUR (FLOOR) = 1,740 LBS
 2ND POUR (WALLS) = 6,284 LBS**

INSIDE WALL DIMENSIONS

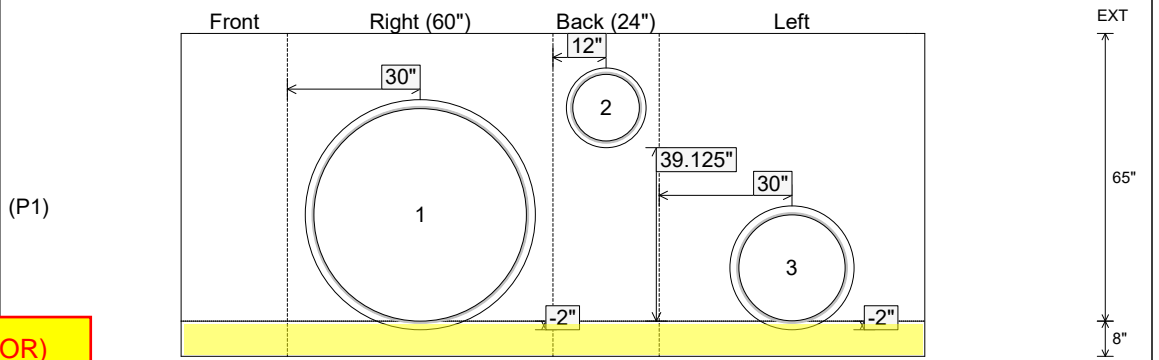

**1ST POUR (FLOOR)
 STUB #5 L BARS OUT
 TOP FLOOR, SPA AT
 12" C/C FOR
 CONNECTING WALLS**

Coating (Int):
 Coating (Ext):

Seam Up: Flat
 Seam Dn: n/a

Wall Thickness: 8"
 Floor Height: 8"

Height (Int): 65"
 Height (Ext): 73"

Weight (Net): 8758 lb
 Volume (Net): 2.24cu.yd

Job Name: 26-1141 - KYTC Warren Co (261106)
 Job Location: Bowling Green, KY
 Contractor: Mick-Murf Construction Inc.

Plant: 100
 3/17/2026 4:01:14 PM

Tech: Jared - F
 PC: C. Goff



Structure ID: B01 (32)

P1 BX2460-08BAVF

BOX BASE 8inW, 8inF, Variable Ht F/n

- P5) 8" x 120" - CB INLET KY B 10' TOP - 9"
- P4) 24" x 120" - CB INLET KY B 10' BOTTOM SAG - 17"
- P3) 24" x 24" - BOX RISER 8inW - 18"
- P2) 24" x 60" - CB FT REDUCER 24"X24" HOLE - 8"
- P1) 24" x 60" - BOX BASE 8inW, 8inF, Variable Ht - 65"
- 1) SECONDARY POUR - Walls
- 1) 24" x 60" - Conseal CS-102 1.00"
- 2) 24" x 24" - Conseal CS-102 1.00"
- 1) Hole - 52
- 1) Hole - 18
- 1) Hole - 28

1660 lb
 2650 lb
 1547 lb
 1654 lb
 8758 lb
 0 lb
 0 lb
 0 lb
 0 lb
 0 lb

Structure Notes:

- ** KYTC STATE PROJECT **
- 1. PER KYTC CBI TYPE B / ASTM C913 SPEC'S.
- 2. CONCRETE = 4,000 PSI AT 28 DAYS.
- 3. CASTING SUPPLIED BY OTHERS (HOE KY-345 SET (CBI B)).

REINFORCING PER ASTM A615 (GRADE 60).

- TOP PHASE (As .62) #5 BARS AT 6" C.C.E.W.
- WALLS (As .31) #5 BARS AT 12" C.C.E.W.
- TRANS. SLAB (As .62) #5 BARS AT 6" C.C.E.W (DBL MAT)
- WALLS (As .31) #5 BARS AT 12" C.C.E.W.
- FLOOR (As .31) #5 BARS AT 12" C.C.E.W.

Structure Total: 16268 lb

Rim: 478' Rim to Invert: 10.09' Slack: 4.08" Sump: 0" Step Position:

Position	Elev	Angle	Ext. (cw)	Pipe	Pipe OD	Connector	Hole	Horz Size	Up ()	Offset
Invert 1	467.91'	90°	38"	48" CMP	49"	Hole 52	52"	52"	-2"	0"
Invert 2	471.3'	180°	20"	15" CMP	16"	Hole 18	18"	18"	39.125"	0"
Invert 3	467.91'	270°	38"	24" CMP	25"	Hole 28	28"	28"	-2"	0"
Invert 4										
Invert 5										
Invert 6										
Invert 7										
Invert 8										

RIGHT-SIDE UP VIEW (int. dimensions)

UPSIDE-DOWN VIEW (int. dimensions)

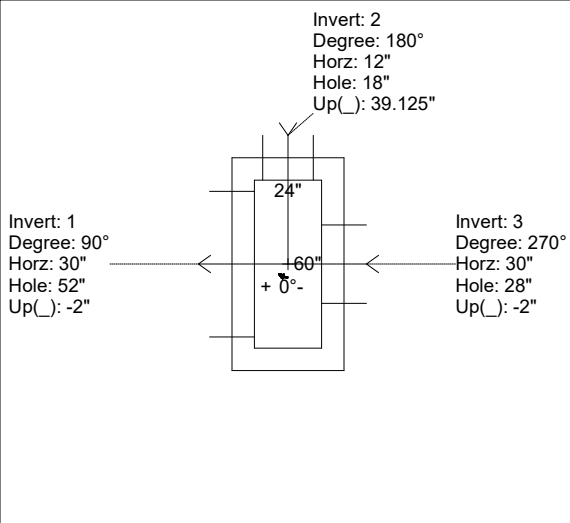
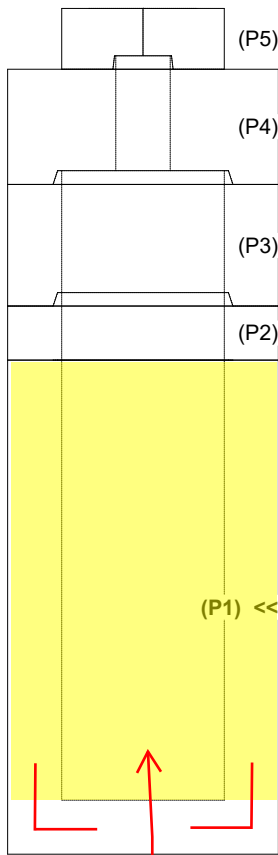

1ST POUR (FLOOR) = 1,740 LBS
 2ND POUR (WALLS) = 6,284 LBS

INSIDE WALL DIMENSIONS

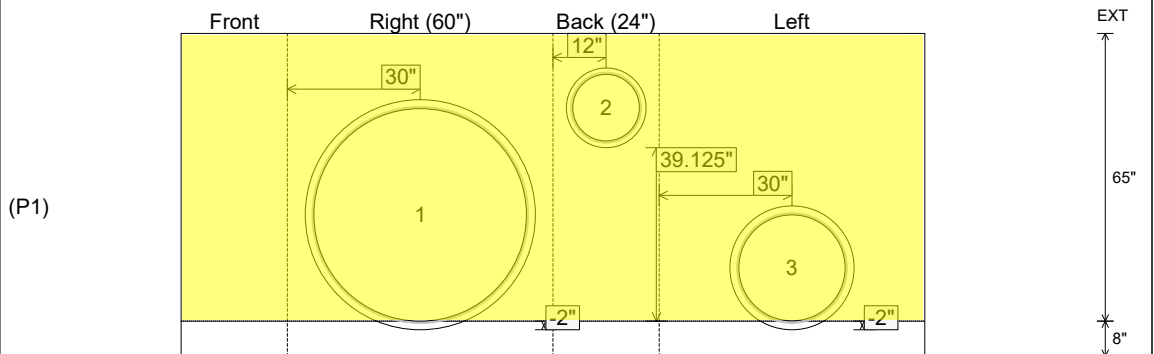

Coating (Int): Coating (Ext):	Seam Up: Flat Seam Dn: n/a	Wall Thickness: 8" Floor Height: 8"	Height (Int): 65" Height (Ext): 73"	Weight (Net): 8758 lb Volume (Net): 2.24cu.yd
----------------------------------	-------------------------------	--	--	--