

Job Name: 26-1141 - KYTC Warren Co (261106)
 Job Location: Bowling Green, KY
 Contractor: Mick-Murf Construction Inc.

Plant: 100

Tech: Jared - F

3/17/2026 4:00:53 PM

PC: C. Goff



Structure ID: A19 (6)

P1 BX2424-08BAVF

BOX BASE 8inW, 8inF, Variable Ht T/n

- P3) 8" x 120" - CB INLET KY B 10' TOP F/G - 9"
- P2) 24" x 120" - CB INLET KY B 10' BOTTOM RIGHT T/G - 17"
- P1) 24" x 24" - BOX BASE 8inW, 8inF, Variable Ht T/n - 26"
- 1) 24" x 24" - Conseal CS-102 1.00"
- 2) Hole - 18

1660 lb
 2650 lb
 2966 lb
 0 lb
 0 lb

 7276 lb

Structure Total: 7276 lb

Structure Notes:

- ** KYTC STATE PROJECT **
- 1. PER KYTC CBI TYPE B / ASTM C913 SPEC'S.
- 2. CONCRETE = 4,000 PSI AT 28 DAYS.
- 3. CASTING SUPPLIED BY OTHERS (HOE KY-345 SET (CBI B)).

REINFORCING PER ASTM A615 (GRADE 60).
 - TOP PHASE (As .62) #5 BARS AT 6" C.C.E.W.
 - WALLS (As .31) #5 BARS AT 12" C.C.E.W.
 - FLOOR (As .31) #5 BARS AT 12" C.C.E.W.

Rim: 497.44' Rim to Invert: 4.63' Slack: 3.56" Sump: 0" Step Position:

Position	Elev	Angle	Ext. (cw)	Pipe	Pipe OD	Connector	Hole	Horz Size	Up (↓)	Offset
Invert 1	492.81'	270°	20"	15" CMP	16"	Hole 18	18"	18"	-1.5"	0"
Invert 2	492.89'	90°	20"	15" CMP	16"	Hole 18	18"	18"	-0.5"	0"
Invert 3										
Invert 4										
Invert 5										
Invert 6										
Invert 7										
Invert 8										

RIGHT-SIDE UP VIEW (int. dimensions)

UPSIDE-DOWN VIEW (int. dimensions)

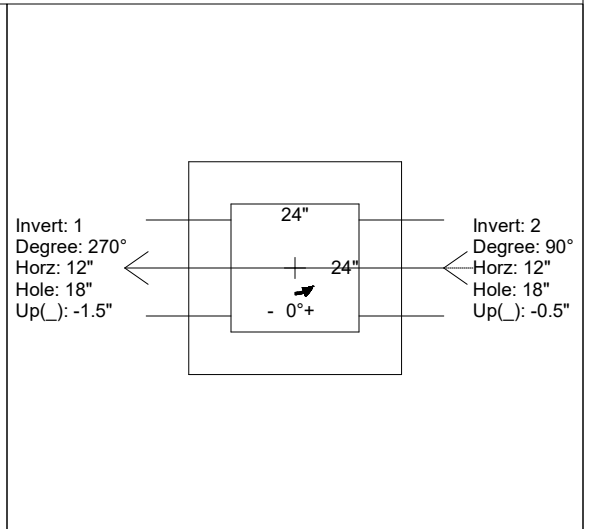
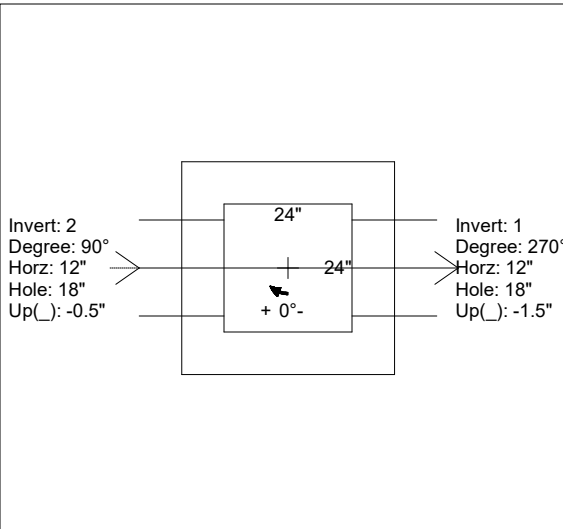
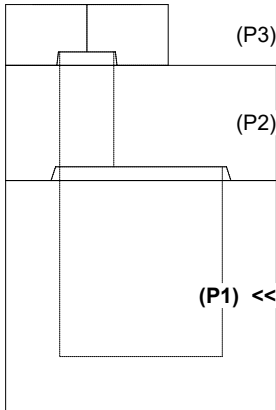

INSIDE WALL DIMENSIONS

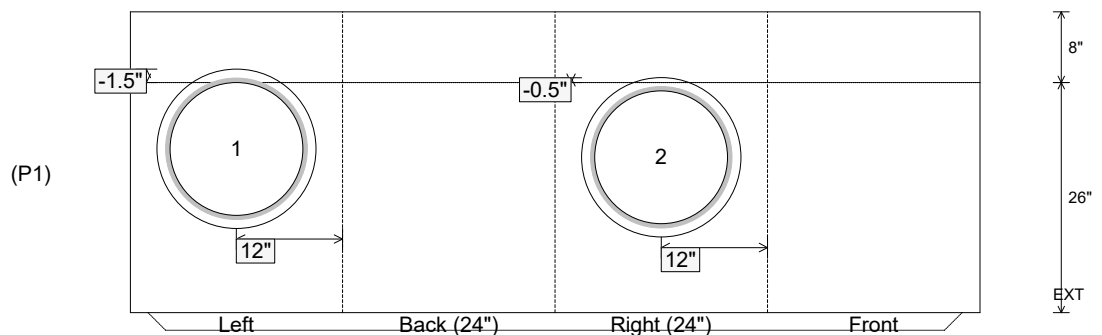

Coating (Int):
 Coating (Ext):

Seam Up: Tongue
 Seam Dn: n/a

Wall Thickness: 8"
 Floor Height: 8"

Height (Int): 26"
 Height (Ext): 34"

Weight (Net): 2966 lb
 Volume (Net): 0.76cu.yd