

Job Name: 26-1141 - KYTC Warren Co (261106)
 Job Location: Bowling Green, KY
 Contractor: Mick-Murf Construction Inc.

Plant: 100
 3/17/2026 4:01:13 PM

Tech: Jared - F
 PC: C. Goff



Structure ID: A14 (31)

P1 BX2424-08BAVF

BOX BASE 8inW, 8inF, Variable Ht T/n

- P3) 8" x 120" - CB INLET KY B 10' TOP F/G - 9"
- P2) 24" x 120" - CB INLET KY B 10' BOTTOM RIGHT T/G - 17"
- P1) 24" x 24" - BOX BASE 8inW, 8inF, Variable Ht T/n - 29"
- 1) 24" x 24" - Conseal CS-102 1.00"
- 1) Hole - 22
- 1) Hole - 18

1660 lb
 2650 lb
 3140 lb
 0 lb
 0 lb
 0 lb

 Structure Total: 7450 lb

Structure Notes:
 ** KYTC STATE PROJECT **
 1. PER KYTC CBI TYPE B / ASTM C913 SPEC'S.
 2. CONCRETE = 4,000 PSI AT 28 DAYS.
 3. CASTING SUPPLIED BY OTHERS (HOE KY-345 SET (CBI B)).

REINFORCING PER ASTM A615 (GRADE 60).
 - TOP PHASE (As .62) #5 BARS AT 6" C.C.E.W.
 - WALLS (As .31) #5 BARS AT 12" C.C.E.W.
 - FLOOR (As .31) #5 BARS AT 12" C.C.E.W.

Rim: 483.43' Rim to Invert: 4.95' Slack: 4.4" Sump: 0" Step Position:

Position	Elev	Angle	Ext. (cw)	Pipe	Pipe OD	Connector	Hole	Horz Size	Up ()	Offset
Invert 1	478.48'	270°	20"	18" CMP	19"	Hole 22	22"	22"	-2"	0"
Invert 2	478.56'	90°	20"	15" CMP	16"	Hole 18	18"	18"	-0.5"	0"
Invert 3										
Invert 4										
Invert 5										
Invert 6										
Invert 7										
Invert 8										

RIGHT-SIDE UP VIEW (int. dimensions)

UPSIDE-DOWN VIEW (int. dimensions)

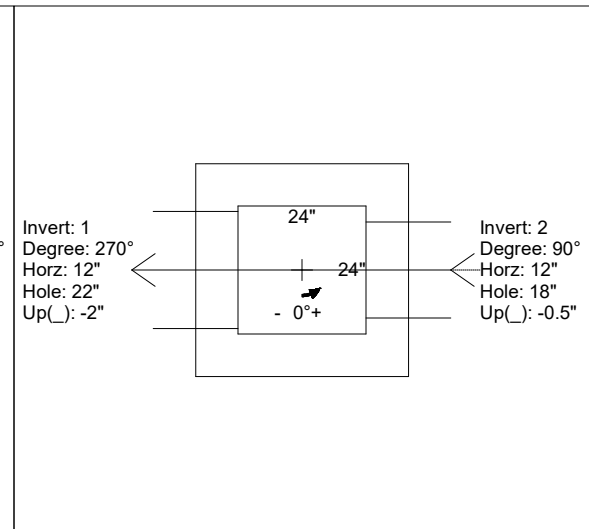
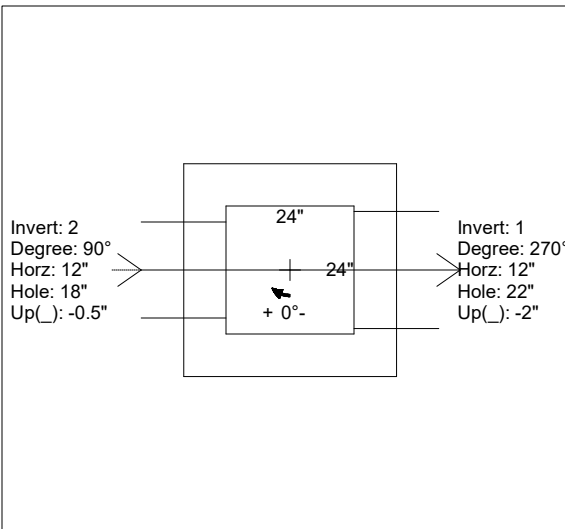
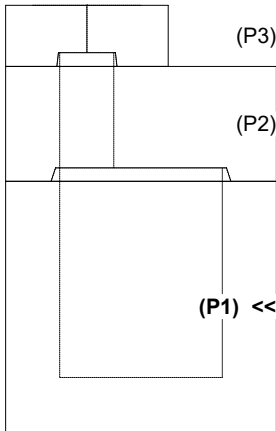

INSIDE WALL DIMENSIONS

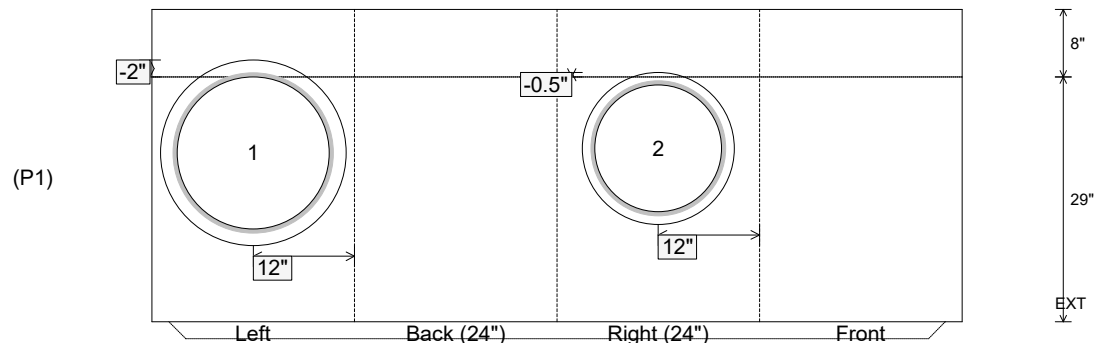

Coating (Int):
 Coating (Ext):

Seam Up: Tongue
 Seam Dn: n/a

Wall Thickness: 8"
 Floor Height: 8"

Height (Int): 29"
 Height (Ext): 37"

Weight (Net): 3140 lb
 Volume (Net): 0.8cu.yd