

Job Name: 26-1141 - KYTC Warren Co (261106)
 Job Location: Bowling Green, KY
 Contractor: Mick-Murf Construction Inc.

Plant: 100
 3/17/2026 4:01:03 PM

Tech: Jared - F
 PC: C. Goff



Structure ID: A11 (18)

P1 BX2424-08BAVF

BOX BASE 8inW, 8inF, Variable Ht F/n

P2) 24" x 24" - CASTING HEIGHT - 5"
 P1) 24" x 24" - BOX BASE 8inW, 8inF, Variable Ht F/n - 39"
 1) 24" x 24" - Conseal CS-102 1.00"
 2) Hole - 18

0 lb
 4073 lb
 0 lb
 0 lb

 Structure Total: 4073 lb

Structure Notes:
 KYTC STATE PROJECT
 1. KYTC CBI TYPE F / ASTM C913 SPECIFICATIONS.
 2. CONCRETE = 4,000 PSI AT 28 DAYS.
 3. CASTING SUPPLIED BY OTHERS (HOE KY-465 SET (CBI TY F)).

REINFORCING PER ASTM A615 (GRADE 60).
 - WALLS (As .31) #5 BARS AT 12" C.C.E.W.
 - FLOOR (As .31) #5 BARS AT 12" C.C.E.W.

Rim: 481.44' Rim to Invert: 4.04' Slack: 4.48" Sump: 0" Step Position:

Position	Elev	Angle	Ext. (cw)	Pipe	Pipe OD	Connector	Hole	Horz Size	Up ()	Offset
Invert 1	477.4'	70°	17.5"	15" CMP	16"	Hole 18	18"	19.155"	-1.5"	4.5"
Invert 2	477.4'	0°	20"	15" CMP	16"	Hole 18	18"	18"	-1.5"	0"
Invert 3										
Invert 4										
Invert 5										
Invert 6										
Invert 7										
Invert 8										

RIGHT-SIDE UP VIEW (int. dimensions)

UPSIDE-DOWN VIEW (int. dimensions)

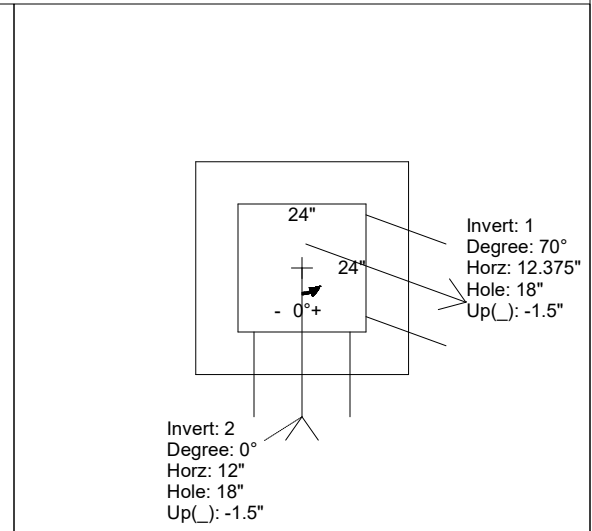
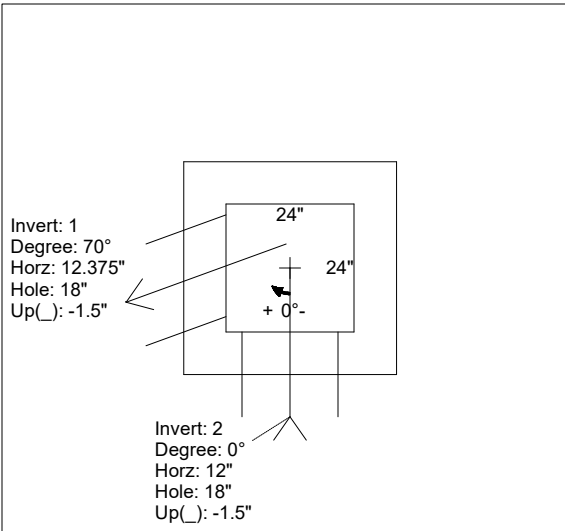
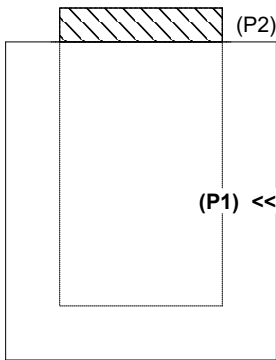

INSIDE WALL DIMENSIONS

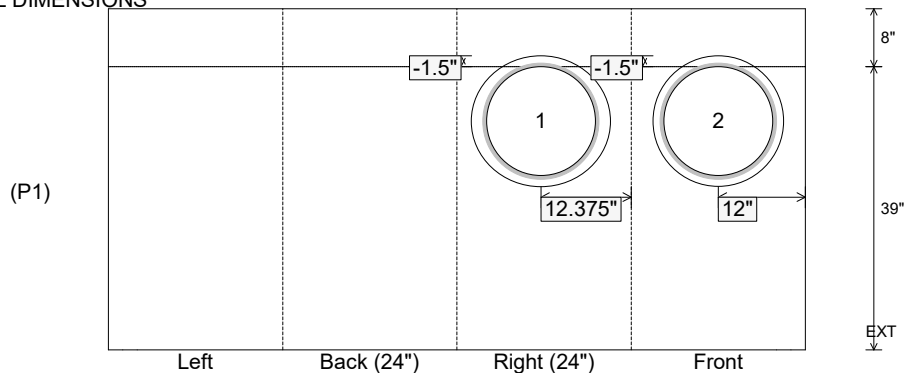

Coating (Int):
 Coating (Ext):

Seam Up: Flat
 Seam Dn: n/a

Wall Thickness: 8"
 Floor Height: 8"

Height (Int): 39"
 Height (Ext): 47"

Weight (Net): 4073 lb
 Volume (Net): 1.04cu.yd