

Job Name: 26-1077 - Westside Markets of Greensboro Village
Job Location: Gallatin, TN
Contractor: Cleary Construction, Inc.

PC: C. Goff
 TECH: J. Coppage - F
 Plant: 100



Structure ID: Z6

Spec: Sanitary
 Type: SAN.MH w/ConBlock-CDA Red
 Size: 48"

Rim: 502.7'
 Invert: 495.5'
 Rim to Invert: 7.2'

Sump: 2"
 Floor (Top): 495.333'
 Floor Height: 6"

Floor (Bot): 494.833'
 Overall Height: 7.833'
 Slack: 0.4"

Structure Notes:

1. PER ASTM C478 SPECIFICATIONS.
2. CONCRETE = 4,000 PSI AT 28 DAYS.
3. ADMIXTURE = CONBLOCK CDA RED.
4. CASTING SUPPLIED BY OTHERS (JBS 1150 F/C SANITARY).

REINFORCING PER ASTM A615 (GRADE 60).
 - CONE (As .12)
 - RISER/WALLS (As .12)
 - FLOOR (As .31) #5 BARS AT 12" C.C.E.W.

STRUCTURE SUMMARY:

P4) 24" - CASTING HEIGHT - 7"	0 lb
P3) 24" - GRADE RING w/ConBlock-CDA Red - 3"	202 lb
P2) 48" - ECC CONE w/ 24" HOLE, w/ConBlock-CDA Red - 42"	3116 lb
P1) 48" - MH BASE w/ConBlock-CDA Red - 36"	3749 lb
1) JOINT WRAP - 0.065"x6"x50' CONSEAL CS212	0 lb
1) JOINT WRAP PRIMER - CONSEAL CS-75 (1 gal.)	0 lb
1) 48" - MH INVERT CHANNEL w/ConBlock-CDA Red - FULL HEIGHT	1440 lb
1) ADMIXTURE CONBLOCK CDA RED	0 lb
1) 48" - Conseal CS-102 1.00" (Double)	0 lb
1) PSX - 12-08 NYLO	8 lb
1) PSX - 12-06 NYLO	8 lb
7) MH Step ML-10-TDS-NCR - 10"	0 lb
Structure Total:	8524 lb

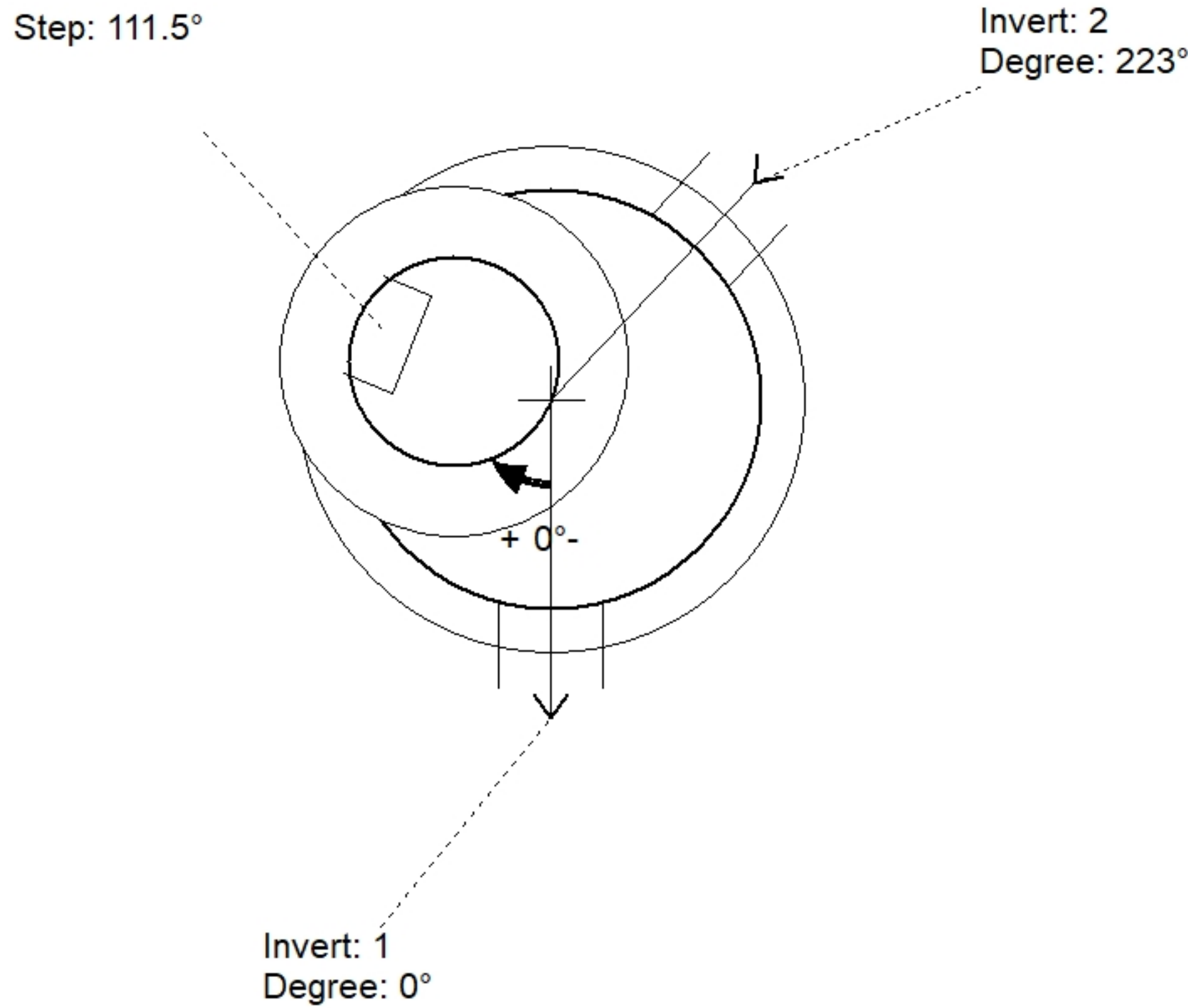

Position	Elev	Angle	Pipe	Pipe OD	Hole	Connector	Up (")	Ref
Rim	502.7'							
Reducer								
Invert 1	495.5'	0°	8" PVC SDR26	8.5"	12"	PSX 12-08 NYLO	0"	P1
Invert 2	496.32'	223°	6" PVC SDR26	6.25"	12"	PSX 12-06 NYLO	8.84"	P1
Invert 3								
Invert 4								
Invert 5								
Invert 6								
Invert 7								
Invert 8								

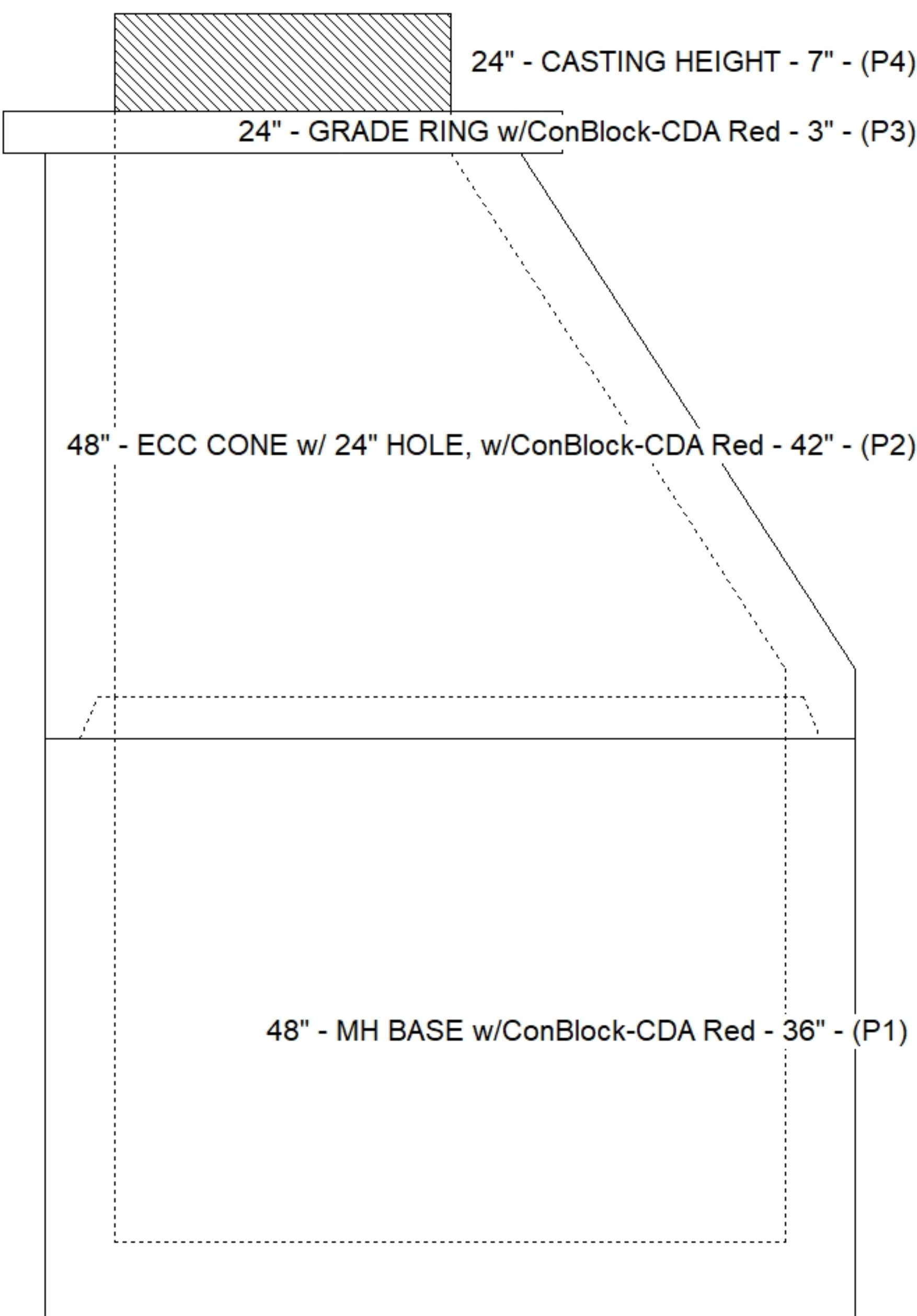

Default - Interior Dimensions

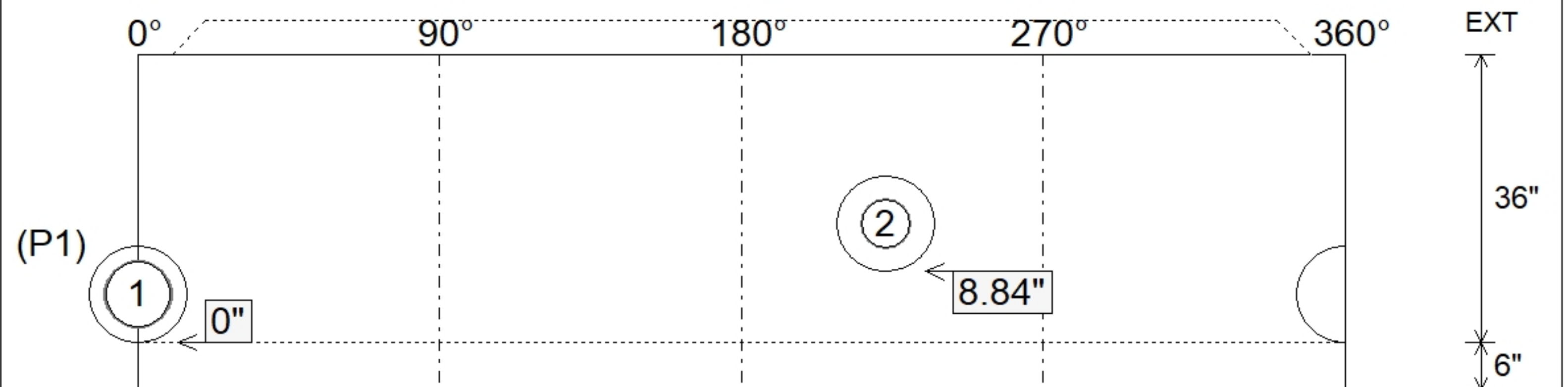

Submittal Drawing
 4/2/2026 2:59:56 PM

SUBMITTAL
 APPROVED BY: