

Job Name: 26-1077 - Westside Markets of Greensboro Village
Job Location: Gallatin, TN
Contractor: Cleary Construction, Inc.

PC: C. Goff
 TECH: J. Coppage - F
 Plant: 100



Structure ID: Z2

Spec: Sanitary
 Type: SAN.MH w/ConBlock-CDA Red
 Size: 48"

Rim: 501.28'
 Invert: 490.99'
 Rim to Invert: 10.29'

Sump: 2"
 Floor (Top): 490.823'
 Floor Height: 6"

Floor (Bot): 490.323'
 Overall Height: 10.917'
 Slack: 0.48"

Structure Notes:

- PER ASTM C478 SPECIFICATIONS.
- CONCRETE = 4,000 PSI AT 28 DAYS.
- ADMIXTURE = CONBLOCK CDA RED.
- CASTING SUPPLIED BY OTHERS (JBS 1150 F/C SANITARY).

REINFORCING PER ASTM A615 (GRADE 60).
 - CONE (As .12)
 - RISER/WALLS (As .12)
 - FLOOR (As .31) #5 BARS AT 12" C.C.E.W.

STRUCTURE SUMMARY:

| | |
|---|-----------------|
| P5) 24" - CASTING HEIGHT - 7" | 0 lb |
| P4) 24" - GRADE RING w/ConBlock-CDA Red - 4" | 270 lb |
| P3) 48" - ECC CONE w/ 24" HOLE, w/ConBlock-CDA Red - 36" | 2251 lb |
| P2) 48" - MH RISER w/ConBlock-CDA Red - 48" | 3353 lb |
| P1) 48" - MH BASE w/ConBlock-CDA Red - 30" | 3330 lb |
| 1) JOINT WRAP - 0.065"x6"x50' CONSEAL CS212 | 0 lb |
| 1) JOINT WRAP PRIMER - CONSEAL CS-75 (1 gal.) | 0 lb |
| 1) 48" - MH INVERT CHANNEL w/ConBlock-CDA Red - FULL HEIGHT | 1440 lb |
| 1) ADMIXTURE CONBLOCK CDA RED | 0 lb |
| 2) 48" - Conseal CS-102 1.00" (Double) | 0 lb |
| 2) PSX - 12-08 NYLO | 16 lb |
| 9) MH Step ML-10-TDS-NCR - 10" | 0 lb |
| Structure Total: | 10660 lb |

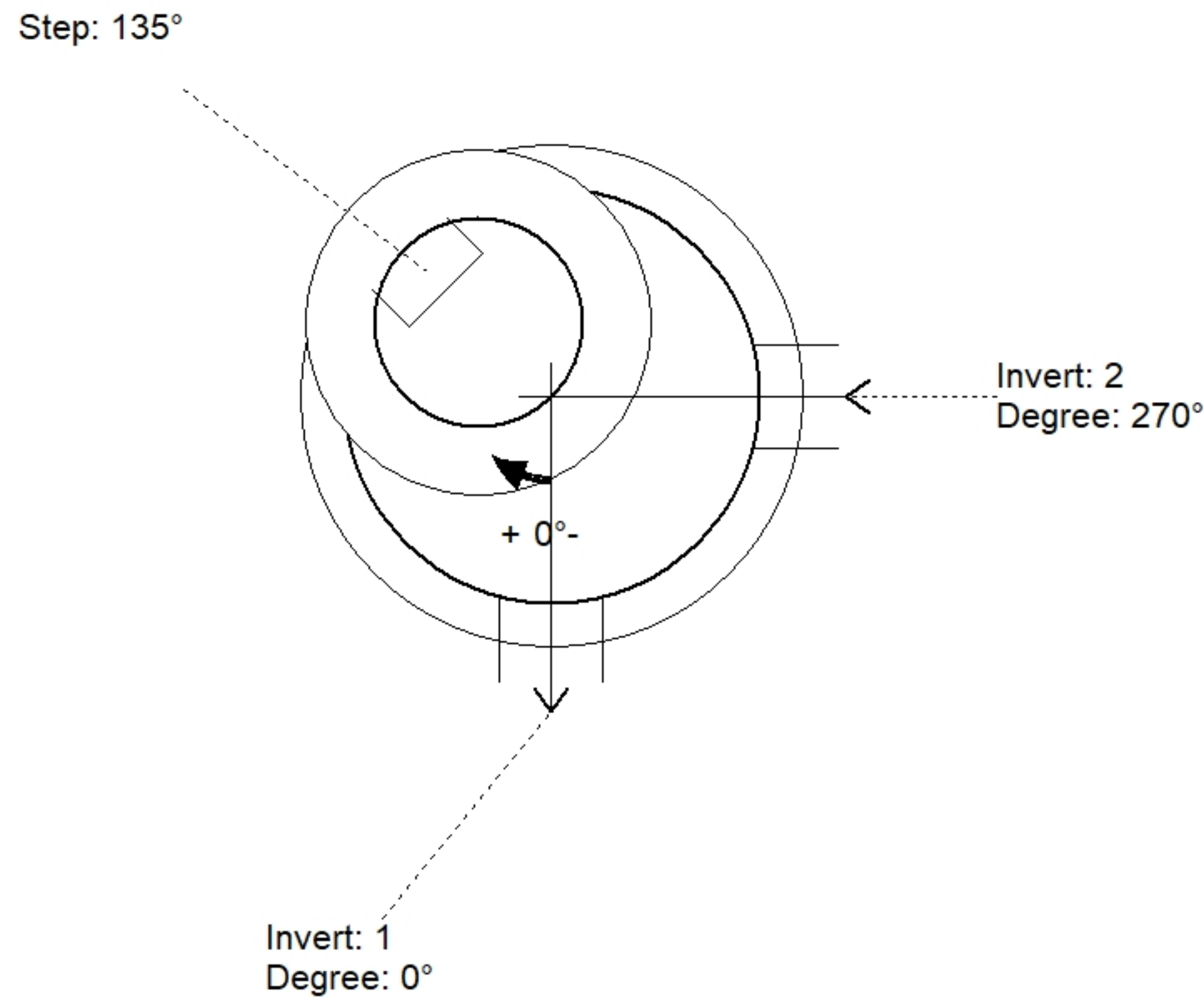

| Position | Elev | Angle | Pipe | Pipe OD | Hole | Connector | Up () | Ref |
|----------|---------|-------|--------------|---------|------|----------------|--------|-----|
| Rim | 501.28' | | | | | | | |
| Reducer | | | | | | | | |
| Invert 1 | 490.99' | 0° | 8" PVC SDR26 | 8.5" | 12" | PSX 12-08 NYLO | 0" | P1 |
| Invert 2 | 491.09' | 270° | 8" PVC SDR26 | 8.5" | 12" | PSX 12-08 NYLO | 1.2" | P1 |
| Invert 3 | | | | | | | | |
| Invert 4 | | | | | | | | |
| Invert 5 | | | | | | | | |
| Invert 6 | | | | | | | | |
| Invert 7 | | | | | | | | |
| Invert 8 | | | | | | | | |

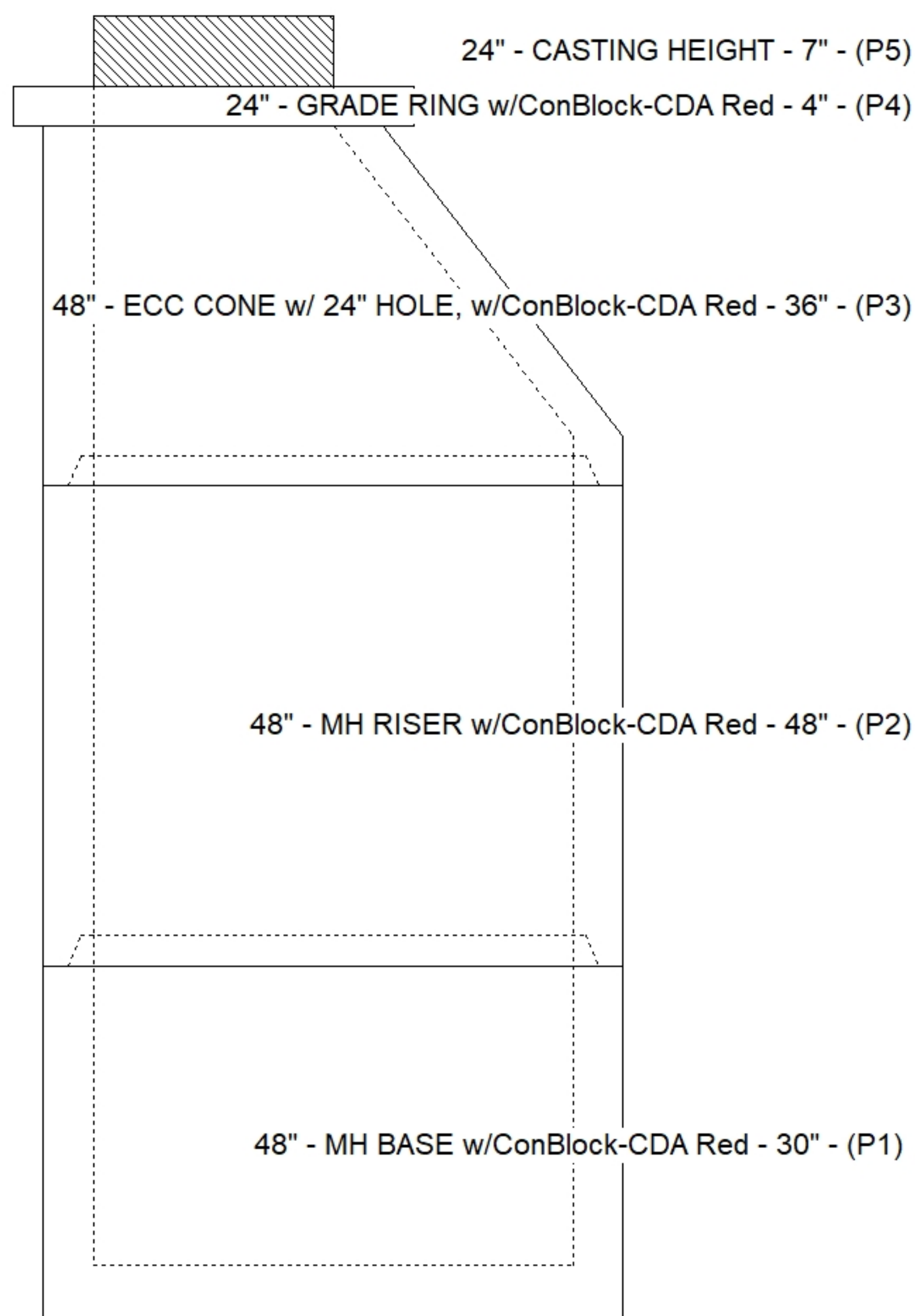

Default - Interior Dimensions

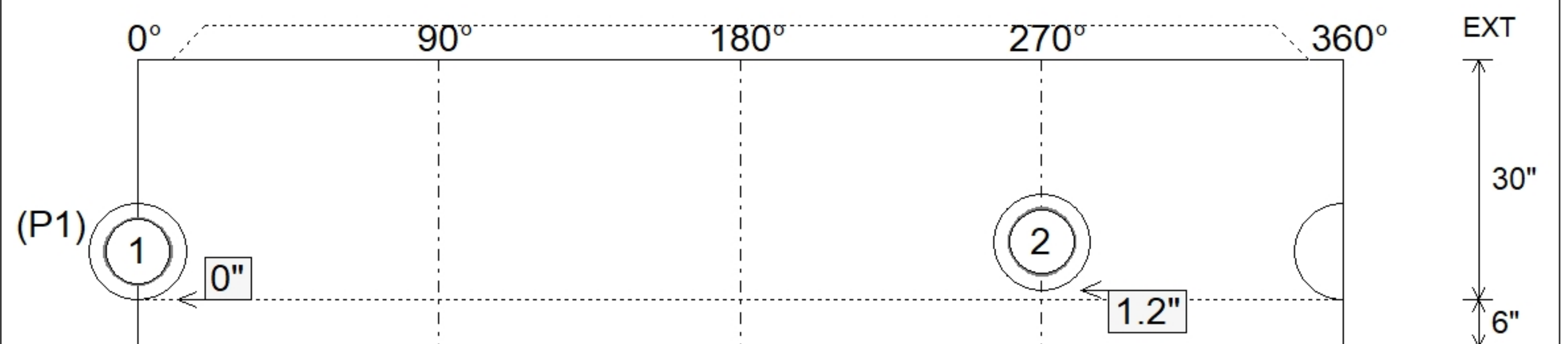

Submittal Drawing
 4/2/2026 2:59:55 PM

SUBMITTAL
 APPROVED BY: