

Job Name: 26-1077 - Westside Markets of Greensboro Village	Plant: 100	Tech: J. Horsley - F
Job Location: Gallatin, TN	3/23/2026 11:46:02 AM	PC: C. Goff
Contractor: Cleary Construction, Inc.		

Structure ID: Z1

P3 MH048CN42CDARED

ECC CONE w/ 24" HOLE, w/ConBlock-CDA Red F/G

P5) 24" - CASTING HEIGHT - 7"	0 lb	Structure Notes: 1. PER ASTM C478 SPECIFICATIONS. 2. CONCRETE = 4,000 PSI AT 28 DAYS. 3. ADMIXTURE = CONBLOCK CDA RED. 4. CASTING SUPPLIED BY OTHERS (JBS 1150 F/C SANITARY). REINFORCING PER ASTM A615 (GRADE 60). - CONE (As .12) - RISER/WALLS (As .12) - FLOOR (As .31) #5 BARS AT 12" C.C.E.W.
P4) 24" - GRADE RING w/ConBlock-CDA Red F/F - 3"	202 lb	
P3) 48" - ECC CONE w/ 24" HOLE, w/ConBlock-CDA Red F/G - 42"	3116 lb	
P2) 48" - MH RISER w/ConBlock-CDA Red T/G - 72"	5030 lb	
P1) 48" - MH BASE w/ConBlock-CDA Red T/n - 30"	3282 lb	
1) JOINT WRAP - 0.065"x6"x50' CONSEAL CS212	0 lb	
1) JOINT WRAP PRIMER - CONSEAL CS-75 (1 gal.)	0 lb	
1) 48" - MH INVERT CHANNEL w/ConBlock-CDA Red - FULL HEIGHT	1440 lb	
1) ADMIXTURE CONBLOCK CDA RED	0 lb	
2) 48" - Conseal CS-102 1.00" (Double)	0 lb	
3) PSX - 12-08 NYLO	24 lb	
12) MH Step ML-10-TDS-NCR - 10"	0 lb	

Structure Total:	13095 lb	

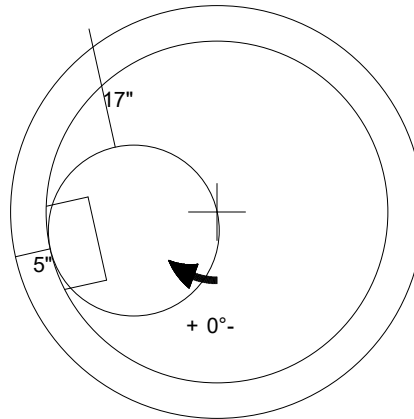

48" - ECC CONE w/ 24" HOLE, w/ConBlock-CDA Red F/G - 42" - (P3)



Coating (Int):	Seam Up: Flat	Wall Thickness: 5"	Height (Ext): 42"	Weight (Net): 3116 lb
Coating (Ext):	Seam Dn: Groove			Volume (Net): 0.8cu.yd