

Job Name: 26-1077 - Westside Markets of Greensboro Village
 Job Location: Gallatin, TN
 Contractor: Cleary Construction, Inc.

Plant: 100

Tech: J. Horsley - F

3/23/2026 11:44:15 AM

PC: C. Goff



Structure ID: X1

P1 MH048BA30CDARED

MH BASE w/ConBlock-CDA Red T/n

- P4) 24" - CASTING HEIGHT - 7" 0 lb
- P3) 48" - ECC CONE w/ 24" HOLE, w/ConBlock-CDA Red F/G - 30" 1961 lb
- P2) 48" - MH RISER w/ConBlock-CDA Red T/G - 24" 1677 lb
- P1) 48" - MH BASE w/ConBlock-CDA Red T/n - 30" 3378 lb
- 1) JOINT WRAP - 0.065"x6"x50' CONSEAL CS212 0 lb
- 1) JOINT WRAP PRIMER - CONSEAL CS-75 (1 gal.) 0 lb
- 1) 48" - MH INVERT CHANNEL w/ConBlock-CDA Red - FULL HEIGHT 1440 lb
- 1) ADMIXTURE CONBLOCK CDA RED 0 lb
- 2) 48" - Conseal CS-102 1.00" (Double) 0 lb
- 1) PSX - 12-08 NYLO 8 lb
- 7) MH Step ML-10-TDS-NCR - 10" 0 lb

Structure Total: 8464 lb

- Structure Notes:**
1. PER ASTM C478 SPECIFICATIONS.
 2. CONCRETE = 4,000 PSI AT 28 DAYS.
 3. ADMIXTURE = CONBLOCK CDA RED.
 4. CASTING SUPPLIED BY OTHERS (JBS 1150 F/C SANITARY).

- REINFORCING PER ASTM A615 (GRADE 60).**
- CONE (As .12)
 - RISER/WALLS (As .12)
 - FLOOR (As .31) #5 BARS AT 12" C.C.E.W.

Rim: 490.7' Rim to Invert: 7.5' Slack: 1" Sump: 2" Step Position: 180°

Position	Elev	Angle	Ext. (cw)	Pipe	Pipe OD	Connector	Hole	Horz Size	Up ()	Offset
Invert 1	483.2'	0°	0"	8" PVC SDR26	8.5"	PSX 12-08 NYLO	12"	12.129"	0"	0"
Invert 2										
Invert 3										
Invert 4										
Invert 5										
Invert 6										
Invert 7										
Invert 8										

RIGHT-SIDE UP VIEW (int. dimensions)

UPSIDE-DOWN VIEW (int. dimensions)

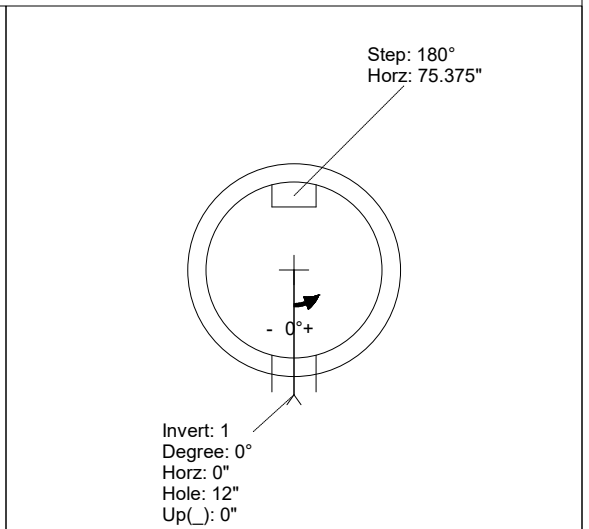
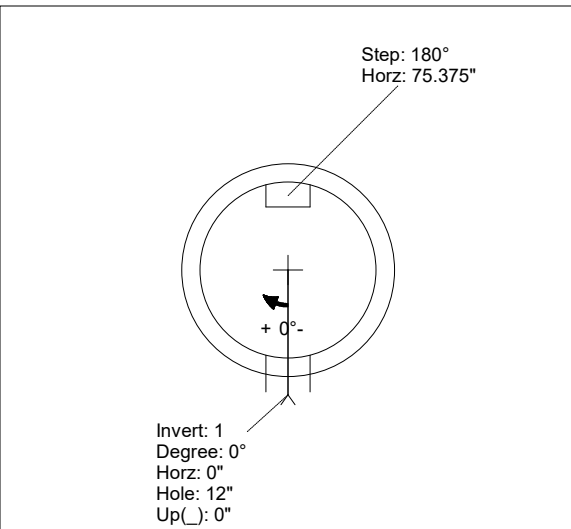
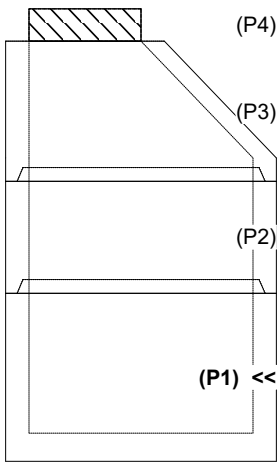

INSIDE WALL DIMENSIONS

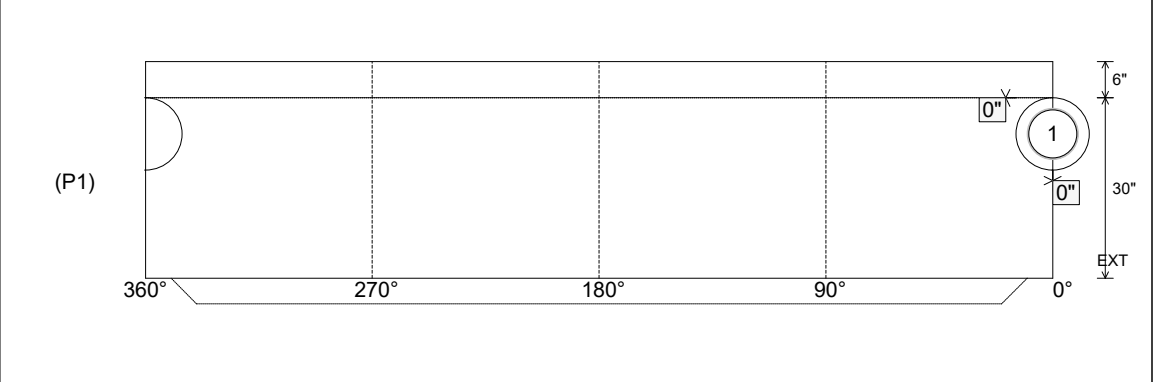

Coating (Int): Coating (Ext):	Seam Up: Tongue Seam Dn: n/a	Wall Thickness: 5" Floor Height: 6"	Height (Int): 30" Height (Ext): 36"	Weight (Net): 3378 lb Volume (Net): 0.86cu.yd
----------------------------------	---------------------------------	--	--	--

Job Name: 26-1077 - Westside Markets of Greensboro Village
 Job Location: Gallatin, TN
 Contractor: Cleary Construction, Inc.

Plant: 100

3/23/2026 11:44:15 AM

Tech: J. Horsley - F

PC: C. Goff



Structure ID: X1

P1 MH048BA30CDARED

MH BASE w/ConBlock-CDA Red T/n

- P4) 24" - CASTING HEIGHT - 7" 0 lb
- P3) 48" - ECC CONE w/ 24" HOLE, w/ConBlock-CDA Red F/G - 30" 1961 lb
- P2) 48" - MH RISER w/ConBlock-CDA Red T/G - 24" 1677 lb
- P1) 48" - MH BASE w/ConBlock-CDA Red T/n - 30" 3378 lb
- 1) JOINT WRAP - 0.065"x6"x50' CONSEAL CS212 0 lb
- 1) JOINT WRAP PRIMER - CONSEAL CS-75 (1 gal.) 0 lb
- 1) 48" - MH INVERT CHANNEL w/ConBlock-CDA Red - FULL HEIGHT 1440 lb
- 1) ADMIXTURE CONBLOCK CDA RED 0 lb
- 2) 48" - Conseal CS-102 1.00" (Double) 0 lb
- 1) PSX - 12-08 NYLO 8 lb
- 7) MH Step ML-10-TDS-NCR - 10" 0 lb

Structure Total: 8464 lb

Structure Notes:

1. PER ASTM C478 SPECIFICATIONS.
2. CONCRETE = 4,000 PSI AT 28 DAYS.
3. ADMIXTURE = CONBLOCK CDA RED.
4. CASTING SUPPLIED BY OTHERS (JBS 1150 F/C SANITARY).

REINFORCING PER ASTM A615 (GRADE 60).

- CONE (As .12)
- RISER/WALLS (As .12)
- FLOOR (As .31) #5 BARS AT 12" C.C.E.W.

Rim: 490.7' Rim to Invert: 7.5' Slack: 1" Sump: 2" Step Position: 180°

Position	Elev	Angle	Ext. (cw)	Pipe	Pipe OD	Connector	Hole	Horz Size	Up ()	Offset
Invert 1	483.2'	0°	0"	8" PVC SDR26	8.5"	PSX 12-08 NYLO	12"	12.129"	0"	0"
Invert 2										
Invert 3										
Invert 4										
Invert 5										
Invert 6										
Invert 7										
Invert 8										

RIGHT-SIDE UP VIEW (int. dimensions)

UPSIDE-DOWN VIEW (int. dimensions)

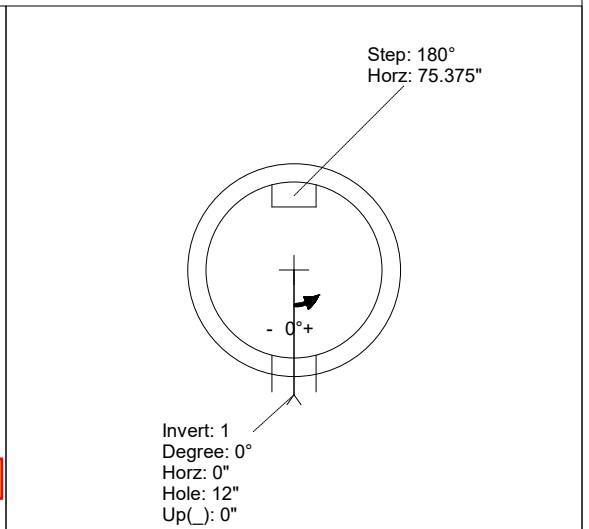
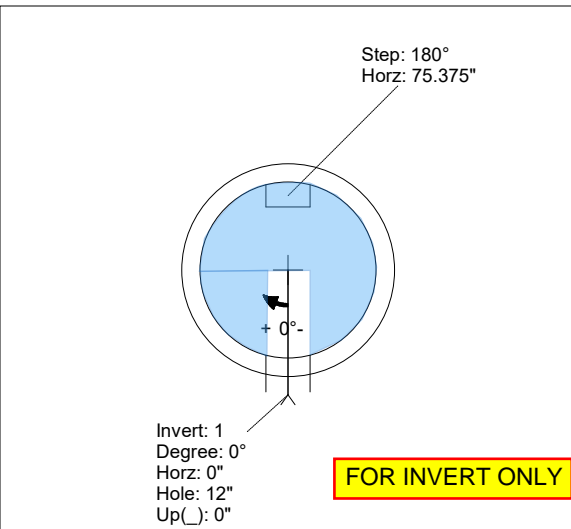
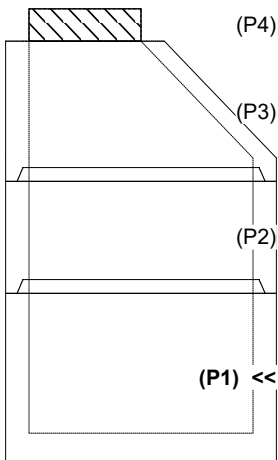

INSIDE WALL DIMENSIONS

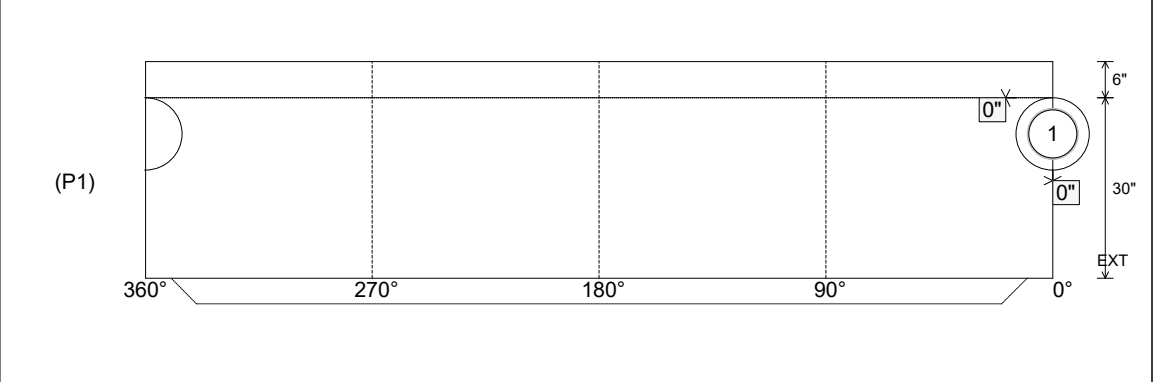

Coating (Int): Coating (Ext):	Seam Up: Tongue Seam Dn: n/a	Wall Thickness: 5" Floor Height: 6"	Height (Int): 30" Height (Ext): 36"	Weight (Net): 3378 lb Volume (Net): 0.86cu.yd
----------------------------------	---------------------------------	--	--	--