

Job Name: 26-1077 - Westside Markets of Greensboro Village
 Job Location: Gallatin, TN
 Contractor: Cleary Construction, Inc.

Plant: 100
 3/27/2026 4:33:49 PM

Tech: J. Horsley - F
 PC: C. Goff



Structure ID: G1

P1 MH060BAVF

MH BASE Custom Ht T/n

- P3) 24" - CASTING HEIGHT - 7"
- P2) 60" - MH FLAT TOP w/ 24" ECC Hole F/G - 13"
- P1) 60" - MH BASE Custom Ht T/n - 70"
- 1) 60" - STORM INVERT CHANNEL - 1/4 HEIGHT
- 1) 60" - Conseal CS-102 1.00"
- 2) Hole - 46
- 6) MH Step ML-10-TDS-NCR - 10"

0 lb
 2869 lb
 8180 lb
 1700 lb
 0 lb
 0 lb
 0 lb

 Structure Total: 12749 lb

Structure Notes:
 1. PER ASTM C478 SPECIFICATIONS.
 2. CONCRETE = 4,000 PSI AT 28 DAYS.
 3. CASTING SUPPLIED BY OTHERS (JBS 1150 F/C STORM).

REINFORCING PER ASTM A615 (GRADE 60).
 - TOP SLAB (As .62) #5 BARS AT 6" C.C.E.W..
 - RISER/WALLS (As .18)
 - FLOOR (As .37) #5 BARS AT 10" C.C.E.W.

Rim: 499.1' Rim to Invert: 7.4' Slack: 2.8" Sump: 4" Step Position: 240°

Position	Elev	Angle	Ext. (cw)	Pipe	Pipe OD	Connector	Hole	Horz Size	Up ()	Offset
Invert 1	491.7'	0°	0"	36" RCP B WALL	44"	Hole 46	46"	52.418"	0"	0"
Invert 2	492.29'	117°	73.5"	36" RCP B WALL	44"	Hole 46	46"	52.418"	7.125"	0"
Invert 3										
Invert 4										
Invert 5										
Invert 6										
Invert 7										
Invert 8										

RIGHT-SIDE UP VIEW (int. dimensions)

UPSIDE-DOWN VIEW (int. dimenions)

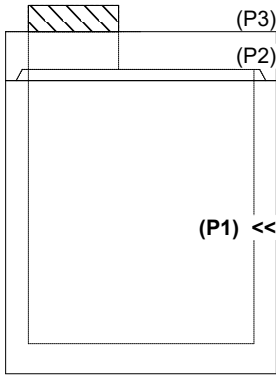
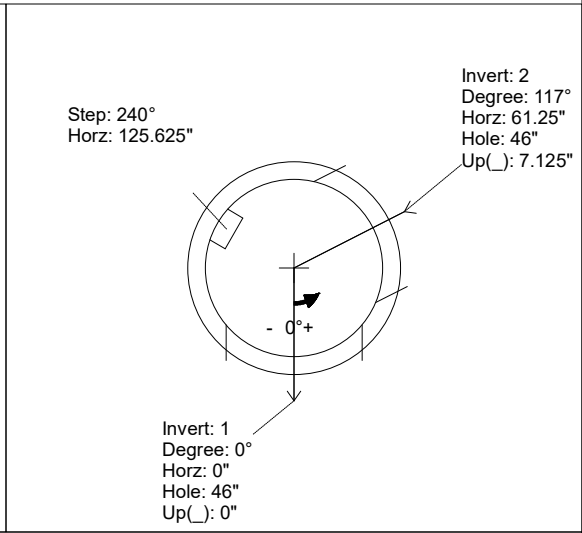
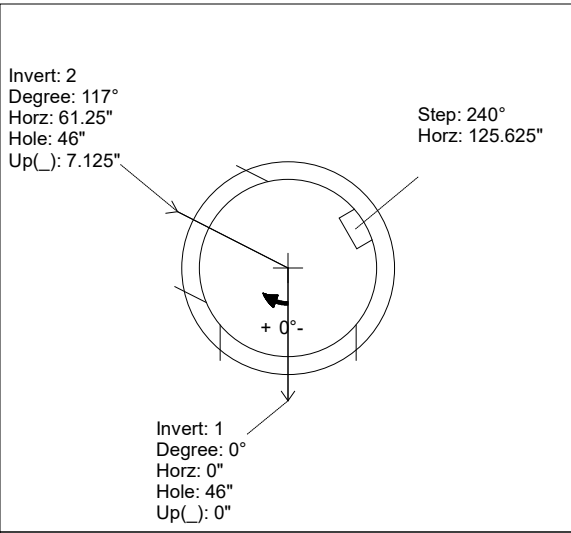

INSIDE WALL DIMENSIONS

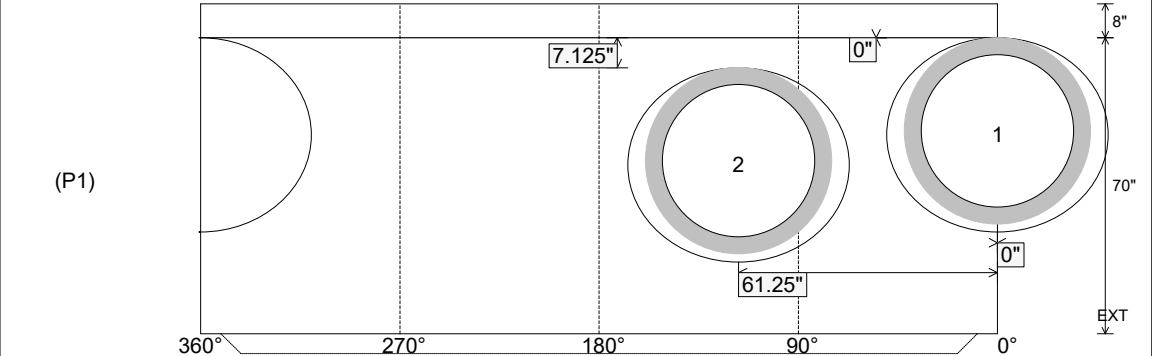

Coating (Int): Coating (Ext):	Seam Up: Tongue Seam Dn: n/a	Wall Thickness: 6" Floor Height: 8"	Height (Int): 70" Height (Ext): 78"	Weight (Net): 8180 lb Volume (Net): 2.09cu.yd
----------------------------------	---------------------------------	--	--	--

Job Name: 26-1077 - Westside Markets of Greensboro Village
 Job Location: Gallatin, TN
 Contractor: Cleary Construction, Inc.

Plant: 100
 3/27/2026 4:33:49 PM

Tech: J. Horsley - F
 PC: C. Goff



Structure ID: G1

P1 MH060BAVF

MH BASE Custom Ht T/n

- P3) 24" - CASTING HEIGHT - 7"
- P2) 60" - MH FLAT TOP w/ 24" ECC Hole F/G - 13"
- P1) 60" - MH BASE Custom Ht T/n - 70"
- 1) 60" - STORM INVERT CHANNEL - 1/4 HEIGHT
- 1) 60" - Conseal CS-102 1.00"
- 2) Hole - 46
- 6) MH Step ML-10-TDS-NCR - 10"

0 lb
 2869 lb
 8180 lb
 1700 lb
 0 lb
 0 lb
 0 lb

 Structure Total: 12749 lb

Structure Notes:
 1. PER ASTM C478 SPECIFICATIONS.
 2. CONCRETE = 4,000 PSI AT 28 DAYS.
 3. CASTING SUPPLIED BY OTHERS (JBS 1150 F/C STORM).

 REINFORCING PER ASTM A615 (GRADE 60).
 - TOP SLAB (As .62) #5 BARS AT 6" C.C.E.W..
 - RISER/WALLS (As .18)
 - FLOOR (As .37) #5 BARS AT 10" C.C.E.W.

Rim: 499.1' Rim to Invert: 7.4' Slack: 2.8" Sump: 4" Step Position: 240°

Position	Elev	Angle	Ext. (cw)	Pipe	Pipe OD	Connector	Hole	Horz Size	Up ()	Offset
Invert 1	491.7'	0°	0"	36" RCP B WALL	44"	Hole 46	46"	52.418"	0"	0"
Invert 2	492.29'	117°	73.5"	36" RCP B WALL	44"	Hole 46	46"	52.418"	7.125"	0"
Invert 3										
Invert 4										
Invert 5										
Invert 6										
Invert 7										
Invert 8										

RIGHT-SIDE UP VIEW (int. dimensions)

UPSIDE-DOWN VIEW (int. dimenions)

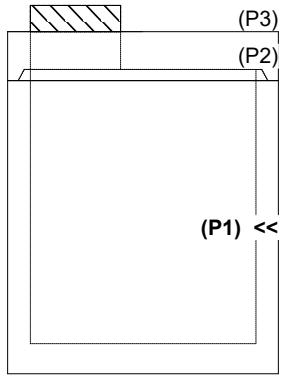
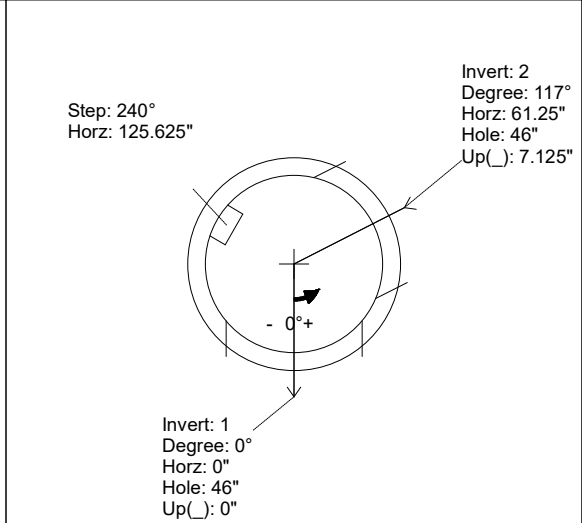
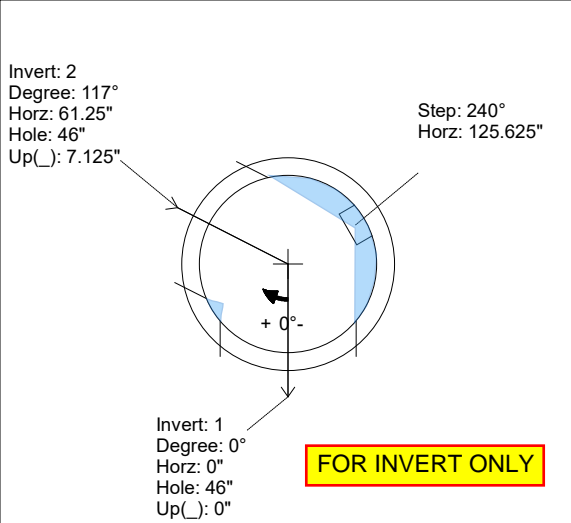

INSIDE WALL DIMENSIONS

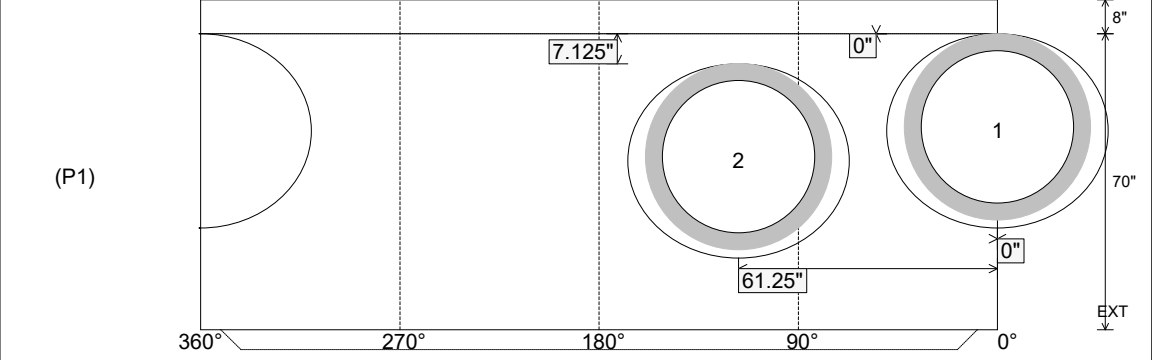

Coating (Int): Coating (Ext):	Seam Up: Tongue Seam Dn: n/a	Wall Thickness: 6" Floor Height: 8"	Height (Int): 70" Height (Ext): 78"	Weight (Net): 8180 lb Volume (Net): 2.09cu.yd
----------------------------------	---------------------------------	--	--	--