

Job Name: 26-1077 - Westside Markets of Greensboro Village  
 Job Location: Gallatin, TN  
 Contractor: Cleary Construction, Inc.

Plant: 100

Tech: J. Horsley - F

3/27/2026 4:34:55 PM

PC: C. Goff

**Structure ID: C4A**

**P2 MH048LD07S**

**MH FLAT TOP w/30"x36" Hole F/F**

- P3) 30" x 36" - CASTING HEIGHT - 6.50"
- P2) 48" - MH FLAT TOP w/30"x36" Hole F/F - 7"
- P1) 48" - MH BASE Custom Ht F/n - 29"
- 1) 48" - STORM INVERT CHANNEL - 1/4 HEIGHT
- 1) 48" - Conseal CS-102 1.00"
- 1) Hole - 24
- 3) Hole - 6
- 2) MH Step ML-10-TDS-NCR - 10"

0 lb  
 916 lb  
 3123 lb  
 1075 lb  
 0 lb  
 0 lb  
 0 lb  
 0 lb  
 -----  
 5114 lb

Structure Total:

Structure Notes:

1. PER ASTM C478 SPECIFICATIONS.
2. CONCRETE = 4,000 PSI AT 28 DAYS.
3. CASTING SUPPLIED BY OTHERS (JBS 2064 F/G/H - SINGLE CURB INLET).

REINFORCING PER ASTM A615 (GRADE 60).  
 - TOP SLAB (As .62) #5 BARS AT 6" C.C.E.W..  
 - RISER/WALLS (As .12)  
 - FLOOR (As .31) #5 BARS AT 12" C.C.E.W.

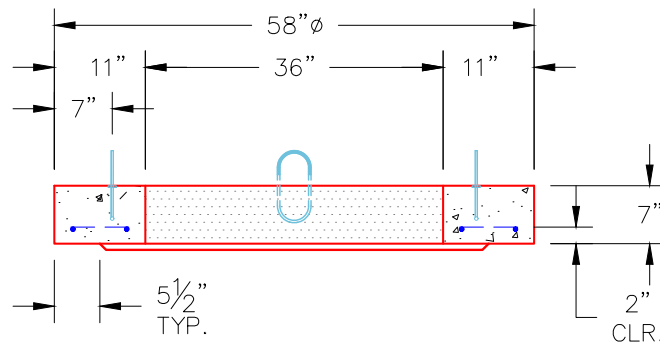
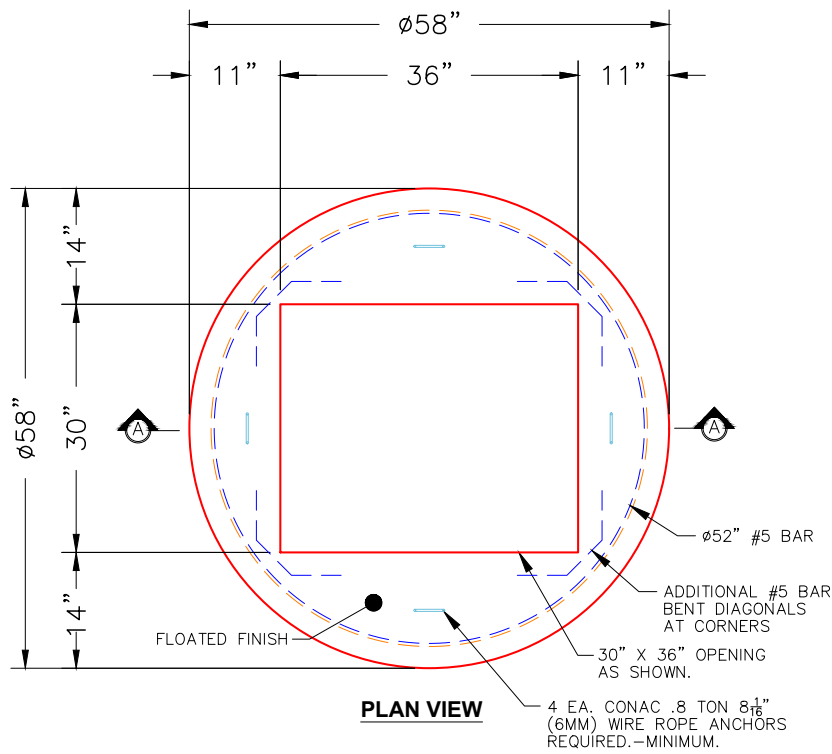

NOTES:

1. MANUFACTURED TO ASTM C-478 (LATEST REVISION).
2. CONCRETE: 4,000 PSI AT 28 DAYS.
3. REINFORCING: #5 BAR @ 6" O.C. E.W. (GRADE 60).

Coating (Int):  
 Coating (Ext):

Seam Up: Flat  
 Seam Dn: Flat

Wall Thickness: 5"

Height (Ext): 7"

Weight (Net): 916 lb  
 Volume (Net): 0.23cu.yd