

Job Name: 26-1077 - Westside Markets of Greensboro Village  
 Job Location: Gallatin, TN  
 Contractor: Cleary Construction, Inc.

Plant: 100  
 3/27/2026 4:33:48 PM

Tech: J. Horsley - F  
 PC: C. Goff



**Structure ID: C4A**

**P1 MH048BAVF**

**MH BASE Custom Ht F/n**

- P3) 30" x 36" - CASTING HEIGHT - 6.50"
- P2) 48" - MH FLAT TOP w/30"x36" Hole F/F - 7"
- P1) 48" - MH BASE Custom Ht F/n - 29"
- 1) 48" - STORM INVERT CHANNEL - 1/4 HEIGHT
- 1) 48" - Conseal CS-102 1.00"
- 1) Hole - 24
- 3) Hole - 6
- 2) MH Step ML-10-TDS-NCR - 10"

0 lb  
 916 lb  
 3123 lb  
 1075 lb  
 0 lb  
 0 lb  
 0 lb  
 0 lb  
 0 lb  
 Structure Total: 5114 lb

**Structure Notes:**  
 1. PER ASTM C478 SPECIFICATIONS.  
 2. CONCRETE = 4,000 PSI AT 28 DAYS.  
 3. CASTING SUPPLIED BY OTHERS (JBS 2064 F/G/H - SINGLE CURB INLET).  
  
 REINFORCING PER ASTM A615 (GRADE 60).  
 - TOP SLAB (As .62) #5 BARS AT 6" C.C.E.W..  
 - RISER/WALLS (As .12)  
 - FLOOR (As .31) #5 BARS AT 12" C.C.E.W.

Rim: 496.75' Rim to Invert: 3.5' Slack: 1.1" Sump: 1.6" Step Position: 45°

Position	Elev	Angle	Ext. (cw)	Pipe	Pipe OD	Connector	Hole	Horz Size	Up ( )	Offset
Invert 1	493.25'	0°	0"	18" HDPE	21.2"	Hole 24	24"	25.133"	0"	0"
Invert 2	494.67'	90°	45.5"	4" HDPE (perf pipe)	4.8"	Hole 6	6"	6.016"	18.25"	0"
Invert 3	494.67'	180°	91.125"	4" HDPE (perf pipe)	4.8"	Hole 6	6"	6.016"	18.25"	0"
Invert 4	494.67'	270°	136.625"	4" HDPE (perf pipe)	4.8"	Hole 6	6"	6.016"	18.25"	0"
Invert 5										
Invert 6										
Invert 7										
Invert 8										

RIGHT-SIDE UP VIEW (int. dimensions)

UPSIDE-DOWN VIEW (int. dimensions)

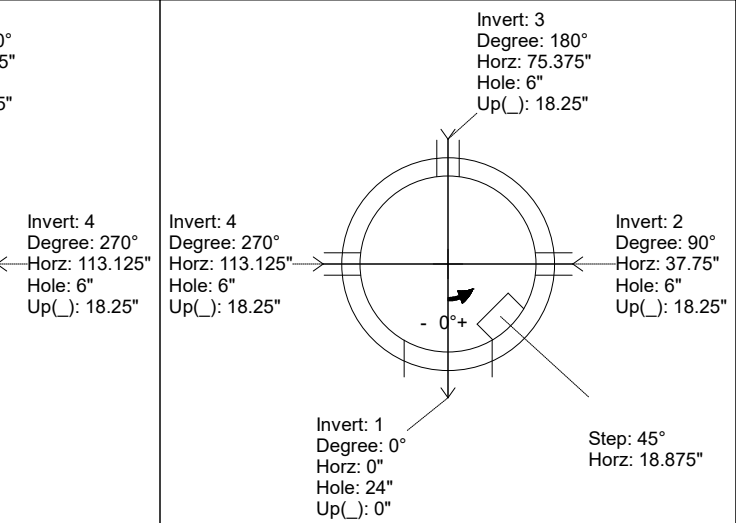
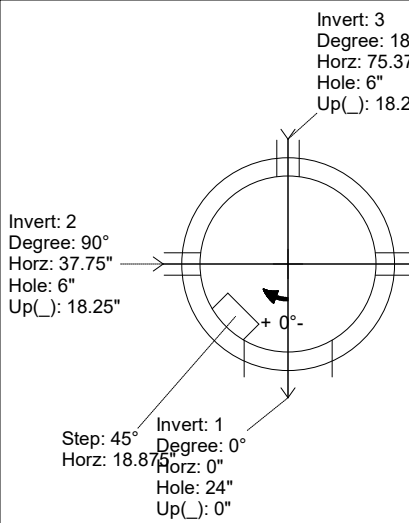
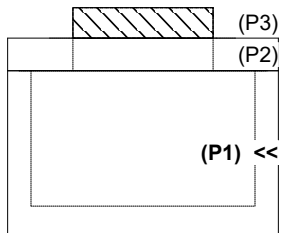

INSIDE WALL DIMENSIONS

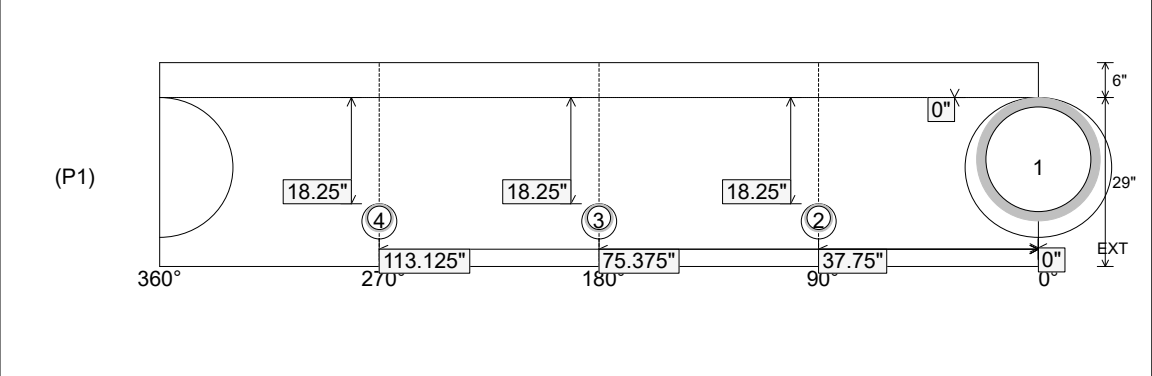

Coating (Int): Coating (Ext):	Seam Up: Flat Seam Dn: n/a	Wall Thickness: 5" Floor Height: 6"	Height (Int): 29" Height (Ext): 35"	Weight (Net): 3123 lb Volume (Net): 0.8cu.yd
----------------------------------	-------------------------------	--	--	---

Job Name: 26-1077 - Westside Markets of Greensboro Village  
 Job Location: Gallatin, TN  
 Contractor: Cleary Construction, Inc.

Plant: 100

3/27/2026 4:33:48 PM

Tech: J. Horsley - F

PC: C. Goff



**Structure ID: C4A**

**P1 MH048BAVF**

**MH BASE Custom Ht F/n**

P3) 30" x 36" - CASTING HEIGHT - 6.50"  
 P2) 48" - MH FLAT TOP w/30"x36" Hole F/F - 7"  
 P1) 48" - MH BASE Custom Ht F/n - 29"

1) 48" - STORM INVERT CHANNEL - 1/4 HEIGHT

- 1) 48" - Conseal CS-102 1.00"
- 1) Hole - 24
- 3) Hole - 6
- 2) MH Step ML-10-TDS-NCR - 10"

0 lb  
 916 lb  
 3123 lb  
 1075 lb  
 0 lb  
 0 lb  
 0 lb  
 0 lb  
 0 lb  
 Structure Total: 5114 lb

**Structure Notes:**

1. PER ASTM C478 SPECIFICATIONS.
2. CONCRETE = 4,000 PSI AT 28 DAYS.
3. CASTING SUPPLIED BY OTHERS (JBS 2064 F/G/H - SINGLE CURB INLET).

REINFORCING PER ASTM A615 (GRADE 60).  
 - TOP SLAB (As .62) #5 BARS AT 6" C.C.E.W..  
 - RISER/WALLS (As .12)  
 - FLOOR (As .31) #5 BARS AT 12" C.C.E.W.

Rim: 496.75' Rim to Invert: 3.5' Slack: 1.1" Sump: 1.6" Step Position: 45°

Position	Elev	Angle	Ext. (cw)	Pipe	Pipe OD	Connector	Hole	Horz Size	Up ( )	Offset
Invert 1	493.25'	0°	0"	18" HDPE	21.2"	Hole 24	24"	25.133"	0"	0"
Invert 2	494.67'	90°	45.5"	4" HDPE (perf pipe)	4.8"	Hole 6	6"	6.016"	18.25"	0"
Invert 3	494.67'	180°	91.125"	4" HDPE (perf pipe)	4.8"	Hole 6	6"	6.016"	18.25"	0"
Invert 4	494.67'	270°	136.625"	4" HDPE (perf pipe)	4.8"	Hole 6	6"	6.016"	18.25"	0"
Invert 5										
Invert 6										
Invert 7										
Invert 8										

RIGHT-SIDE UP VIEW (int. dimensions)

UPSIDE-DOWN VIEW (int. dimensions)

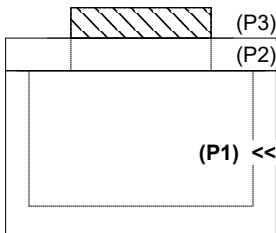
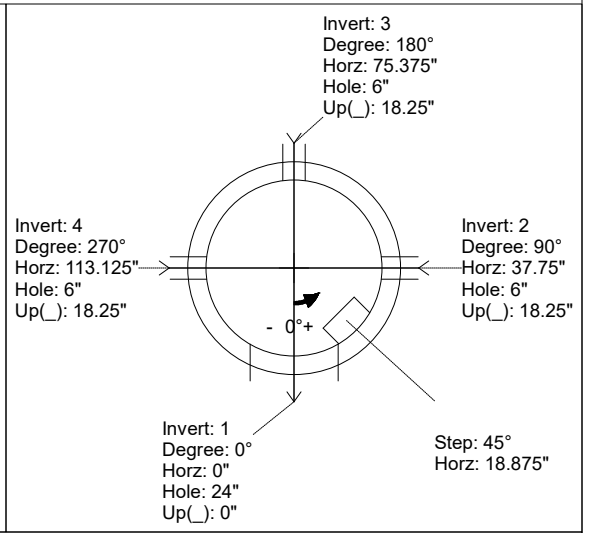
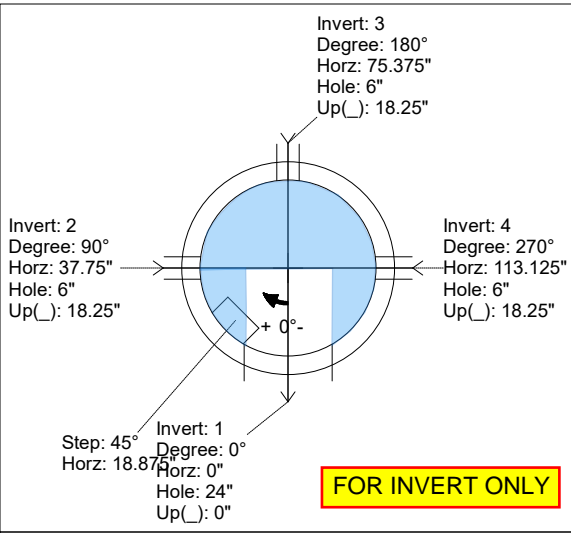

INSIDE WALL DIMENSIONS

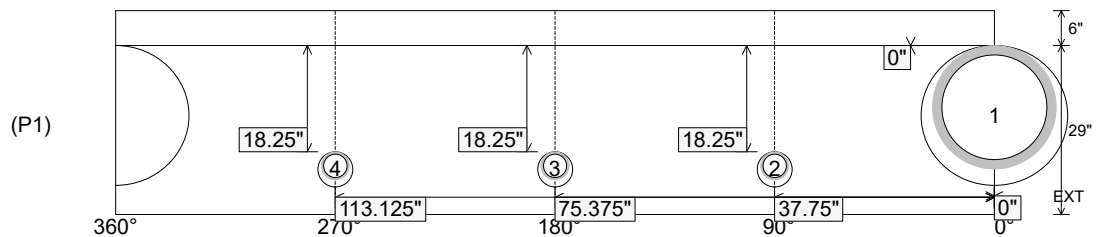

Coating (Int):  
 Coating (Ext):

Seam Up: Flat  
 Seam Dn: n/a

Wall Thickness: 5"  
 Floor Height: 6"

Height (Int): 29"  
 Height (Ext): 35"

Weight (Net): 3123 lb  
 Volume (Net): 0.8cu.yd