

Job Name: 26-1077 - Westside Markets of Greensboro Village
 Job Location: Gallatin, TN
 Contractor: Cleary Construction, Inc.

Plant: 100

3/30/2026 11:51:45 AM

Tech: J. Coppage - F

PC: C. Goff



Structure ID: C4

P1 MH048BA48

MH BASE T/n

- P3) 24" - CASTING HEIGHT - 7"
- P2) 48" - MH FLAT TOP w/ 24" ECC Hole F/G - 12"
- P1) 48" - MH BASE T/n - 48"
- 1) 48" - STORM INVERT CHANNEL - 1/4 HEIGHT
- 1) 48" - Conseal CS-102 1.00"
- 3) Hole - 24
- 3) Hole - 6
- 4) MH Step ML-10-TDS-NCR - 10"

0 lb
 1561 lb
 4056 lb
 1075 lb
 0 lb
 0 lb
 0 lb
 0 lb
 0 lb
 Structure Total: 6692 lb

Structure Notes:
 1. PER ASTM C478 SPECIFICATIONS.
 2. CONCRETE = 4,000 PSI AT 28 DAYS.
 3. CASTING SUPPLIED BY OTHERS (JBS 1150 F/C STORM).

REINFORCING PER ASTM A615 (GRADE 60).
 - TOP SLAB (As .62) #5 BARS AT 6" C.C.E.W..
 - RISER/WALLS (As .12)
 - FLOOR (As .31) #5 BARS AT 12" C.C.E.W.

Rim: 497.73' Rim to Invert: 5.51' Slack: 0.72" Sump: 1.6" Step Position: 270°

Position	Elev	Angle	Ext. (cw)	Pipe	Pipe OD	Connector	Hole	Horz Size	Up ()	Offset
Invert 1	492.22'	0°	0"	18" HDPE	21.2"	Hole 24	24"	25.133"	0"	0"
Invert 2	492.33'	108°	54.625"	18" HDPE	21.2"	Hole 24	24"	25.133"	1.375"	0"
Invert 3	493.85'	180°	91.125"	18" HDPE	21.2"	Hole 24	24"	25.133"	19.5"	0"
Invert 4	495.23'	60°	30.375"	4" HDPE (perf pipe)	4.8"	Hole 6	6"	6.016"	37.375"	0"
Invert 5	495.23'	225°	113.875"	4" HDPE (perf pipe)	4.8"	Hole 6	6"	6.016"	37.375"	0"
Invert 6	495.23'	315°	159.375"	4" HDPE (perf pipe)	4.8"	Hole 6	6"	6.016"	37.375"	0"
Invert 7										
Invert 8										

RIGHT-SIDE UP VIEW (int. dimensions)

UPSIDE-DOWN VIEW (int. dimensions)

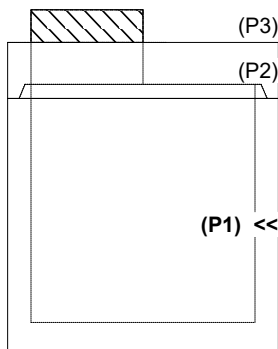
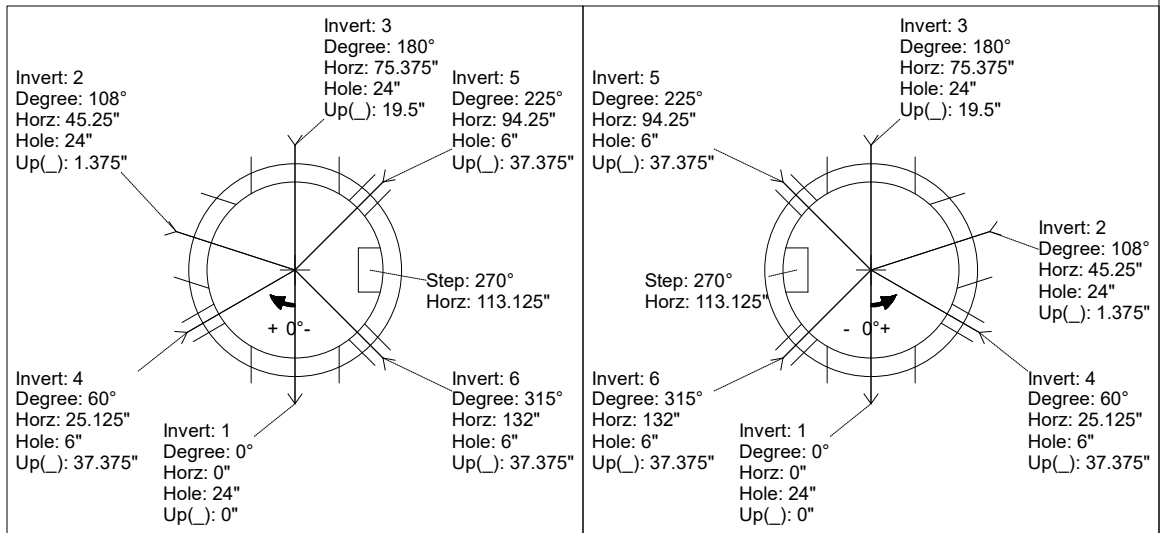

INSIDE WALL DIMENSIONS

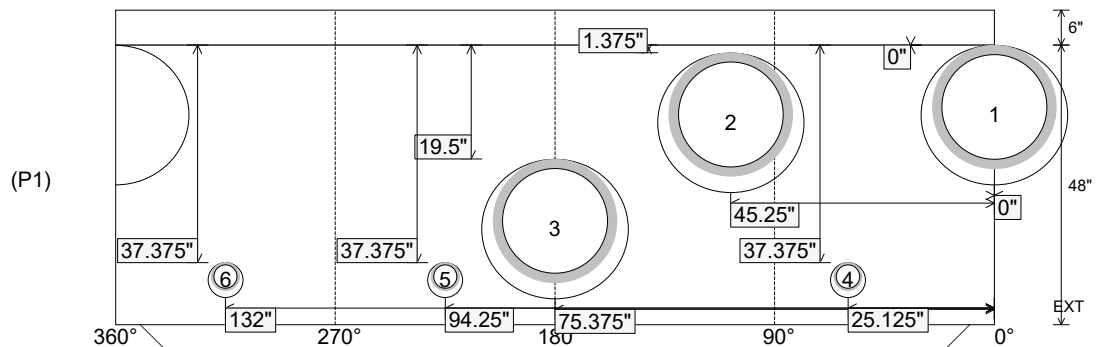

Coating (Int):
 Coating (Ext):

Seam Up: Tongue
 Seam Dn: n/a

Wall Thickness: 5"
 Floor Height: 6"

Height (Int): 48"
 Height (Ext): 54"

Weight (Net): 4056 lb
 Volume (Net): 1.04cu.yd

Job Name: 26-1077 - Westside Markets of Greensboro Village
 Job Location: Gallatin, TN
 Contractor: Cleary Construction, Inc.

Plant: 100
 3/30/2026 11:51:45 AM

Tech: J. Coppage - F
 PC: C. Goff



Structure ID: C4

P1 MH048BA48

MH BASE T/n

- P3) 24" - CASTING HEIGHT - 7"
- P2) 48" - MH FLAT TOP w/ 24" ECC Hole F/G - 12"
- P1) 48" - MH BASE T/n - 48"
- 1) 48" - STORM INVERT CHANNEL - 1/4 HEIGHT**
- 1) 48" - Conseal CS-102 1.00"
- 3) Hole - 24
- 3) Hole - 6
- 4) MH Step ML-10-TDS-NCR - 10"

Structure Notes:
 1. PER ASTM C478 SPECIFICATIONS.
 2. CONCRETE = 4,000 PSI AT 28 DAYS.
 3. CASTING SUPPLIED BY OTHERS (JBS 1150 F/C STORM).

 REINFORCING PER ASTM A615 (GRADE 60).
 - TOP SLAB (As .62) #5 BARS AT 6" C.C.E.W..
 - RISER/WALLS (As .12)
 - FLOOR (As .31) #5 BARS AT 12" C.C.E.W.

0 lb
 1561 lb
 4056 lb
 1075 lb
 0 lb
 0 lb
 0 lb
 0 lb
 0 lb
 Structure Total: 6692 lb

Rim: 497.73' Rim to Invert: 5.51' Slack: 0.72" Sump: 1.6" Step Position: 270°

Position	Elev	Angle	Ext. (cw)	Pipe	Pipe OD	Connector	Hole	Horz Size	Up ()	Offset
Invert 1	492.22'	0°	0"	18" HDPE	21.2"	Hole 24	24"	25.133"	0"	0"
Invert 2	492.33'	108°	54.625"	18" HDPE	21.2"	Hole 24	24"	25.133"	1.375"	0"
Invert 3	493.85'	180°	91.125"	18" HDPE	21.2"	Hole 24	24"	25.133"	19.5"	0"
Invert 4	495.23'	60°	30.375"	4" HDPE (perf pipe)	4.8"	Hole 6	6"	6.016"	37.375"	0"
Invert 5	495.23'	225°	113.875"	4" HDPE (perf pipe)	4.8"	Hole 6	6"	6.016"	37.375"	0"
Invert 6	495.23'	315°	159.375"	4" HDPE (perf pipe)	4.8"	Hole 6	6"	6.016"	37.375"	0"
Invert 7										
Invert 8										

RIGHT-SIDE UP VIEW (int. dimensions)

UPSIDE-DOWN VIEW (int. dimensions)

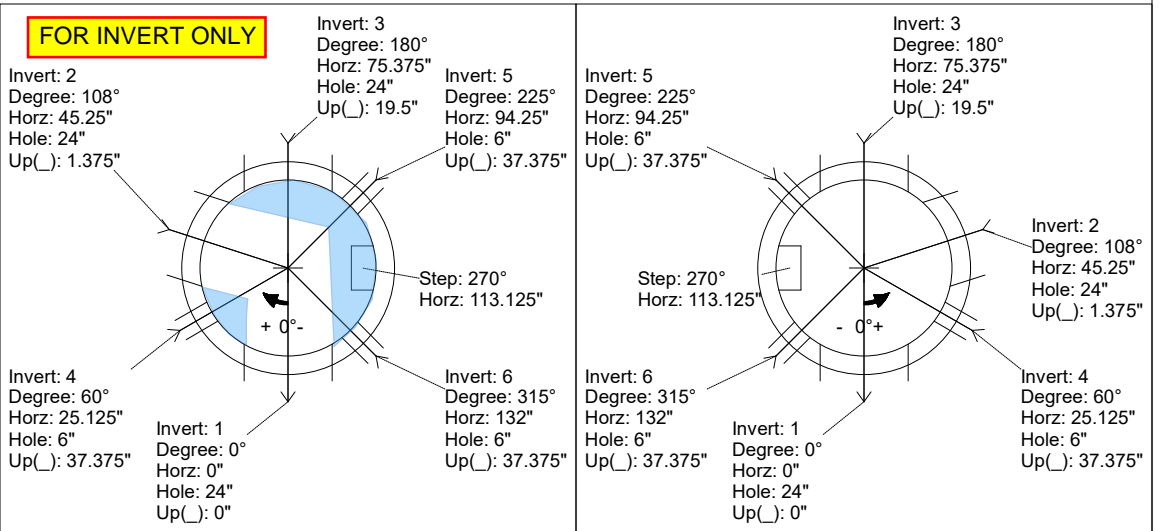

INSIDE WALL DIMENSIONS

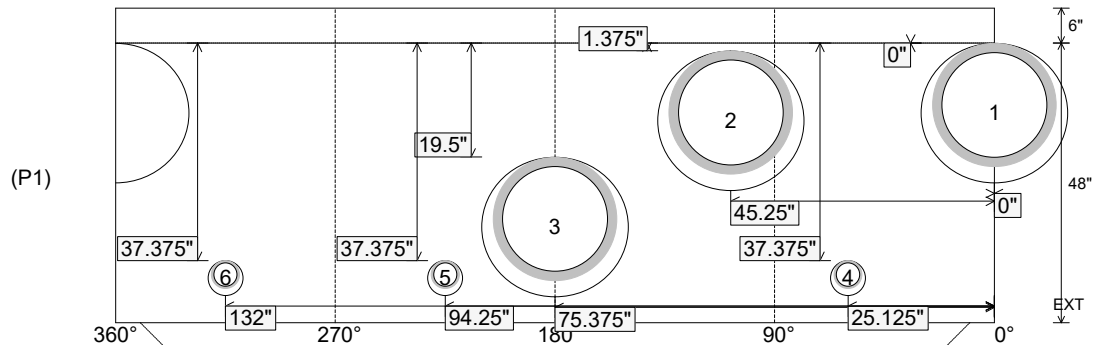

Coating (Int):
 Coating (Ext):

Seam Up: Tongue
 Seam Dn: n/a

Wall Thickness: 5"
 Floor Height: 6"

Height (Int): 48"
 Height (Ext): 54"

Weight (Net): 4056 lb
 Volume (Net): 1.04cu.yd