

Job Name: 26-1077 - Westside Markets of Greensboro Village
Job Location: Gallatin, TN
Contractor: Cleary Construction, Inc.

PC: C. Goff
 TECH: J. Coppage - F
 Plant: 100



Structure ID: C2
 Spec: Storm
 Type: STM.MH
 Size: 48"

Rim: 496.65'
 Invert: 490.67'
 Rim to Invert: 5.98'

Sump: 1.9"
 Floor (Top): 490.512'
 Floor Height: 6"

Floor (Bot): 490.012'
 Overall Height: 6.542'
 Slack: 1.16"

Structure Notes:
 1. PER ASTM C478 SPECIFICATIONS.
 2. CONCRETE = 4,000 PSI AT 28 DAYS.
 3. CASTING SUPPLIED BY OTHERS (JBS 2064 F/G/H - SINGLE CURB INLET).
 REINFORCING PER ASTM A615 (GRADE 60).
 - TOP SLAB (As .62) #5 BARS AT 6" C.C.E.W..
 - RISER/WALLS (As .12)
 - FLOOR (As .31) #5 BARS AT 12" C.C.E.W.

STRUCTURE SUMMARY:

P3) 30" x 36" - CASTING HEIGHT - 6.50"	0 lb
P2) 48" - MH FLAT TOP w/30"x36" Hole - 12"	1171 lb
P1) 48" - MH BASE - 54"	4435 lb
1) 48" - STORM INVERT CHANNEL - 1/4 HEIGHT	1075 lb
1) 48" - Conseal CS-102 1.00"	0 lb
2) Hole - 30	0 lb
3) Hole - 6	0 lb
4) MH Step ML-10-TDS-NCR - 10"	0 lb
Structure Total:	6681 lb

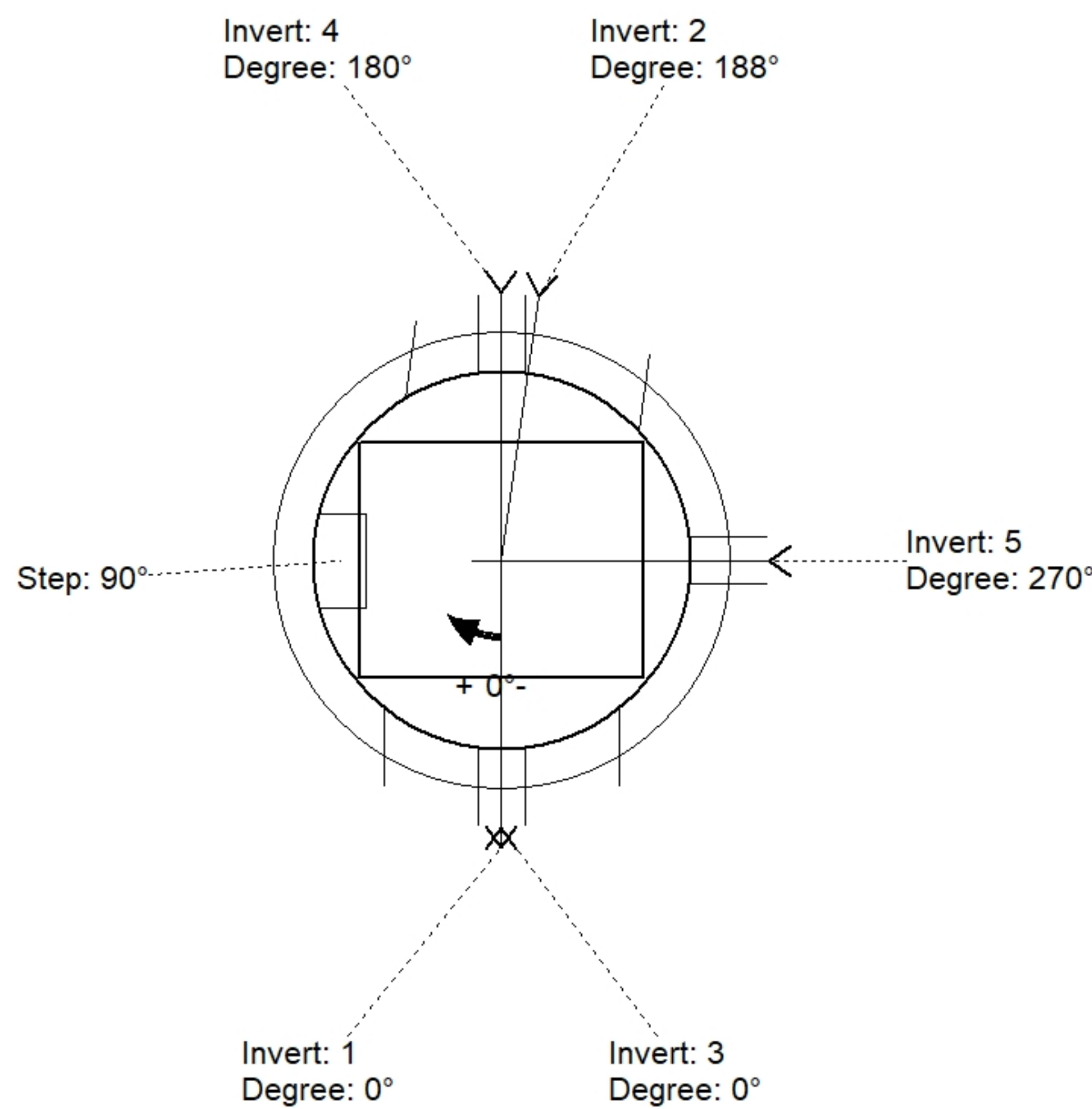

Position	Elev	Angle	Pipe	Pipe OD	Hole	Connector	Up ()	Ref
Rim	496.65'							
Reducer								
Invert 1	490.67'	0°	24" HDPE	27.8"	30"	Hole 30	0"	P1
Invert 2	490.72'	188°	24" HDPE	27.8"	30"	Hole 30	0.6"	P1
Invert 3	494.15'	0°	4" HDPE (perf pipe)	4.8"	6"	Hole 6	43.26"	P1
Invert 4	494.15'	180°	4" HDPE (perf pipe)	4.8"	6"	Hole 6	43.26"	P1
Invert 5	494.15'	270°	4" HDPE (perf pipe)	4.8"	6"	Hole 6	43.26"	P1
Invert 6								
Invert 7								
Invert 8								

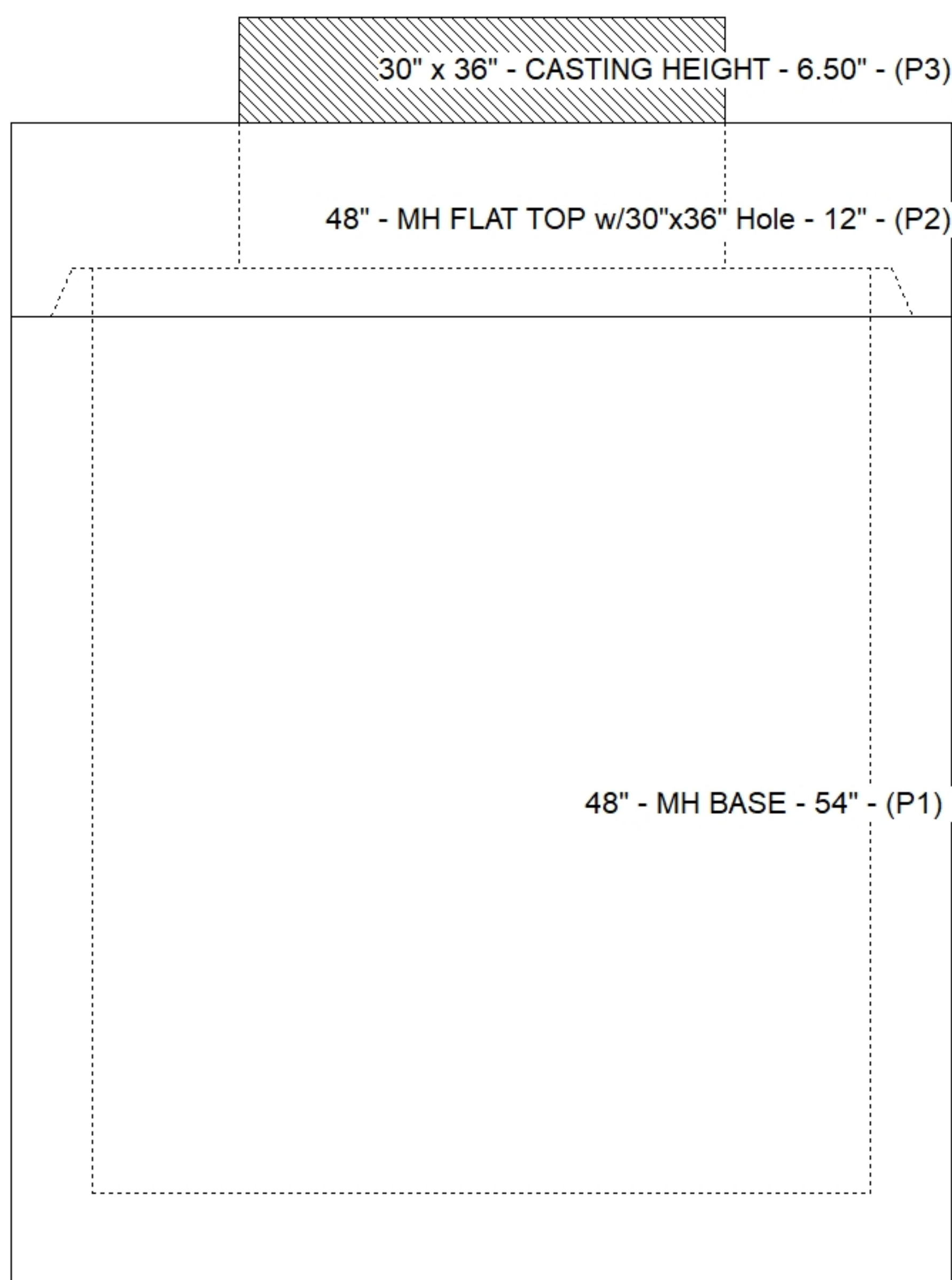

Default - Interior Dimensions

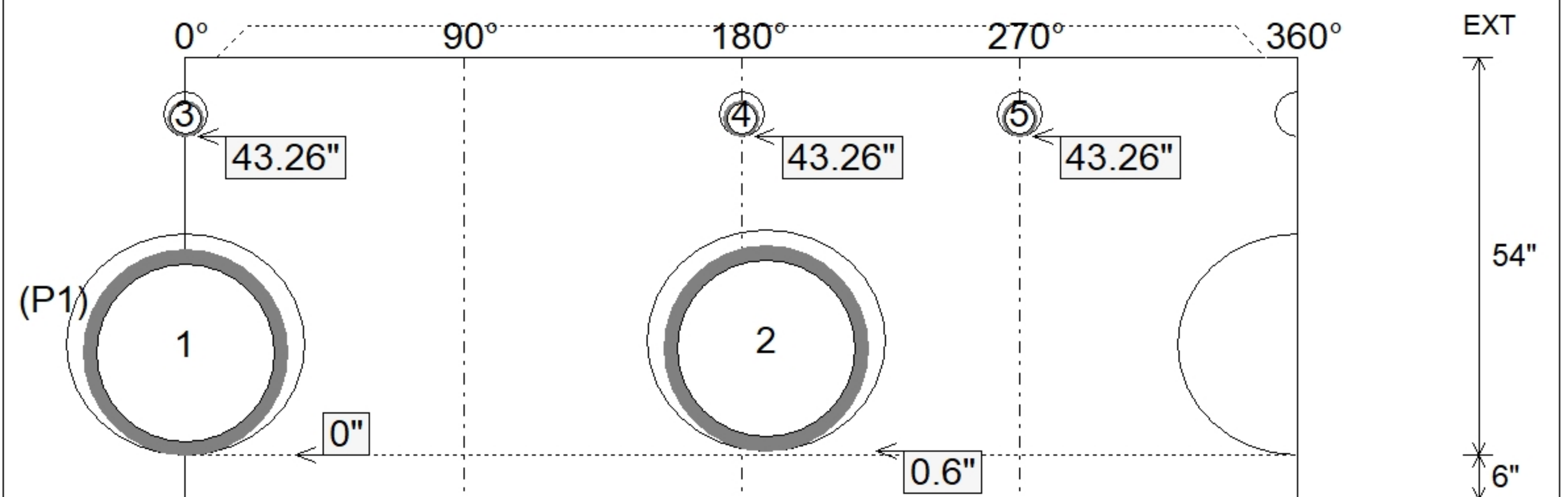

Submittal Drawing
 4/2/2026 3:00:07 PM

SUBMITTAL
 APPROVED BY: